

ANGLE OPERATORS OF COMMUTING SQUARE SUBFACTORS

By

Michael Ray Montgomery

Dissertation

Submitted to the Faculty of the
Graduate School of Vanderbilt University
in partial fulfillment of the requirements
for the degree of

DOCTOR OF PHILOSOPHY

in

Mathematics

June 30, 2022

Nashville, Tennessee

Approved:

Dietmar Bisch, Ph.D.

Jesse Peterson, Ph.D.

Spencer Dowdall, Ph.D.

Marcelo Disconzi, Ph.D.

Thomas Kephart, Ph.D.

ACKNOWLEDGMENTS

First, I sincerely thank my advisor, Dietmar Bisch, for suggesting this problem and his guidance both academically and professionally. I am grateful for the countless hours discussing research and his patience throughout this project.

I am thankful to my family, my wife Sydney, my parents Tim and Cheri, and my brother Brad for their love and support.

Finally, I am grateful to the faculty, staff, and fellow graduate students of the Math Department for the many things they have taught me and the friendships created.

TABLE OF CONTENTS

	Page
LIST OF FIGURES	v
1 Introduction	1
2 Preliminaries	3
2.1 Inclusions of Finite Dimensional C*-Algebras	3
2.2 Commuting Squares	5
2.3 Construction of Subfactors	7
3 Planar Algebras	10
3.1 Hadamard matrices and the Spin Model	17
3.2 The Angle Operator and Flat Elements	21
3.3 A Tunnel Construction for the Spin Model	30
4 Symmetric Enveloping Algebras	34
4.1 Computation of $\tau(\Theta_u^n)$	37
4.2 Infinite depth spin model subfactors	42
5 Generalizations to Commuting Squares	51
5.1 The Colored Graph Planar Algebra	51
5.2 Operators in $C^*(M, e_N, JMJ)$	66
5.3 A Representation of the Fusion Algebra	67
5.4 Computation of τ	69
5.5 Summary and Remarks	75
References	78

A	Code for Petrescu's complex Hadamards	81
----------	--	-----------

LIST OF FIGURES

Figure		Page
1.1	A_∞ Principal Graph	1
3.1	Vanilla Planar Tangle.	11
3.2	Shaded Planar Tangle	12
5.1	Colored Planar Tangle	51

CHAPTER 1

Introduction

Jones defined an index $[M : N]$ for an inclusion of II_1 factors $N \subset M$ in [Jon83]. He proved that $[M : N] \in \{4 \cos^2(\frac{\pi}{n}) | n \geq 3\} \cup [4, \infty]$ by introducing the basic construction of a finite index subfactor, $N \subset M$, in [Jon83]. Iterating his construction yields the Jones tower of II_1 factors

$$M_{-1} = N \subset M_0 = M \subset M_1 \subset M_2 \subset \dots .$$

Taking relative commutants of these factors, we may build the standard invariant of the subfactor which consists of finite dimensional C^* -algebras, $\{M'_i \cap M_n | i = -1, 0, n = -1, 0, 1, \dots\}$, inclusions $M'_0 \cap M_n \subset M'_{-1} \cap M_n$, $M'_i \cap M_n \subset M'_i \cap M_{n+1}$, and Jones projections $\{e_n | n \geq 1\}$. Classifying standard invariants and constructing exotic examples has been a multi-decade project that has contributed to low-dimensional topology and many areas of mathematical physics. A summary of this can be found in [JMS14] and [AMP], and for an introduction to subfactors see [GHJ89] and [JS97]. Popa axiomatized standard invariants using λ -lattices in [Pop95]. Jones used λ -lattices to axiomatize the standard invariants of extremal subfactors as subfactor planar algebras in [Jon21]. Weaker invariants of $N \subset M$ can be constructed from the Bratteli diagrams of the standard invariant, called the principal graphs of $N \subset M$.

The possible standard invariants of the hyperfinite II_1 factor remains an important open question. For a finite index subfactor $N \subset M$, the Jones projections generate the Temperley-Lieb standard invariant with loop parameter $\delta = \sqrt{[M : N]}$, $TL(\delta)$. The Temperley-Lieb standard invariant is minimal as all standard invariants with Jones index δ^2 contain $TL(\delta)$. Subfactors, $N \subset M$, with Jones index $[M : N] \geq 4$ and Temperley-Lieb standard invariants have A_∞ principal graphs. It is an open problem to determine which



Figure 1.1: A_∞ Principal Graph

subfactors of the hyperfinite II_1 factor have Temperley-Lieb standard invariants. It is also not known at which indices greater than four these can occur.

In chapter 2 we outline fundamental results for subfactors and finite dimensional commuting squares. Much of this background can be found in [JS97] or [GHJ89].

Subfactors generated from complex Hadamard matrices are called spin model subfactors. The principal graphs of subfactors for twisted tensor products of Fourier matrices have been identified by Burstein as Bisch-Haagerup subfactors, but very little is known about the standard invariants of spin model subfactors outside of this family (see [Bur15] and [BH96]). In [Jon21] and [Jon19], Jones develops the planar algebra formalism that axiomatizes standard invariants. Planar algebras became a powerful computational tool to classify small index standard invariants and is a central tool for this dissertation. Jones extended the planar algebra formalism for spin planar algebras, P^{Spin} , to include string crossings with complex Hadamard matrices. This led Jones to define an angle operator, Θ_u , in the sense of [SW94], whose 1-eigenspace is the standard invariant of the subfactor. In chapter 3 we present Jones's work on angle operators and modify his formalism to build tunnel constructions of spin models.

In chapter 4 we identify this angle operator as an element of $C^*(M, e_N, JMJ)$, the C^* -algebra generated by M , e_N , and JMJ on $L^2(M)$. Popa showed in [Pop99] that $C^*(M, e_N, JMJ)$ admits a tracial state, τ , which is faithful iff the subfactor is amenable and M is hyperfinite. We then compute $\tau(\Theta_u^n)$ in terms of the standard invariant and prove a correspondence between the principal graph spectrum and angle operator spectrum. Since the angle operator has finite dimensional representations we can compute elements of its spectrum. We also find non-algebraic integers in the spectra of angle operators for Petrescu's continuous family of 7×7 complex Hadamard matrices [Pet97] and Paley type II Hadamard matrices [Pal33]. Since the spectrum of finite graphs only contains algebraic integers, these subfactors are infinite depth.

Finally, in chapter 5, we generalize these results to symmetric commuting squares. We show that the planar algebra of flat elements coincides with the subfactor planar algebra and we build a faithful representation of the fusion algebra inside the symmetric enveloping algebra. For sake of exposition and since a new planar algebra must be defined, this chapter is set apart from chapters 3 and 4 whose computations take place in P^{Spin} .

CHAPTER 2

Preliminaries

The following section serves two purposes. Commuting squares, which we define shortly, are an important tool for constructing inclusions of finite von Neumann algebras but they also arise naturally in the standard invariant of a subfactor. First, we will consider inclusions of finite dimensional algebras. A detailed approach to inclusions of finite dimensional C^* algebras and commuting squares can be found in [GHJ89] or [JS97].

2.1 Inclusions of Finite Dimensional C^* -Algebras

Since finite dimensional C^* -algebras admit a system of matrix units, they can be identified with multi-matrix algebras, $\bigoplus_{i=1}^k M_{n_i}(\mathbb{C})$, where $v = (n_i)_{i=1}^k$ is called the dimension vector. This also shows that traces on finite dimensional C^* -algebras are determined by a trace vector $(t_i)_{i=1}^k$ which yield the trace of a minimal projection for each factor. Let $V(A)$ denote the set of minimal central projections. Due to Bratteli, the inclusion of two finite dimensional C^* -algebras $A \subset B$ is determined up to an inner automorphism by a bipartite graph Γ . This graph has the vertex set $V(A) \sqcup V(B)$ and $\sqrt{\dim(pqA'pq \cap pqBpq)}$ edges between $p \in V(A)$ and $q \in V(B)$. This graph is called the Bratteli diagram, and we will also use Γ to denote its adjacency matrix which we will refer to as the inclusion matrix. We will call an inclusion connected if its Bratteli diagram is connected. If this is a unital inclusion then $\Gamma v_A = v_B$, where we think of Γ as a " $V(B) \times V(A$)"-matrix.

Bratteli diagrams provide a natural representation of a tower of algebras called the path algebra construction (see [GHJ89]). Let $\mathbb{C} \subset A_1 \subset A_2 \subset \dots \subset A_k$ be a sequence of unital inclusions with Bratteli diagrams Γ_i for $A_i \subset A_{i+1}$. A path in the tower of Bratteli diagrams is a sequence of edges $(e_i)_{i=0}^k, e_i \in \Gamma_i$ such that e_i and e_{i+1} share a vertex in $V(A_{i+1})$. Let H be the space of formal linear combinations of paths. Then we can construct a system of matrix units $\{f_{\alpha,\beta} \mid \alpha, \beta \text{ paths sharing a vertex in } V(A_k)\}$ where $f_{\alpha,\beta}(\gamma) = \delta_{\beta=\gamma}\alpha$. It can be shown that this algebra is A_k . Furthermore, we can use $f_{\alpha,\beta}$'s to generate matrix units for each A_i ,

$$\left\{ \sum_{\substack{\alpha' \text{ a path} \\ \text{in } A_i \subset A_k}} f_{\alpha \circ \alpha', \beta \circ \alpha'} \mid \alpha, \beta \text{ paths in } \mathbb{C} \subset A_i \text{ ending at the same vertex in } V(A_i) \right\}$$

where $\alpha \circ \alpha'$ denotes concatenation of paths when they share a vertex in $V(A_i)$. We will use (\circ) to denote concatenation of paths and some restrictions on sums will be implied by this operation. It will also be

convenient to let $\Omega(A_i, A_{i+1}, \dots, A_j)$ denote the set of paths in the sequence of Bratteli diagrams for these inclusions.

Remark 2.1.1. *This representation of A_k can be decomposed into irreducible representations by fixing a vertex of $V(A_k)$ and considering the subspace generated by paths ending at that vertex. This implies the path algebra representation contains each irreducible representation of A_k exactly once.*

Similar to subfactors, we have a basic construction for inclusions of finite dimensional C*-algebras (see [Jon83]).

Lemma 2.1.2. *Let $A \subset B$ be an inclusion of finite dimensional C*-algebras with a faithful trace tr on B , from a trace vector \vec{t}_B , $e \in B(L^2(B, tr))$ the orthogonal projection from B onto A , E_A the conditional expectation onto A , and let J be the conjugate linear isometry given by $J(\hat{x}) = \hat{x}^*$ where $\hat{x} \in \hat{B} \subset L^2(B, tr)$. Then we have a basic construction $B_1 = \langle B, e \rangle$ and:*

- (i) $ze = Jz^*Je$ for all $z \in Z(A)$.
- (ii) For $b \in B$, $b \in Z(B)$ iff $b = Jb^*J$.
- (iii) The map, $z \mapsto Jz^*J$, from $Z(A)$ to $Z(B_1)$ is a *-isomorphism.
- (iv) If Γ is the inclusion matrix for $A \subset B$, then Γ^t is the inclusion matrix for $B \subset B_1$ using the identification from (iii).
- (v) $B_1 = \text{span}(BeB)$.

Proposition 2.1.3. *Let $A \subset B$ be a connected inclusion of multi-matrix algebras with inclusion matrix Γ with a tracial state tr_B coming from the trace vector \vec{t}_B . Then the following are equivalent:*

- (i) tr_B extends to a tracial state on B_1 and $E_B(e) = \lambda \cdot 1$ for some $\lambda \in \mathbb{C}$ (i.e. tr_B is a Markov trace of modulus λ^{-1}).
- (ii) $\Gamma^t \Gamma \vec{t}_B = \lambda^{-1} \vec{t}_B$.

Furthermore, \vec{t}_B must be the Perron-Frobenius vector for $\Gamma^t \Gamma$, which is unique up to a scalar, and is the eigenvector to the eigenvalue $\lambda^{-1} = \|\Gamma\|^2$.

In [PP86], Pimsner and Popa generalize the notion of index to conditional expectations of von Neumann algebras. They compute $Ind(E_N^M)$ for $N = \bigoplus_{k \in K} M_{n_k}(\mathbb{C})$ and $M = \bigoplus_{l \in L} M_{m_l}(\mathbb{C})$ multi-matrix algebras,

inclusion matrix $\Gamma = (\gamma_{k,l})_{k \in K, l \in L}$, and trace vectors $\vec{t} = (t_l)_{l \in L}$ and $\vec{s} = (s_k)_{k \in K}$, where E_N^M denotes the trace preserving conditional expectation from M onto N .

Theorem 2.1.4. [PP86] $Ind(E_N^M) = \max_l \left\{ \sum_k \frac{b_{k,l} s_k}{t_l} \right\}$ where $b_{k,l} = \min\{\gamma_{k,l}, n_k\}$.

2.2 Commuting Squares

We now consider a square of multi-matrix algebras with compatible traces. These are important objects used to build subfactors, but we must impose additional conditions to ensure they yield subfactors and an easily computable Jones index.

Definition 2.2.1. Let $A_{i,j}$ for $i, j = 0, 1$ be multi-matrix algebras with the unital inclusions

$$A_{1,0} \subset A_{1,1}$$

$\cup \quad \cup$ and normalized faithful traces $tr_{i,j}$ that agree with these inclusions. Each pair of these

$$A_{0,0} \subset A_{0,1}$$

algebras has a unique trace preserving conditional expectation that we will denote by E . This is a **commuting**

square if
$$\begin{array}{ccc} A_{1,0} & \xrightarrow{i} & A_{1,1} \\ E \downarrow & & \downarrow E \\ A_{0,0} & \xrightarrow{i} & A_{0,1} \end{array}$$
 commutes, i.e. $E_{A_{1,0}}^{A_{1,1}} E_{A_{0,1}}^{A_{0,0}} = E_{A_{0,0}}^{A_{0,1}}$.

Proposition 2.2.2. The square above is commuting iff

(i) $A_{0,0} = A_{1,0} \cap A_{0,1}$.

(ii) $A_{0,1} \cap A_{0,0}^\perp$ is perpendicular to $A_{1,0} \cap A_{0,0}^\perp$ with respect to $tr_{1,1}$.

Proof. Starting with a commuting square, (i) is immediate. Since each map fixes $A_{0,0}$ we can pass to

$$\begin{array}{ccc} A_{1,0} \cap A_{0,0}^\perp & \xrightarrow{i} & A_{1,1} \cap A_{0,0}^\perp \\ E \downarrow & & \downarrow E \\ 0 & \xrightarrow{i} & A_{0,1} \cap A_{0,0}^\perp \end{array}$$

the quotient by $A_{0,0}$ to obtain . Since E is an orthogonal projection, this

implies (ii).

Starting with conditions (i) and (ii) it is clearly a commuting square. □

Example 2.2.3. Each square of algebras in the standard invariant of a subfactor $N \subset M$ is a commuting square with traces induced by M_k .

Proof. By the proposition above, interchanging $A_{0,1}$ and $A_{1,0}$ yields a commuting square and so by our definition the roles of inclusions and conditional expectations can also be interchanged. Thus it suffices to

show that $E_{N' \cap M_k}(x) = E_{M' \cap M_k}(x)$ for $x \in M' \cap M_{k+1}$. Letting $m \in M$, $mx = xm$ and by applying E_{M_k} , $mE_{M_k}(x) = E_{M_k}(x)m$ which implies $E_{M' \cap M_k}(x) = E_{M_k}(x)$ and likewise for N . \square

Definition 2.2.4. A square of algebras $A_{i,j}$ with connected inclusions is called a **symmetric or non-degenerate commuting square** if $A_{1,1} = \text{span}A_{0,1}A_{1,0} = \text{span}A_{1,0}A_{0,1}$.

Proposition 2.2.5. Consider the following commuting square with all four inclusions connected and their respective inclusion matrices.

$$\begin{array}{ccc} A_{1,0} & \overset{H}{\subset} & A_{1,1} \\ \kappa \cup & & \cup L \\ A_{0,0} & \overset{G}{\subset} & A_{0,1} \end{array}$$

Let e be the Jones projection for $A_{1,0} \subset A_{1,1}$. Then the following conditions are equivalent:

- (i) This square is symmetric.
- (ii) $G^t K = LH^t$.
- (iii) $\bigvee \{ueu^* | u \in \mathcal{U}(A_{0,1})\} = 1$ on $L^2(A_{1,1})$.

Furthermore, the Markov trace for $A_{1,0} \subset A_{1,1}$ is the Markov trace for every other inclusion in the square.

This proposition allows us to perform the basic construction on a square of algebras. Let e be the Jones projection for $A_{1,0} \subset A_{1,1}$. Setting $A_{1,2} = \langle A_{1,1}, e \rangle$ and $A_{0,2} = \{A_{0,1}, e\}''$, we can extend our commuting square, however, by (iii), $A_{0,2}$ is isomorphic to the basic construction of $A_{0,0} \subset A_{0,1}$ if and only if the original square is symmetric.

Observe that a square of algebras provides two different path algebra representations coming from $\mathbb{C} \subset A_{0,0} \subset A_{1,0} \subset A_{1,1}$ and $\mathbb{C} \subset A_{0,0} \subset A_{0,1} \subset A_{1,1}$. Let Ω and Π respectively be the sets of paths in these inclusions, H_Ω and H_Π their linear spans, and $\{p_{\alpha,\alpha'}\}, \{q_{\beta,\beta'}\}$ the corresponding matrix units. The following proposition rephrases commuting and symmetric squares in terms of the path algebra representation.

Proposition 2.2.6. (Biunitary Condition [JS97]) Let $A_{i,j}$ be a square of algebras with the notation above for the two path algebra representations. Then there is a $\Omega(A_{0,0}, A_{1,0}, A_{1,1}) \times \Omega(A_{0,0}, A_{0,1}, A_{1,1})$ matrix $U = (u_{\alpha,\beta})_{\alpha,\beta}$ with complex coefficients such that

- (i) $u_{\alpha,\beta} = 0$ unless α and β share a vertex in $V(A_{0,0})$ and $V(A_{1,1})$.
- (ii) $U: H_\Pi \rightarrow H_\Omega$ by $U(\beta) = \sum_\alpha u_{\alpha,\beta_1 \circ \beta_2} \beta_0 \circ \alpha$ is a unitary, where $\beta = \beta_0 \circ \beta_1 \circ \beta_2$.

(iii) $p_{\alpha, \alpha'} = \sum_{\beta, \beta'} u_{\alpha_1 \circ \alpha_2, \beta} q_{\alpha_0 \circ \beta, \alpha'_0 \circ \beta'} \overline{u_{\alpha'_1 \circ \alpha'_2, \beta'}}$ where $\alpha = \alpha_0 \circ \alpha_1 \circ \alpha_2$ and $\alpha' = \alpha'_0 \circ \alpha'_1 \circ \alpha'_2$.

Then we have the following:

(a) If U' satisfies (i) – (iii) then $U'U^* \in \mathcal{U}(Z(A_{1,1}))$.

(b) If tr is a faithful tracial state on $A_{1,1}$, let $t_{\alpha}^{i,j}$ be the component of the trace vector for $A_{i,j}$ corresponding to the vertex that α and $V(A_{i,j})$ share. Let V be a $\Omega(A_{0,1}, A_{1,1}) \circ \Omega(A_{1,0}, A_{1,1}) \times \Omega(A_{0,0}, A_{0,1}) \circ \Omega(A_{0,0}, A_{1,0})$ matrix defined by

$$v_{\beta_2 \circ \alpha_2, \beta_1 \circ \alpha_1} = \begin{cases} \sqrt{\frac{t_{\beta_1}^{0,0} t_{\alpha_2}^{1,1}}{t_{\beta_1}^{0,1} t_{\alpha_1}^{1,0}}} \overline{u_{\alpha_1 \circ \alpha_2, \beta_1 \circ \beta_2}} & \text{if all concatenations are well-defined.} \\ 0 & \text{otherwise.} \end{cases}$$

Then V is an isometry iff $A_{i,j}$ is commuting and a unitary iff $A_{i,j}$ is symmetric. When V is a unitary we will refer to the pair U, V as a biunitary.

Remark 2.2.7. To be able to iterate the basic construction we must use the Markov trace. Then U completely characterizes a square of algebras and when the square of algebras is symmetric with respect to the Markov

$$\begin{array}{ccc} A_{1,1} & \subset & A_{1,2} \\ \text{trace, } V \text{ is the unitary characterizing the basic construction of the square} & \cup & \cup \\ A_{0,1} & \subset & A_{0,2} \end{array}$$

2.3 Construction of Subfactors

Let $A_{i,j}$, $i, j = 0, 1$ be a square of multi-matrix algebras with $A_{1,0} \subset A_{1,1}$ connected with the Markov trace on $A_{1,1}$. We can iteratively perform the basic construction and define $A_{1,k} = \langle A_{1,k-1}, e_{A_{1,k-2}} \rangle$ and $A_{0,k} = \{A_{0,k-1}, e_{A_{1,k-2}}\}''$. If we choose the unique Markov trace for $A_{1,0} \subset A_{1,1}$, then proposition 2.1.3 implies this trace extends to a faithful unital trace τ on $\bigcup_k A_{1,k}$. Since the C^* -algebra norm is unique, for $a \in A_{1,k}$, $b \in A_{1,m}$ and $m > k$, then $\|ab\|_{2,\tau} \leq \|a\| \cdot \|b\|_{2,\tau}$. Setting $H_{\tau} = \overline{\bigcup_k A_{1,k}}^{\langle, \rangle_{\tau}}$, we see that $\bigcup_k A_{1,k}$ extends to bounded operators on H_{τ} . Finally, we can set $A_1 = (\bigcup_k A_{1,k})'' \subset B(H_{\tau})$. As a consequence of Perron Frobenius theory τ is the unique trace on $\bigcup_k A_{1,k}$ and so A_1 must be a factor, and A_1 is of course hyperfinite.

Similarly, define $A_0 = (\bigcup_k A_{0,k})'' \subset A_1$. A_0 must be a finite tracial von Neumann algebra, however, there is no reason for A_0 to be factor. One way to ensure that A_0 is a factor is to begin with a symmetric commuting square with $A_{i,0} \subset A_{i,1}$ connected inclusions. Then the inclusions $A_{0,k-1} \subset A_{0,k} \subset A_{0,k+1}$ are

instances of the basic construction and Perron Frobenius theory implies A_0 has a unique trace.

Theorem 2.3.1. (Wenzl's index formula)[Wen88] Let

$$\begin{array}{ccccccc} B_0 & \subset & B_1 & \subset & B_2 & \subset & \cdots & B \\ \cup & & \cup & & \cup & & & \cup \\ A_0 & \subset & A_1 & \subset & A_2 & \subset & \cdots & A \end{array}$$

be a sequence of commuting squares with a faithful trace, tr , on $\bigcup_n B_n$, $B = (\bigcup_n B_n)''$, and $A = (\bigcup_n A_n)''$. Further, assume that A and B are factors and the inclusion matrices for the square

$$\begin{array}{ccc} B_n & \xrightarrow{H_n} & B_{n+1} \\ K_n \cup & & \cup K_{n+1} \\ A_n & \xrightarrow{G_n} & A_{n+1} \end{array}$$

are **periodic** (i.e. there exists a period k such that, for all n , $G_n = G_{n+k}$, $K_n = K_{n+k}$, and $H_n = H_{n+k}$ for an identification of minimal central projections). Then $[B : A] = \|K_n\|$ for all n .

Theorem 2.3.2. (Ocneanu Compactness)[JS97] Let

$$\begin{array}{ccccccc} A_{1,0} & \subset & A_{1,1} & \subset & A_{1,2} & \subset & \cdots & A_1 \\ \cup & & \cup & & \cup & & & \cup \\ A_{0,0} & \subset & A_{0,1} & \subset & A_{0,2} & \subset & \cdots & A_0 \end{array}$$

be a collection of multi-matrix algebras obtained from a symmetric commuting square $A_{i,j}$, $i, j = 0, 1$ with its Markov trace, tr , by the basic construction. Then $A'_0 \cap A_1 = A'_{0,1} \cap A_{1,0}$.

Ocneanu compactness can also be used to compute higher relative commutants. In order to achieve this, the grid of finite dimensional algebras must be extended upwards.

Define $A_{2,k} = \{A_{1,k}, e_{A_0}\}''$, then by the commutativity of

$$\begin{array}{ccc} A_{1,k} & \subset & A_1 \\ \cup & & \cup \\ A_{0,k} & \subset & A_0 \end{array}$$

$A_{2,k} = \{a_0 + \sum_i a_i e_{A_0} a'_i | a_i, a'_i \in A_{1,k}\}$, and so $A_{2,k}$ is finite dimensional and $E_{A_1}(A_{2,k}) \subset A_{1,k}$. Thus

we have the diagram and inductive limits

$$\begin{array}{ccccccc}
A_{2,0} & \subset & A_{2,1} & \subset & A_{2,2} & \subset & \cdots & A_2 \\
\cup & & \cup & & \cup & & & \cup \\
A_{1,0} & \subset & A_{1,1} & \subset & A_{1,2} & \subset & \cdots & A_1 \\
\cup & & \cup & & \cup & & & \cup \\
A_{0,0} & \subset & A_{0,1} & \subset & A_{0,2} & \subset & \cdots & A_0
\end{array}$$

where each square is commuting. Since the original grid is symmetric, $A_{1,n} = \text{span } A_{0,n}A_{1,k}$ for $n > k$. In fact an ONB of A_1 over A_0 can be constructed such that the ONB belongs to $A_{1,0}$. Then $A_1 = \text{span } A_0A_{1,k} = \text{span } A_{1,k}A_0$ and so $A_2 = \text{span } A_{1,k}A_0e_{A_0}A_{1,k}$. Applying $E_{A_{2,k}}$ to both sides yields $A_{2,k} = \text{span } A_{1,k}e_{A_0}A_{1,k}$. This implies that $A_{0,k} \subset A_{1,k} \subset A_{2,k}$ is a basic construction for each k . To show that $A_{2,k-1} \subset A_{2,k} \subset A_{2,k+1}$ is a basic construction, observe that

$$\begin{aligned}
A_{2,k} &= \text{span } A_{1,k}e_{A_0}A_{1,k} = \text{span } A_{1,k-1}A_{0,k}e_{A_0}A_{0,k}A_{1,k-1} \\
&= \text{span } A_{1,k-1}e_{A_0}A_{0,k-1}e_{A_{1,k}}A_{1,k-1} \subset \text{span } A_{2,k-1}e_{A_{1,k}}A_{2,k-1}.
\end{aligned}$$

Therefore, we may extend the grid of symmetric commuting squares upwards and by Ocneanu compactness $A'_0 \cap A_k = A'_{0,1} \cap A_{k,0}$.

One might consider the general situation of a sequence of commuting squares with a coherent trace as we naturally get from the standard invariant. Ocneanu compactness certainly will not generalize, but Pimsner and Popa provide a generalization of the Wenzl index theorem in [PP86].

Proposition 2.3.3. [PP86] *Let*

$$\begin{array}{ccccccc}
B_0 & \subset & B_1 & \subset & B_2 & \subset & \cdots & B \\
\cup & & \cup & & \cup & & & \cup \\
A_0 & \subset & A_1 & \subset & A_2 & \subset & \cdots & A
\end{array}$$

be a sequence of commuting squares with a faithful trace, tr , on $\bigcup_n B_n$, $B = (\bigcup_n B_n)''$, and $A = (\bigcup_n A_n)''$. Letting $E_n: B_n \rightarrow A_n$ and $E: B \rightarrow A$ be the unique trace preserving conditional expectations then $Ind(E) = \lim_{n \rightarrow \infty} Ind(E_n)$.

CHAPTER 3

Planar Algebras

Planar algebras were constructed by V.F.R. Jones in order to analyze the standard invariant of subfactors. In particular, the standard invariant of a subfactor can be axiomatized in the language of planar algebras due to Jones or λ -lattices due to Popa. For more information see [Jon21] and [Pop95]. Consequently, planar algebras are a powerful tool for computations in and with the standard invariant and provide many methods to construct and analyze subfactors. The approach to planar algebras presented here follows the conventions and definitions in [Jon19].

Definition 3.0.1. A *vanilla planar tangle* T consists of the following data:

- (i) A smooth disc $D^T \subset \mathbb{R}^2$ called the *output disc*.
- (ii) A finite collection of disjoint smooth discs \mathfrak{D}_T that lie inside $\text{Int}(D^T)$ called the *input discs*.
- (iii) A finite collection of disjoint smooth curves \mathfrak{S}_T that lie inside $D^T - \bigcup_{D \in \mathfrak{D}_T} \text{Int}(D)$ such that its boundary points belong to the input discs or the boundary of the output disc and all curves meet discs transversely if at all. Elements of \mathfrak{S}_T are called *strings* of T .
- (iv) The boundary of each disc is broken into a finite number of components called the **boundary points** of D , the points in $\left(\bigcup_{s \in \mathfrak{S}_T} s \right) \cap \partial D$, and the **intervals** of D , the connected components of $\partial D - \bigcup_{s \in \mathfrak{S}_T} s$. Each disc has a single marked interval that we will denote with a $\$$. We will assign to each disc D boundary data ∂D . For vanilla planar tangles the only boundary data is a natural number $\partial D = n_D := \#(\text{boundary points of } D)$. Call a planar tangle T a n_{D^T} -tangle.

Example 3.0.2. Figure 3.1 is an example of a 9-tangle. Observe that closed loops are allowed in planar tangles.

Remark 3.0.3. Given a diffeomorphism θ of \mathbb{R}^2 and a planar tangle T , then $\theta(T)$ is also a planar tangle. This becomes clear with the observation that planar tangles are in one to one correspondence with the subsets of \mathbb{R}^2 obtained by $D^T - \left(\bigcup_{\mathfrak{D}_T} D \right) \cup \left(\bigcup_{\mathfrak{S}_T} s \right)$. Our goal is to define a multilinear map from a planar tangle up to orientation preserving diffeomorphisms. The main challenge to this goal is 'gluing' together two different tangles up to orientation preserving diffeomorphisms.

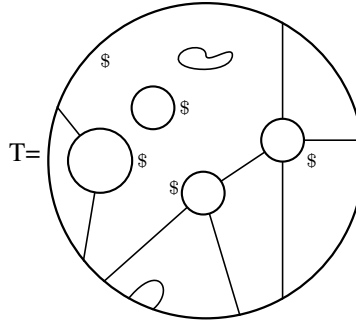
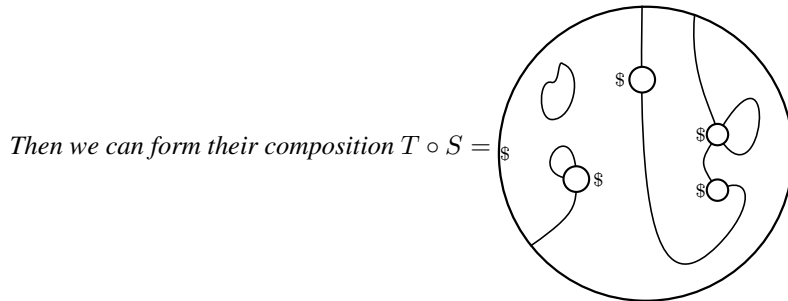
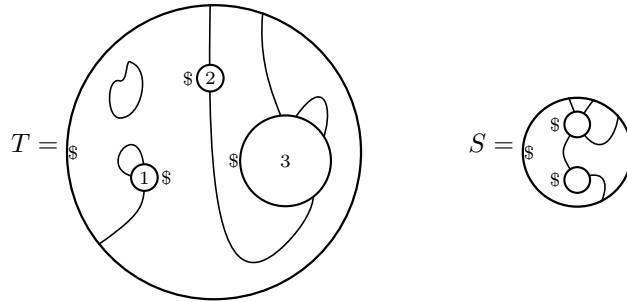

Figure 3.1: Vanilla Planar Tangle.

Definition 3.0.4. Given two tangles S, T embedded in the plane such that the marked and unmarked intervals of D^S coincide with the marked and unmarked intervals of the internal disc $D \in \mathfrak{D}_T$ and the union of an two strings of S, T that share a boundary point is a smooth curve. Then we may take the composition of these two tangles, $T \circ S$ where $\mathfrak{D}_{T \circ S} = \mathfrak{D}_T \cup \mathfrak{D}_S - D$, $D^{T \circ S} = D^T$, and $\mathfrak{S}_{T \circ S}$ is obtained by replacing the pairs of strings in $\mathfrak{S}_T \cup \mathfrak{S}_S$ with nontrivial intersection by their union.

Example 3.0.5. Let S and T be the tangles shown below where the discs D^S and $D_3 \in \mathfrak{D}_T$ coincide in \mathbb{R}^2 .



Definition 3.0.6. A *shaded planar tangle* is a planar tangle T with the additional data:

- (v) An assignment of shaded or unshaded to the connected regions of $D^T - \left(\bigcup_{\mathfrak{D}_T} D \right) \cup \left(\bigcup_{\mathfrak{S}_T} s \right)$ such that every string belongs to the boundary of a shaded region and an unshaded region.

For a tangle to admit a shading, it is necessary and sufficient for all discs to have an even number of boundary points. Thus let n_D be half the number of boundary points of D . Then we may classify the discs of a shaded planar tangle by the data $\partial D = (n_D, +)$ ($(n_D, -)$ resp.) if the marked interval of D is in the boundary of an unshaded region (a shaded region resp.).

Example 3.0.7. Figure 3.2 is a $(2, +)$ shaded planar tangle.

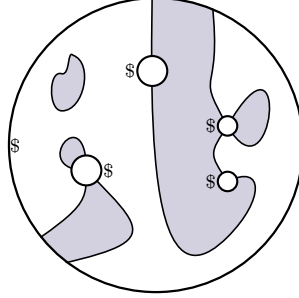

Figure 3.2: Shaded Planar Tangle

Remark 3.0.8. Just like vanilla planar tangles, shaded planar tangles are acted on by diffeomorphisms of \mathbb{R}^2 and if all the data fits, we may compose two shaded planar tangles.

Definition 3.0.9. A **unital shaded planar algebra** P is a family of vector spaces $P_{n,\pm}, n \in \mathbb{N} \cup \{0\}$ with multilinear maps

$$Z_T: \prod_{D \in \mathfrak{D}_T} P_{\partial D} \rightarrow P_{\partial D^T}$$

for every planar tangle T such that:

(i) If θ is an orientation preserving diffeomorphism of \mathbb{R}^2 , then $Z_{\theta(T)}(f) = Z_T(f \circ \theta)$.

(ii) $Z_{T \circ S} = Z_T \circ Z_S$ where $Z_T \circ Z_S(f) = Z_T(\tilde{f})$ and $\tilde{f} = \begin{cases} f(D) & \text{if } D \neq D^S \\ Z_S(f|_{\mathfrak{D}_S}) & \text{if } D = D^S \end{cases}$.

We will refer to elements of $\prod_{D \in \mathfrak{D}_T} P_{\partial D}$ as labellings of the tangle T . Unital here refers to the map Z_T from tangles without internal discs to $P_{n,\pm}$.

Definition 3.0.10. A unital shaded planar algebra is a ***-planar algebra** if each vector space $P_{k,\pm}$ is over \mathbb{C} and has an involution such that $Z_{\theta(T)}(f)^* = Z_T((f \circ \theta)^*)$ for all orientation reversing diffeomorphisms θ , tangles T , and labellings f .

Theorem 3.0.14. [Jon21] and [Pop95](see also [GJS10]) Every subfactor planar algebra with loop parameters $\delta_+ = \delta_- > 1$ arises as the standard invariant of an extremal finite index type II_1 subfactor.

Given a subfactor planar algebra, we may build the fusion algebra directly using the projection category of the planar algebra. The following summary of the projection category can be found in [BHP12] and in [Bis97]. Bisch shows the fusion algebra for $N - N$ bimodules can be obtained from the projection category by taking the complex linear span of irreducible objects in the projection category.

Definition 3.0.15. Let P be a subfactor planar algebra. Let the objects of the **projection category**, $Ob(Proj(P))$, be formal finite sums of projections in $P_{2n,+}$ for any $n \in \mathbb{N} \cup \{0\}$. Morphisms $x \in Mor(p, q)$ for $p \in Proj(P_{2n,+})$ and $q \in Proj(P_{2m,+})$, are elements of $P_{n+m,+}$ such that

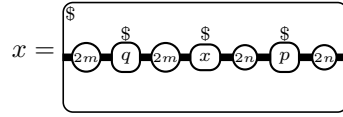

called **intertwiners** of projections. Composition of morphisms $x \in Mor(p, q)$ and $y \in Mor(q, r)$ for $p \in Proj(P_{2n,+})$, $q \in Proj(P_{2m,+})$, and $r \in Proj(P_{2l,+})$ is given by

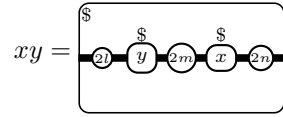

The morphisms between formal finite direct sums of projections are matrices of the intertwiners defined above. $Proj(P)$ is a tensor category when equipped with the tensor product

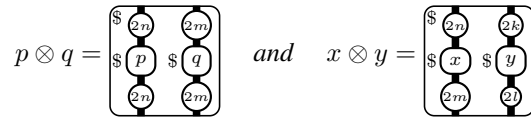

for projections p, q and morphisms x, y . This tensor product is extended linearly to formal finite direct sums as well. $Proj(P)$ also has a duality operation and adjoint. The duality operation on projections and morphisms is given by

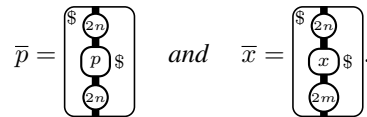

The adjoint on objects is the identity. For morphisms the adjoint is the $*$ -transpose.

Such a category is an example of a rigid C^* -tensor category, a definition of which can be found in

[BHP12]. Then the fusion algebra of a subfactor is given by the complex linear span of equivalence classes of irreducible objects in $Proj(P^{N \subset M})$ with addition given by formal direct sums, multiplication by the tensor product, and the adjoint is the conjugate duality operation of complex linear combinations of projections.

We now define the spin planar algebra (see [Jon21]).

Definition 3.0.16. Fix a natural number Q . Let $P_{0,+}^{spin} = \mathbb{C}$, $P_{0,-}^{spin} = \mathbb{C}^Q$ and $P_{n,\pm}^{spin} = (\mathbb{C}^Q)^{\otimes n}$ where elements in $P_{n,\pm}^{spin}$ correspond to a disk with $2n$ boundary points and n shaded intervals. Fix an inner product and a basis $B = \{\hat{1}, \dots, \hat{Q}\}$ on \mathbb{C}^Q . Vectors $v \in (\mathbb{C}^Q)^{\otimes n}$ are a (unique) linear combination of simple tensors $B^{\otimes n} = \{\otimes_{i=1}^n \hat{s}_i \mid \hat{s}_i \in B\}$, $v = \sum_{\hat{b} \in B^{\otimes n}} v_b \hat{b}$, $v_b \in \mathbb{C}$. Then the following rules will equip these vector spaces with a unital shaded $*$ -planar algebra structure.

- (i) A state on a shaded planar tangle is a map $\sigma: \{\text{connected shaded regions of } T\} \rightarrow \{\hat{1}, \dots, \hat{Q}\}$.
- (ii) For each disc $D \in \mathfrak{D}_T$, a state σ induces the following labelling of shaded intervals of D . Count the shaded intervals of D in a counter clockwise direction starting after the marked interval. Set $\sigma_D = \otimes_{i=1}^{n_D} s_i$ where the i^{th} shaded interval belongs to the boundary of a region labelled by $s_i \in B$. If D has no shaded intervals then $\sigma_D = 1$.
- (iii) Define $(\otimes_{i=1}^n s_i)^* = \otimes_{i=1}^n s_{n-i+1}$ for $\otimes_{i=1}^n s_i \in P_{n,+}^{spin}$ and $(\otimes_{i=1}^n s_i)^* = \otimes_{i=1}^{n-1} s_{n-i} \otimes s_n$ for $\otimes_{i=1}^n s_i \in P_{n,-}$ then extend $*$ to $P_{n,\pm}^{spin}$ by conjugate linearity. For example,

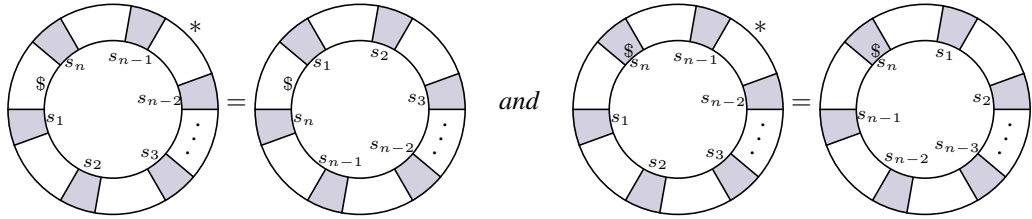

- (iv) Then we may define the action of a tangle T on P^{spin} with a labelling $f \in \prod_{D \in \mathfrak{D}_T} P_{\partial D}$ by

$$Z_T^{spin}(f) = \sum_{\sigma} \prod_{D \in \mathfrak{D}_T} f(D)_{\sigma_D} \sigma_{D^T},$$

where n_T is the number of shaded intervals in the output disk, $f(D) = \sum_{\hat{b} \in B^{\otimes n}} f(D)_b \hat{b}$ for $n = n_D$, and an empty product is interpreted as 1.

This is the **spin planar algebra** denoted by P^{spin} . The shaded planar algebra P^{Spin} has the same underlying

vector space as P^{Spin} and is obtained from P^{Spin} with the modifications to the action below.

(v) Given a shaded planar tangle T and a region r in T , define $Rot(r)$ as follows: Remove input disks with zero boundary points. Then give r a counter-clockwise orientation inducing an orientation on the boundary of r which is a union of piecewise smooth curves. Define $Rot(r)$ as the rotation number of the oriented boundary of r .

(vi) Given a shaded planar tangle T , define

$$Rot(T) = \prod_{\substack{\text{shaded regions} \\ r \text{ of } T}} \left(\frac{1}{\sqrt{Q}} \right)^{Rot(r)}.$$

(vii) Finally, we define the action of a tangle T on P^{Spin} with a labelling $f \in \times_{D \in \mathfrak{D}_T} P_{\partial D}^{Spin}$ by

$$Z_T^{Spin}(f) = \sqrt{Q}^{n_T} Rot(T) Z_T^{Spin}(f).$$

This normalization makes the loop parameters of P^{Spin} equal to each other, $\delta_+ = \delta_- = \sqrt{Q}$.

To illustrate the action of tangle on P^{Spin} consider the following example. Fix $Q = 5$ and let $x = \hat{1} \otimes \hat{2}$, $y = \hat{2} \otimes \hat{3}$. Then we can evaluate the tangle

$$\begin{array}{|c|} \hline \$ \\ \hline a \quad x \quad b \quad y \quad c \\ \hline d \\ \hline \end{array} = \sum_{a,b,c,d} \sqrt{5}^3 \left(\frac{1}{\sqrt{5}} \right)^4 x_{\hat{a} \otimes \hat{b}} y_{\hat{b} \otimes \hat{c}} \hat{a} \otimes \hat{d} \otimes \hat{c} = \frac{1}{\sqrt{5}} \sum_{d=1}^5 \hat{1} \otimes \hat{d} \otimes \hat{3}.$$

We work with P^{Spin} in this dissertation since both of its loop parameters δ_+ and δ_- are equal and the type II Reidemeister moves we will perform later have a cleaner presentation.

Proposition 3.0.17. ([Jon21],[Jon19]) P^{Spin} is a shaded C^* -planar algebra i.e. each $P_{n,\pm}^{Spin}$ becomes a C^* -algebra with the multiplication tangle

$$xy = \begin{array}{|c|} \hline \$ \\ \hline \circ \quad x \quad \circ \quad y \quad \circ \\ \hline \end{array}$$

and the $*$ -operation. Furthermore, P^{Spin} has loop parameters

$$\delta_+ = \begin{array}{|c|} \hline \$ \\ \hline \circ \quad \circ \\ \hline \end{array} = \sqrt{Q} \cdot id \quad \text{and} \quad \delta_- = \begin{array}{|c|} \hline \$ \\ \hline \circ \quad \circ \\ \hline \end{array} = \sqrt{Q} \cdot id.$$

$\dim(P_{2,+}^{Spin}) = Q^2$, $P_{2,+}^{Spin} \cong M_Q(\mathbb{C})$ and so $P_{0,+}^{Spin} \subset P_{1,+}^{Spin} \subset P_{2,+}^{Spin}$ is a basic construction. By an identical argument, $P_{2n,+}^{Spin} \cong M_{Q^n}(\mathbb{C})$ and $P_{2n+1}^{Spin} \cong M_{Q^n}(\mathbb{C}) \otimes \Delta_Q$ imply that $P_{2n+2,+}^{Spin} \cong M_{Q^{n+1}}(\mathbb{C})$. Therefore $\mathbb{C} = P_{0,+}^{Spin} \subset P_{1,+}^{Spin} \subset P_{2,+}^{Spin} \subset \dots$ is a basic construction and we have identified the algebras and Jones projections. \square

Remark 3.1.2. We may realize the isomorphisms of algebras above with

$$M_{Q^n}(\mathbb{C}) \rightarrow P_{2n,+}^{Spin} \text{ by } e_{i_1,j_1} \otimes \dots \otimes e_{i_n,j_n} \mapsto \sqrt{Q}^n \hat{i}_1 \otimes \dots \otimes \hat{i}_n \otimes \hat{j}_n \otimes \dots \otimes \hat{j}_1 \text{ and}$$

$$M_{Q^n}(\mathbb{C}) \otimes \Delta_Q \rightarrow P_{2n+1,+}^{Spin} \text{ by } e_{i_1,j_1} \otimes \dots \otimes e_{i_n,j_n} \otimes e_{k,k} \mapsto \sqrt{Q}^n \hat{i}_1 \otimes \dots \otimes \hat{i}_n \otimes \hat{k} \otimes \hat{j}_n \otimes \dots \otimes \hat{j}_1$$

where the $e_{i,j}$'s are matrix units of $M_Q(\mathbb{C})$.

Definition 3.1.3. Given a shaded planar algebra P , a pair of elements, $u, v \in P_{2,+}$, is called **bi-invertible** if $uv = 1$ and $\rho(u)\rho^{-1}(v) = \frac{\delta_-}{\delta_+} 1$. In terms of planar diagrams

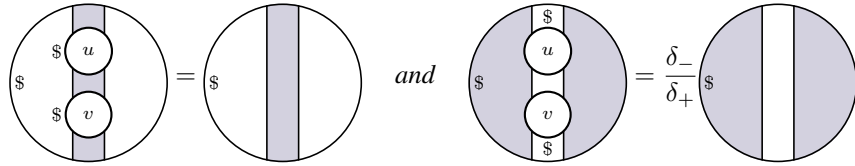

If u is also a unitary then $v = u^*$ and we call u a **biunitary**.

Definition 3.1.4. ([Jon21],[Jon19]) A $Q \times Q$ complex matrix, H , is called a complex Hadamard matrix if $HH^* = QI$ and $|H_{i,j}| = 1$ for all i, j . Define $u = \sum_{i,j=1}^Q H_{i,j} \hat{i} \otimes \hat{j} \in P_{2,+}^{Spin}$ and observe that u satisfies the following equalities

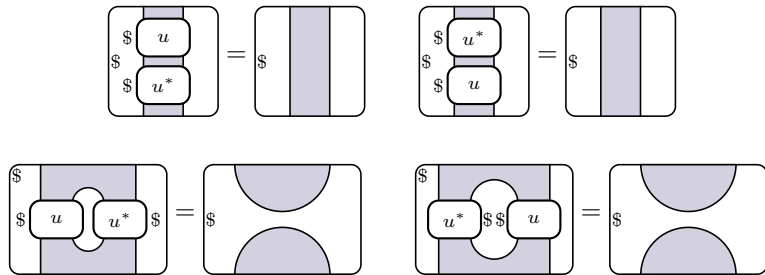

One might expect the first equality above to yield $Q \cdot id_{P_{2,+}^{Spin}}$, but the action of the planar operad on P^{Spin} absorbs the factor of Q . We encourage the reader to verify the equalities in P^{Spin} . Observe that these are equivalent to type II Reidemeister moves and so we will adopt notation from knot theory for u and u^* .

Let

$$\begin{array}{c} \text{circle with } \rightarrow \text{ in right half} \\ \text{circle with } \rightarrow \text{ in right half and } u \text{ in center} \end{array} = \begin{array}{c} \text{circle with } \rightarrow \text{ in right half} \\ \text{circle with } \rightarrow \text{ in right half and } u^* \text{ in center} \end{array} \text{ and}$$

then we have the type II Reidemeister moves

$$\begin{array}{c} \text{circle with } \rightarrow \text{ in right half and } \text{circle with } \rightarrow \text{ in left half} \\ \text{circle with } \rightarrow \text{ in right half and } \text{circle with } \rightarrow \text{ in left half} \end{array} = \begin{array}{c} \text{circle with } \rightarrow \text{ in right half} \\ \text{circle with } \rightarrow \text{ in left half} \end{array} \text{ and}$$

$$\Delta_Q \subset M_Q(\mathbb{C})$$

Let u be a biunitary in the sense of proposition 2.2.6 with respect to the square $\begin{array}{c} \mathbb{C} \\ \cup \\ \mathbb{C} \end{array}$ and

$$\mathbb{C} \subset u\Delta_Q u^*$$

the unique trace on $M_Q(\mathbb{C})$. Identify $u, v \in P_{2,+}^{Spin}$ by $u = \sqrt{Q} \sum_{i,j=1}^Q u_{i,j} \hat{i} \otimes \hat{j}$ and $v = u^*$ we see that these two notions of biunitarity coincide. Furthermore, these conditions are equivalent to u being $\frac{1}{\sqrt{Q}}$ times a complex Hadamard matrix.

Proposition 3.1.5. *Given a complex Hadamard matrix u let*

$$\psi_{u,n}(x) = \begin{array}{c} \text{circle with } \rightarrow \text{ in right half and } x \text{ in center} \\ \text{circle with } \rightarrow \text{ in right half and } x \text{ in center} \end{array} \text{ and } \varphi_{u,n}(x) = \begin{array}{c} \text{circle with } \rightarrow \text{ in right half and } x \text{ in center} \\ \text{circle with } \rightarrow \text{ in right half and } x \text{ in center} \end{array} \text{ for } x \in P_{n,+}^{Spin}.$$

where we have omitted the shading as it depends on the parity of k .

Then $\psi_{u,n}, \varphi_{u,n}: P_{n,+}^{Spin} \rightarrow P_{n+1,+}^{Spin}$ are injective unital trace preserving $*$ -algebra homomorphisms such that $\psi_{u,n} \circ i_{n-1} = i_n \circ \psi_{u,n-1}$ and $\varphi_{u,n} \circ i_{n-1} = i_n \circ \varphi_{u,n-1}$. Thus $\{\psi_{u,n}\}_n$ and $\{\varphi_{u,n}\}_n$ induce endomorphisms ψ_u, φ_u on $(\bigcup_n P_{n,+}^{Spin})''$. Furthermore, $\psi_u(e_n) = e_{n+1}$ and $\varphi_u(e_n) = e_{n+1}$.

Proof. These maps being trace preserving and unital algebra homomorphisms follow immediately from type II Reidemeister moves. The fact that they are $*$ -homomorphisms follows from

$$\begin{array}{c} \text{circle with } \rightarrow \text{ in right half and } * \\ \text{circle with } \rightarrow \text{ in right half and } * \end{array} = \begin{array}{c} \text{circle with } \rightarrow \text{ in right half and } * \\ \text{circle with } \rightarrow \text{ in right half and } * \end{array} \text{ and } \begin{array}{c} \text{circle with } \rightarrow \text{ in right half and } * \\ \text{circle with } \rightarrow \text{ in right half and } * \end{array} = \begin{array}{c} \text{circle with } \rightarrow \text{ in right half and } * \\ \text{circle with } \rightarrow \text{ in right half and } * \end{array}.$$

The compatibility between $\psi_{u,k}, \varphi_{u,k}$ and i_k comes directly from type II Reidemeister moves. For example

$$\begin{array}{c} \text{circle with } \rightarrow \text{ in right half and } x \text{ in center} \\ \text{circle with } \rightarrow \text{ in right half and } x \text{ in center} \end{array} = \begin{array}{c} \text{circle with } \rightarrow \text{ in right half and } x \text{ in center} \\ \text{circle with } \rightarrow \text{ in right half and } x \text{ in center} \end{array}.$$

Injectivity then follows from faithfulness of the trace.

Due to the compatibility with inclusion maps, we can define $\psi_u, \varphi_u: \bigcup_n P_{n,+}^{Spin} \rightarrow \bigcup_n P_{n,+}^{Spin}$ by

$\psi_u(x) = \psi_{u,n}(x)$ for $x \in P_{k,+}^{Spin}$ and $\psi_u(x) = \psi_{u,n}(x)$ for $x \in P_{k,+}^{Spin}$. Furthermore, ψ_u and φ_u extend to the weak closures since they are trace preserving. Finally, observe that

$$\psi_u(e_n) = \frac{1}{\sqrt{Q}} \left[\text{Diagram 1} \right] = \frac{1}{\sqrt{Q}} \left[\text{Diagram 2} \right] = e_{n+1} \text{ and similarly } \varphi_u(e_n) = e_{n+1}. \quad \square$$

Remark 3.1.6. The homomorphisms ψ_u and φ_u provide a description of the spin model and the basic constructions coming from the spin model. This is immediate from the observation that

$$\psi_u(x) = \left[\text{Diagram 3} \right] = \left[\text{Diagram 4} \right] = uxu^* \text{ and so } \begin{array}{ccc} \Delta_Q \subset M_Q(\mathbb{C}) & P_{1,+}^{Spin} \subset & P_{2,+}^{Spin} \\ \cup & \cup & \cong \cup & \cup \\ \mathbb{C} \subset u\Delta_Q u^* & \mathbb{C} \subset & \psi_u(P_{1,+}^{Spin}) \end{array} .$$

Furthermore, since $\psi_u(e_n) = e_{n+1}$, the basic construction of the spin model is

$$\left(\begin{array}{cc} P_{n,+}^{Spin} & \subset & P_{n+1,+}^{Spin} \\ \cup & & \cup \\ \psi_u(P_{n-1,+}^{Spin}) & \subset & \psi_u(P_{n,+}^{Spin}) \end{array} \right)_{n \geq 1}$$

and so the subfactor $\psi_u \left(\left(\bigcup_k P_{k,+}^{Spin} \right)'' \right) \subset \left(\bigcup_k P_{k,+}^{Spin} \right)''$ has index Q . Going forward $N \subset M$ will refer to this irreducible subfactor coming from the spin model and $N \subset M \subset M_1 \subset \dots \subset M_k \subset \dots$ its basic construction. Similarly, we can deal with the vertical subfactor coming from the spin model. Observe that

$$\begin{array}{ccc} \Delta_Q \subset M_Q(\mathbb{C}) & \psi_{u^*}(P_{1,+}^{Spin}) \subset & P_{2,+}^{Spin} \\ \cup & \cup & \cong \cup & \cup \\ \mathbb{C} \subset u\Delta_Q u^* & \mathbb{C} \subset & P_{1,+}^{Spin} \end{array} \text{ by the map } Ad_{u^*} .$$

Then the vertical subfactor of the spin model is isomorphic to $\psi_{u^*} \left(\left(\bigcup_k P_{k,+}^{Spin} \right)'' \right) \subset \left(\bigcup_k P_{k,+}^{Spin} \right)''$. Let $P \subset R$ and $P \subset R \subset R_1 \subset \dots \subset R_k \subset \dots$ denote the vertical subfactor and its basic construction. In the next section we will use Ocneanu compactness and the planar algebra description of the vertical subfactor to describe the higher relative comutants of $N \subset M$. In general, very little is known about the standard invariants of spin model subfactors. However, $N \subset M$ has been shown to be a Bisch-Haagerup subfactor when the complex Hadamard matrix is a twisted tensor product of group Hadamard matrices.

Definition 3.1.7. Let G be a finite abelian group. There is a canonical group isomorphism between G and its Pontryagin dual \hat{G} , $\theta: G \rightarrow \hat{G}$. Associated to G is a $|G| \times |G|$ complex Hadamard matrix $H_G =$

$l^\infty(G) \subset M_{|G|}(\mathbb{C})$

$(\theta_g(h))_{g,h}$ which yields the biunitary connection for $\bigcup_{g,h} \bigcup_{k,l} \mathbb{C} \subset \mathbb{C}[G]$, $u_G = \frac{1}{\sqrt{|G|}} H_G$. This complex Hadamard matrix is called the **group Hadamard matrix**.

Example 3.1.8. When $G \cong \mathbb{Z}_n$, we have the group Hadamard matrix, $H = (e^{2\pi ikl/n})_{0 \leq k,l \leq n-1}$, and $u_{\mathbb{Z}_n} = \frac{1}{\sqrt{n}} H$ called the **Fourier matrix**.

Theorem 3.1.9. [Bur15] Let G and K be finite abelian groups and $T \in \Delta_{|G|,|K|}$ a unitary. Then the subfactor obtained from the spin model corresponding to the complex Hadamard matrix $u = (1 \otimes H_K)T(H_G \otimes 1)$ is Bisch-Haagerup (i.e. $R^G \subset R \rtimes K$).

Remark 3.1.10. The construction $H = (1 \otimes H_K)T(H_G \otimes 1)$ in the theorem above are often referred to as **twisted tensor products** with a twist T . Since Bisch-Haagerup subfactors are well understood the standard invariant for these spin models can be computed. For more information see [BH96] and [BDG09].

3.2 The Angle Operator and Flat Elements

We have already seen how the spin planar algebra provides a description of the spin model subfactor associated to a Hadamard matrix H . The first goal for this section is to use the spin planar algebra along with Ocneanu compactness to describe the relative commutants of $P \subset R$. We will also identify the von Neumann algebra generated by the relative commutants as the intersection of two subalgebras of M . The general situation

$N \subset M$

tion $\bigcup_{L,N} \bigcup_{L,N} N \cap L \subset L$ where L and N are finite index von Neumann algebras has been studied by Sano and Watatani in [SW94] using an angle operator corresponding to the square of algebras. This observation is due to V.F.R. Jones and motivates this investigation of the angle operator from the spin model and how it relates to the relative commutants. The following results can be found in [Jon19].

Remark 3.2.1. Applying Ocneanu compactness to $P \subset R_n$ using the symmetric commuting square,

$$\begin{array}{ccc} P_{1,+}^{Spin} & \subset & P_{n+1,+}^{Spin} \\ \cup & & \cup \\ \mathbb{C} & \subset & \psi_u(P_{n,+}^{Spin}) \end{array},$$

we find that $P' \cap R_{n-1} \cong (P_{1,+}^{Spin})' \cap \psi_u(P_{n,+}^{Spin})$ inside $P_{n+1,+}^{Spin}$. Observe that $(P_{1,+}^{Spin})' \cap P_{n+1,+}^{Spin}$ is given by

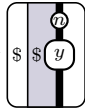
elements of the form  where $y \in P_{n,-}^{Spin}$. Therefore $\psi_u(x) \in P_{n+1,+}^{Spin}$ belongs to $(P_{1,+}^{Spin})' \cap \psi_u(P_{n,+}^{Spin})$

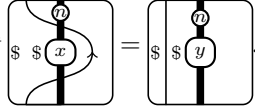
iff there exists an $y \in P_{n,-}^{Spin}$ such that 

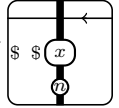
Definition 3.2.2. We will call $x \in P_{n,\pm}^{Spin}$ **flat** with respect to u if there exists $y \in P_{n,\mp}^{Spin}$ such that 

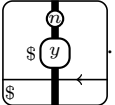
 The flat elements with respect to u clearly form a unital subalgebra of $P_{n,\pm}^{Spin}$ that we will denote by $P_{n,\pm}^u$.

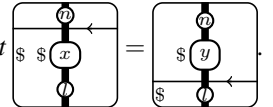
Proposition 3.2.3. x is flat with respect to u iff $\psi_u(x) \in (P_{1,+}^{Spin})' \cap \psi_u(P_{k,+}^{Spin})$. Furthermore, for n, l such that $n + l = 2k$, these are both equivalent to the existence of a $y \in P_{k,-}^{Spin}$ such that 

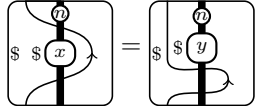
Proof. Let $n + l = 2k$ and $x \in P_{k,+}^{Spin}$. If there exists an $y \in P_{k,-}^{Spin}$ such that  then after applying type II Reidemeister moves we see that $\psi_u(x) \in (P_{1,+}^{Spin})' \cap \psi_u(P_{k,+}^{Spin})$. A similar argument provides the opposite inclusion. \square

Theorem 3.2.4. [Jon19] P^u is a planar subalgebra of P^{Spin} .

Proof. Our goal is to show that $Z_T(f)$ is flat whenever $f \in \times_{D \in \mathcal{D}_T} P_{\partial D}^u$. To prove this we will decompose an arbitrary tangle T with unshaded marked intervals.

First, we may represent input discs, D , in T by cusps with all the strings connected to D meeting at a point. Since there are only finitely many discs we only have finitely many cusps. For each string $s \in \mathcal{S}_T$ we have the smooth height function given by the projection $\pi_y : s \rightarrow \mathbb{R}$. As a consequence of Sard's theorem and Morse theory π_y can be uniformly approximated by smooth functions with isolated critical points. Furthermore, it is possible to perturb T so the finitely many critical points and cusps have disjoint image under π_y . Thus we may slice T into a sequence of annular tangles that only contain one critical point or cusp. These annular tangles must be one of the following

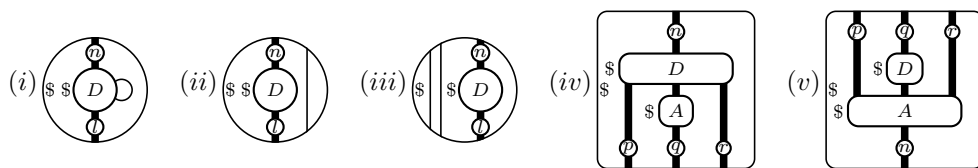

where l, n, p, q and r are constants such that all marked intervals are unshaded. It is now an easy computation to show that each of these tangles is flat, provided the inputs A and D are also flat. Therefore $Z_T(f)$ must be flat whenever $f \in \bigtimes_{D \in \mathcal{D}_T} P_{\partial D}^u$. \square

We will now compute the first two relative commutants of $P \subset R$ directly. The flatness condition will make this computation much more manageable.

Proposition 3.2.5. [Jon21] $P_{0,+}^u$ and $P_{1,+}^u$ are isomorphic to \mathbb{C} and so $P \subset R$ is an extremal subfactor. Furthermore, $P_{2,+}^u$ is abelian.

Proof. $\dim(P_{0,+}^u) = 1$ is immediate since $\dim(P_{0,+}^{Spin}) = 1$.

Let x_i and y_i be the \hat{i} coefficients of $x, y \in \mathbb{C}^Q \cong P_{1,\pm}^{Spin}$. Consider the following state on the flatness condition for y and x :

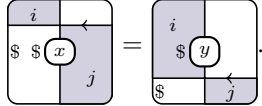

This is equivalent to the equation $\bar{u}_{i,j}x_j = \bar{u}_{i,j}y_i$ for all $i, j \in \{1, \dots, Q\}$. Since entries in u have modulus 1, we have $x_j = y_i$ for all i, j and so $x \in \mathbb{C} \cdot 1$.

Finally, observe that $P_{2,-}^{Spin} \cong \Delta_Q \otimes \Delta_Q$ and so $P_{2,-}^u$ is abelian. We also have an anti-isomorphism $\rho^3 \circ \psi_u: P_{2,+}^u \rightarrow P_{2,-}^u$ given by $\rho^3 \circ \psi_u(x) =$

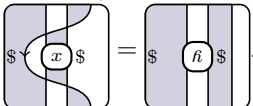

Therefore $P_{2,+}^u \cong P' \cap R_1$ is also abelian. \square

Remark 3.2.6. Since $P_{2,+}^u$ is abelian, $P' \cap R_1 \cong \mathbb{C}^k$ where k is the number of minimal projections in $P_{2,+}^u$. In order to compute the minimal projections of this algebra we will need to take a closer look at the complex Hadamard matrix we are using. Observe that the flatness condition for x and y

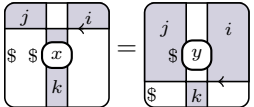

corresponds to the equation $\frac{1}{\sqrt{Q}} \sum_l x_{k,l} u_{i,l} \bar{u}_{j,l} = y_{i,j} u_{i,k} \bar{u}_{j,k}$. This equation says x

has eigenvectors $v_{i,j} = \sum_{l=1}^Q u_{i,l} \bar{u}_{j,l} \hat{l} \in P_{1,+}^{Spin}$ with eigenvalues $y_{i,j}$, i.e.

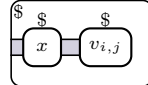

$= y_{i,j} v_{i,j}$.

Definition 3.2.7. [Jon21] Define the $Q^2 \times Q^2$ **profile matrix** $Prof(u)$ by

$$Prof(u)_{a,b}^{c,d} = \sum_{l=1}^Q u_{a,l} \bar{u}_{b,l} \bar{u}_{c,l} u_{d,l}.$$

From this matrix we will define the directed graph \mathcal{G}_u on Q^2 vertices by $(a, b) \rightarrow (c, d)$ iff

$$Prof(u)_{a,b}^{c,d} \neq 0.$$

Theorem 3.2.8. [Jon21] The minimal projections of the abelian algebra $P_{2,+}^u$ are in bijection with the

connected components of \mathcal{G}_u . Furthermore, if p_C is the projection corresponding to component C then $\text{tr}(p_C) = \frac{|C|}{Q^2}$.

Proof. Let p be a minimal projection of $P_{2,+}^u$ and $v_{i,j} = \sum_{l=1}^Q u_{i,l} \bar{u}_{j,l} \hat{l} \in P_{1,+}^{Spin}$. Then $p v_{i,j} = y_{i,j} v_{i,j}$ where $y_{i,j}$ is zero or one since p is a projection and $v_{i,j}$ is an eigenvector. Suppose that $p v_{a,b} = v_{a,b}$ and (a,b) is adjacent to (c,d) in \mathcal{G}_u . Then $\langle v_{a,b} | v_{c,d} \rangle_{Spin} = \left\langle \begin{array}{|c|} \hline v_{c,d}^* \\ \hline v_{a,b} \\ \hline \end{array} \right\rangle = \frac{1}{\sqrt{Q}} \text{Prof}(u)_{a,b}^{c,d} \neq 0$ and so $p v_{c,d} = v_{c,d}$. Therefore $p v_{i,j} = v_{i,j}$ for all (i,j) in the connected component of (a,b) .

Conversely, let C be the connected component of (a,b) and let p_C denote the orthogonal projection onto the subspace of $P_{1,+}^{Spin}$ generated by $\{v_{i,j} | (i,j) \in C\}$. Then each $v_{i,j}$ is an eigenvector of p_C and so $p_C \in P_{2,+}^u$. Since p is minimal and $p \leq p_C$, $p = p_C$. We can also compute the trace of p_C directly, since $y_{i,j} = 1$ for exactly $|C|$ pairs (i,j) . Setting $y = \sum_{(i,j)} y_{i,j} \hat{i} \otimes \hat{j}$, we have

$$\text{tr}(p) = \frac{1}{\sqrt{Q^3}} \left\langle \begin{array}{|c|} \hline p \\ \hline \end{array} \right\rangle = \frac{1}{\sqrt{Q^3}} \left\langle \begin{array}{|c|} \hline y \\ \hline \end{array} \right\rangle = \frac{|C|}{Q^2}$$

□

Proposition 3.2.9. *Let u be a $4n \times 4n$ real Hadamard matrix with $n \geq 3$ and odd. Then $P_{2,+}^u$ is two dimensional.*

Proof. By the previous theorem it suffices to show that profile matrix has two connected components. We will first show that $\text{Prof}(u)_{a,b}^{c,d} \neq 0$ whenever a, b, c , and d are distinct.

Let a, b, c , and d be distinct and define four vectors $\vec{1} = (1)_{l=1}^{4n}$, $\nu^b = (u_{a,l} u_{b,l})_{l=1}^{4n}$, $\nu^c = (u_{a,l} u_{c,l})_{l=1}^{4n}$, and $\nu^d = (u_{a,l} u_{d,l})_{l=1}^{4n}$. Since a, b, c , and d are distinct $\vec{1}$, ν_b , ν_c , and ν_d are mutually orthogonal. Define the following sets for $\epsilon, \delta, \eta \in \{+, -\}$,

$$S_{\epsilon\delta\eta} = \{l = 1, \dots, 4n | \nu_l^b = \epsilon 1, \nu_l^c = \delta 1, \nu_l^d = \eta 1\}.$$

Since

$$\text{Prof}(u)_{a,b}^{c,d} = \sum_{l=1}^Q u_{a,l} \bar{u}_{b,l} \bar{u}_{c,l} u_{d,l} = \sum_{l=1}^Q (u_{a,l} u_{b,l}) (u_{a,l} u_{c,l}) (u_{a,l} u_{d,l}),$$

we have that

$$Prof(u)_{a,b}^{c,d} = |S_{+++}| + |S_{--+}| + |S_{-+-}| + |S_{+--}| - |S_{-++}| - |S_{+-+}| - |S_{++-}| - |S_{---}|.$$

By definition $\sum_{\epsilon, \delta, \eta \in \{+, -\}} |S_{\epsilon\delta\eta}| = 4n$ and since ν_c and ν_d are orthogonal to $\vec{1}$

$$\sum_{\epsilon, \delta \in \{+, -\}} |S_{\epsilon\delta+}| = \sum_{\epsilon, \delta \in \{+, -\}} |S_{\epsilon\delta-}| = 2n = \sum_{\epsilon, \eta \in \{+, -\}} |S_{\epsilon+\eta}| = \sum_{\epsilon, \eta \in \{+, -\}} |S_{\epsilon-\eta}|,$$

$$\text{and so } \sum_{\epsilon \in \{+, -\}} |S_{\epsilon++}| - |S_{\epsilon--}| = \sum_{\epsilon \in \{+, -\}} |S_{\epsilon+-}| - |S_{\epsilon-+}|$$

$$\text{and } \sum_{\epsilon \in \{+, -\}} |S_{\epsilon++}| - |S_{\epsilon--}| = \sum_{\epsilon \in \{+, -\}} |S_{\epsilon-+}| - |S_{\epsilon+-}|.$$

Together, these imply that

$$\sum_{\epsilon \in \{+, -\}} |S_{\epsilon++}| = \sum_{\epsilon \in \{+, -\}} |S_{\epsilon--}| \text{ and } \sum_{\epsilon \in \{+, -\}} |S_{\epsilon+-}| = \sum_{\epsilon \in \{+, -\}} |S_{\epsilon-+}|.$$

Since ν_c and ν_d are orthogonal

$$\sum_{\epsilon \in \{+, -\}} |S_{\epsilon++}| + |S_{\epsilon--}| = \sum_{\epsilon \in \{+, -\}} |S_{\epsilon+-}| + |S_{\epsilon-+}|$$

$$\text{and so } \sum_{\epsilon \in \{+, -\}} |S_{\epsilon++}| = \sum_{\epsilon \in \{+, -\}} |S_{\epsilon+-}| \text{ and } \sum_{\epsilon \in \{+, -\}} |S_{\epsilon--}| = \sum_{\epsilon \in \{+, -\}} |S_{\epsilon-+}|.$$

Hence, for all $\delta, \eta \in \{+, -\}$ $\sum_{\epsilon \in \{+, -\}} |S_{\epsilon, \delta, \eta}| = n$. The same argument implies that $\sum_{\delta \in \{+, -\}} |S_{\epsilon, \delta, \eta}| = n$

for all $\epsilon, \eta \in \{+, -\}$ and $\sum_{\eta \in \{+, -\}} |S_{\epsilon, \delta, \eta}| = n$ for all $\epsilon, \delta \in \{+, -\}$. Letting $|S_{+++}| = k$ we find that

$$Prof(u)_{a,b}^{c,d} = 8k - 4n \neq 0 \text{ since } n \text{ is odd and } k \text{ is an integer.}$$

Then \mathcal{G}_u has two components given by sets of vertices $\{(a, a) | a = 1, \dots, 4n\}$ and $\{(a, b) | a \neq b\}$. The first component is obviously connected since $Prof(u)_{a,a}^{b,b} = 4n$ and so it is the complete graph. Since $4n > 5$ we may pick five distinct numbers a, b, c, d , and e from $1, \dots, 4n$. Then we have edges $(a, b) \rightarrow (c, d) \rightarrow (a, e)$ and $(a, b) \rightarrow (c, d) \rightarrow (b, a)$ which connect all vertices in the second component. In fact, all vertices in the second component are at most a distance of two apart. \square

Definition 3.2.10. Let $1 \otimes : P_{n,-}^{Spin} \rightarrow P_{n+1,+}^{Spin}$ denote the trace preserving $*$ -algebra morphism

sition of $P' \cap R_{2n-1}$ and $\overrightarrow{s^{(n)}} = (s_k^{(n)})_{1 \leq k \leq k_n}$ the trace vector for $P' \cap R_{2n-1}$. Since $\psi_u(P_{2n,+}^{Spin}) \cong M_{Q^n}(\mathbb{C})$, it is a factor with trace vector $\overrightarrow{t^{(n)}} = (\frac{1}{Q^n})$ and $P' \cap R_{2n-1} \subset \psi_u(P_{2n,+}^{Spin})$ has an inclusion matrix of the form $G = (g_{k,l})_{1 \leq k \leq k_n, l=1}$ where the $g_{k,1} \geq 1$ are integers. Since the traces must be compatible $s_k^{(n)} = \frac{g_{k,1}}{Q^n}$. Then by theorem 2.1.4, $Ind(E_n) = \sum_{k=1}^{k_n} \min\{g_{k,1}, d_k\} g_{k,1} \geq k_n$ where E_n is the unique trace preserving condi-

$$\psi_u(P_{2n,+}^{Spin}) \subset \psi_u(P_{2n+2,+}^{Spin})$$

tional expectation for $P' \cap R_{2n-1} \subset \psi_u(P_{2n,+}^{Spin})$. Since $\bigcup \bigcup$ is a commuting

$$P' \cap R_{2n-1} \subset P' \cap R_{2n+1}$$

square for all n we may apply proposition 2.3.3 and so $Ind(E_{N \cap L}^M) = \lim_{n \rightarrow \infty} Ind(E_n) \geq \lim_{n \rightarrow \infty} k_n = \infty$. \square

Corollary 3.2.15. $N \subset M$ is finite depth iff $\#\sigma(\Theta_u) < \infty$.

Due to Sato in [Sat97], $N \subset M$ is finite depth iff $P \subset R$ if finite depth. Thus the corollary follows from the previous proposition and the equivalence, $dim\{e_N, e_L\}'' < \infty \Leftrightarrow \#\sigma(\Theta_u) < \infty$. If $\{e_N, e_L\}''$ is finite dimensional then Θ_u must have a finite spectrum as $\Theta_u \in \{e_N, e_L\}''$. If Θ_u has a finite spectrum then there is a positive integer n and a polynomial $p(x)$ with degree less than n such that $\Theta_u^n = p(\Theta_u)$. This implies that $dim\{e_N, e_L\}'' < \infty$ as words in e_N and e_L of length $2n+3$ or greater can be reduced to linear combinations of words of length less than $2n+3$.

We now find a description of the angle operator on the planar algebra $\bigcup_n P_{n,+}^{Spin} \subset M$. The following lemma is a standard technique in planar algebras and C^* -tensor categories and will play an important role for computations with the angle operator.

Lemma 3.2.16 (Cable cutting). *Let $\{b_i\}_{i=1}^{Q^n} \subset P_{n,+}^{Spin}$ be an orthonormal basis of $P_{n,+}^{Spin}$ with respect to $\langle \cdot | \cdot \rangle_{Spin}$, then*

$$\left[\begin{array}{c} \$ \\ | \\ 2n \\ | \\ \$ \end{array} \right] = \sum_{i=1}^{Q^n} \left[\begin{array}{c} \$ \\ | \\ b_i \\ | \\ b_i^* \\ | \\ \$ \end{array} \right].$$

Proof. Observe that $P_{2n,+}^{Spin} \cong M_{Q^n}(\mathbb{C})$ has a faithful irreducible representation on $P_{n,+}^{Spin}$ by $x\xi = \left[\begin{array}{c} \$ \\ | \\ x \\ | \\ \xi \\ | \\ \$ \end{array} \right]$ for $x \in P_{2n,+}^{Spin}$ and $\xi \in P_{n,+}^{Spin}$. Taking $\{b_i^*\}_{i=1}^{Q^n}$ as a basis for $P_{n,+}^{Spin}$, both sides of the equality above act by the identity, hence they are equal. \square

Proposition 3.2.17. *Let $\{b_i\}_{i=1}^Q \subset P_{1,+}^{Spin}$ be an orthonormal basis, then for $x \in P_{n+1,+}^{Spin}$, E_N and E_L are given by the following diagrams:*

$$E_N(x) = \frac{1}{\sqrt{Q}} \left[\text{Diagram: A box with a vertical line on the right, a loop labeled 'x' on the left, and a top loop labeled 'n' on the right. The box is divided into two regions by the vertical line. } \right] \quad E_L(x) = \frac{1}{\sqrt{Q}} \left[\text{Diagram: A box with a vertical line on the right, a loop labeled 'x' on the left, and a top loop labeled 'n' on the right. The box is shaded gray. } \right] = \frac{1}{\sqrt{Q}} \sum_{i=1}^Q \left[\text{Diagram: A box with a vertical line on the right, a loop labeled 'x' on the left, and a top loop labeled 'n' on the right. The box is shaded gray. There are two additional loops labeled 'b_i' and 'b_i^*' on the left side. } \right]$$

Furthermore, the angle operator is given by the planar tangles

$$\Theta_u(x) = \frac{1}{\sqrt{Q}^3} \left[\text{Diagram: A box with a vertical line on the right, a loop labeled 'x' on the left, and a top loop labeled 'n' on the right. The box is divided into two regions by the vertical line. There are three concentric loops on the left side. } \right] \quad \Theta_u(\psi_u(x)) = \frac{1}{Q} \psi_u \left(\text{Diagram: A box with a vertical line on the right, a loop labeled 'x' on the left, and a top loop labeled 'n' on the right. The box is divided into two regions by the vertical line. There are two concentric loops on the left side. } \right)$$

Proof. First, $\text{tr}(x\psi_u(y)) = \text{tr}(E_N(x)\psi_u(y))$ for all $y \in \bigcup_n P_{n,+}^{Spin}$ follows from type II Reidemeister moves and the loop parameters of P^{Spin} .

$$\text{tr}(x\psi_u(y)) = \frac{1}{\sqrt{Q}^{n+1}} \left[\text{Diagram: A box with a vertical line on the right, a loop labeled 'x' on the left, and a top loop labeled 'n' on the right. The box is divided into two regions by the vertical line. There are two loops labeled 'y' and 'x' on the left side. } \right] = \frac{1}{\sqrt{Q}^{n+2}} \left[\text{Diagram: A box with a vertical line on the right, a loop labeled 'x' on the left, and a top loop labeled 'n' on the right. The box is divided into two regions by the vertical line. There are two loops labeled 'y' and 'x' on the left side. } \right] = \text{tr}(E_N(x)\psi_u(y))$$

Similarly, $\text{tr}(xy) = \text{tr}(E_L(x)y)$ for all $y \in 1 \otimes \bigcup_n P_{n,-}^{Spin}$ can be shown from the cable cutting lemma 3.2.16 and the loop parameters of P^{Spin} . Finally, the angle operator tangle follows from the tangles for E_N and E_L . \square

Definition 3.2.18. For a biunitary u define the operator $\theta_u: \bigcup_n P_{n,+}^{Spin} \rightarrow \bigcup_n P_{n,+}^{Spin}$ by the tangle

$$\theta_u(x) = \frac{1}{Q} \left[\text{Diagram: A box with a vertical line on the right, a loop labeled 'x' on the left, and a top loop labeled 'n' on the right. The box is divided into two regions by the vertical line. There are two concentric loops on the left side. } \right]$$

Since $\psi_u: L^2(N) \rightarrow L^2(M)$ is an isometry and $\Theta_u\psi_u = \psi_u\theta_u$, θ_u defines a bounded operator on $\overline{\bigcup_n P_{n,+}^{Spin}}^{\|\cdot\|_{2, \text{tr}}}$ which we will identify as $L^2(N)$.

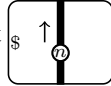
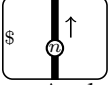
We will also use the following notation to simplify the use of biunitaries. Let  denote n parallel strings with the left most string being oriented up and alternating orientations from left to right. Similarly let  denote alternating orientations from right to left.

Applying the algebra isomorphism $Ad_{\frac{1}{\sqrt{Q}}H^*}$ yields

$$\begin{array}{ccc} \Delta_Q \subset M_Q(\mathbb{C}) & \psi_{u^*}(P_{1,+}^{Spin}) \subset P_{2,+}^{Spin} \\ \cup & \cup \cong & \cup & \cup \\ \mathbb{C} \subset H\Delta_Q H^* & \mathbb{C} & \subset P_{1,+}^{Spin} \end{array}$$

and so Θ_{u^*} is the angle operator corresponding the vertical subfactor. Since

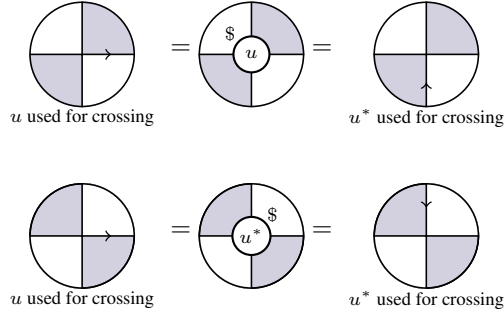

we can express Θ_{u^*} with tangles where u is used to interpret crossings. Here we have these tangles where u is used for the crossings and the middle k strings have alternating orientations

$$\Theta_{u^*}(x) = \frac{1}{\sqrt{Q^3}} \left(\text{Diagram of a vertical line with a circle 'k' at the top, a circle 'x' in the middle, and a '$' symbol on the left, with alternating orientations} \right) \quad \Theta_{u^*}(\psi_{u^*}(x)) = \frac{1}{Q} \psi_{u^*} \left(\text{Diagram of a vertical line with a circle 'k' at the top, a circle 'x' in the middle, and a '$' symbol on the left, with alternating orientations} \right) = \frac{1}{Q} \psi_{u^*}(\Theta_{u^*}(x)).$$

Proposition 3.2.19. $\sigma(\theta_u|_{P_{k,+}^{Spin}}) = \sigma(\theta_{\bar{u}}|_{P_{k,+}^{Spin}}) = \sigma(\theta_{u^T}|_{P_{k,+}^{Spin}}) = \sigma(\theta_{u^*}|_{P_{k,+}^{Spin}})$ and $\dim(P_{k,+}^u) = \dim(P_{k,+}^{\bar{u}}) = \dim(P_{k,+}^{u^T}) = \dim(P_{k,+}^{u^*})$ for all $k \in \mathbb{N}$.

Proof. Fix $k \in \mathbb{N}$ and define a conjugation on $P_{k,+}^{Spin}$ by $\bar{\xi} = \sum_{\hat{b} \in B^{\otimes k}} \bar{\xi}_{\hat{b}} \hat{b}$ where $\xi = \sum_{\hat{b} \in B^{\otimes k}} \xi_{\hat{b}} \hat{b}$, $\xi_{\hat{b}} \in \mathbb{C}$ and B is the basis used to define the action of tangles on $P_{k,+}^{Spin}$. Observe that $\overline{\theta_u(\xi)} = \theta_{\bar{u}}(\bar{\xi})$ and so the eigenvalues of $\theta_u|_{P_{k,+}^{Spin}}$ and $\theta_{\bar{u}}|_{P_{k,+}^{Spin}}$ coincide and the eigenspaces are isomorphic by conjugation.

Define

$$\phi_u(\xi) = \text{[Diagram: A square box containing a circle with a vertical line through its center. The line has a crossing with the circle. A small square labeled \xi is inside the circle, with a dollar sign \$ to its left. An arrow \gamma points clockwise around the circle.]}$$

$$\phi_u^*(\eta) = \text{[Diagram: A square box containing a circle with a vertical line through its center. The line has a crossing with the circle. A small square labeled \eta is inside the circle, with a dollar sign \$ to its left. An arrow \gamma points clockwise around the circle.]}$$

Interpreting string crossings with u^T corresponds to reversing all orientations and so

$$\theta_{u^T}(\eta) = \frac{1}{Q} \text{[Diagram: A square box containing a circle with a vertical line through its center. The line has a crossing with the circle. A small square labeled \eta is inside the circle, with a dollar sign \$ to its left. An arrow \gamma points clockwise around the circle. A small circle with a dot is above the line. Below the diagram is the text 'u used for crossings'.]}$$

If $\theta_u(\xi) = \lambda\xi$ and $\lambda \neq 0$ then $\theta_{u^T}(\phi_u(\xi)) = \phi_u(\theta_u(\xi)) = \lambda\phi_u(\xi)$. Furthermore, $\phi_u(\xi) \neq 0$ since $\phi_u^*(\phi_u(\xi)) = Q\theta_u(\xi) = Q\lambda\xi \neq 0$. This implies that $\sigma(\theta_u|_{P_{k,+}^{Spin}})$ and $\sigma(\theta_{u^T}|_{P_{k,+}^{Spin}})$ coincide and there is a bijection between eigenspaces. Therefore $\sigma(\theta_u|_{P_{k,+}^{Spin}}) = \sigma(\theta_{u^T}|_{P_{k,+}^{Spin}}) = \sigma(\theta_{u^*}|_{P_{k,+}^{Spin}})$ and $\dim(P_{k,+}^u) = \dim(P_{k,+}^{\bar{u}}) = \dim(P_{k,+}^{u^T}) = \dim(P_{k,+}^{u^*})$. \square

3.3 A Tunnel Construction for the Spin Model

The tunnel construction for subfactors is a useful tool in subfactors, however, the tunnel construction is not unique, and concretely realizing a tunnel inside $B(L^2(M))$ can be challenging for a general subfactor. We have the two $*$ -algebra homomorphisms ψ_u and φ_u which will provide a concrete realization of a tunnel construction for spin model subfactors coming from the spin planar algebra.

Observe that the planar tangles thus far have no intersections between two oriented strings. This situation leads to an ambiguity in how the tangle should be evaluated. The construction that follows requires an update to our conventions to avoid this ambiguity. Since biunitaries satisfy type *II* Reidemeister moves we will adopt the crossing conventions from knot theory. This means every intersection of strings will have an over string and under string and in general both strings will be oriented. Then the over string and its orientation will determine how we replace the crossing with a complex Hadamard matrix.

The diagram shows four equations, each representing a crossing of two oriented strings. The left side of each equation is a circle with two lines crossing. The right side is a circle divided into four quadrants by the crossing lines, with a central dot and a label. The first equation shows a crossing where the top string goes over the bottom string, with the label u . The second equation shows a crossing where the bottom string goes over the top string, with the label u . The third equation shows a crossing where the top string goes over the bottom string, with the label u^* . The fourth equation shows a crossing where the bottom string goes over the top string, with the label u^* .

With this convention we still have type *II* Reidemeister moves but we should be careful to never apply type *I* or type *III* Reidemeister moves.

Remark 3.3.1. *There are complex Hadamard matrices that allow type I Reidemeister moves. For example $\sum_x H_{i,x} = \sqrt{Q}$ for all i iff  where H is the biunitary used. In fact, a real Hadamard matrix satisfies all type I Reidemeister moves iff it is regular with ones on the diagonal (e.g. $\sum_{l=1}^Q H_{l,j} = \sum_{l=1}^Q H_{i,l} = H_{k,k} = 1$ for all i, j, k). The following 4×4 Hadamard matrix is regular and has ones on the diagonal*

$$H = \begin{pmatrix} 1 & 1 & 1 & -1 \\ 1 & 1 & -1 & 1 \\ 1 & -1 & 1 & 1 \\ -1 & 1 & 1 & 1 \end{pmatrix}.$$

Proposition 3.3.2. *Let $N = \psi_u(M) \subset M$ denote the spin model subfactor. Then*

$\psi_u(\varphi_u(M)) \subset \psi_u(M) \subset M$ and $\varphi_u(\psi_u(M)) \subset \varphi_u(M) \subset M$ are instances of the basic construction with

Jones projections $e_0 = \frac{1}{\sqrt{Q}} \left[\text{diagram of } e_0 \right] \in P_{2,+}^{Spin} \subset M$ and $f = \frac{1}{\sqrt{Q}} \left[\text{diagram of } f \right] \in P_{2,+}^{Spin} \subset M$ respectively.

Proof. Let $N_{-1} = \psi_u(\varphi_u(M))$. By the abstract characterization of the basic construction it suffices to show that $[e_0, y] = 0$ for all $y \in N_{-1}$ and $E_N(e_0) = [N : N_{-1}]^{-1} = [M : N]^{-1}$ (see [PP86]). Let $x \in P_{n,+}^{Spin}$, then by applying type II Reidemeister moves

$$\psi_u(\varphi_u(x))e_0 = \frac{1}{\sqrt{Q}} \left[\text{diagram of } \psi_u(\varphi_u(x))e_0 \right] = \frac{1}{\sqrt{Q}} \left[\text{diagram of } e_0\psi_u(\varphi_u(x)) \right] = e_0\psi_u(\varphi_u(x)).$$

Since $\bigcup_n P_{n,+}^{Spin}$ is weakly dense in M , $\psi_u\left(\varphi_u\left(\bigcup_n P_{n,+}^{Spin}\right)\right)$ is weakly dense in N_{-1} and so $[e_0, y] = 0$ for all $y \in N_{-1}$.

Observe that $[M : \varphi_u(M)] = Q$ since this subfactor comes from a spin model. Then $[M : N] = Q = [\psi_u(M) : \psi_u(\varphi_u(M))] = [N : N_{-1}]$ since ψ_u is an injective trace preserving $*$ -algebra morphism. Finally,

we can compute $E_N(e_0)$ directly.

$$E_N(e_0) = \frac{1}{Q} \left[\text{Diagram of a tunnel with two crossings} \right] = \frac{1}{Q} \cdot 1_N$$

Therefore $N_{-1} \subset N \subset M$ is a basic construction. Proving that $\varphi_u(\psi_u(M)) \subset \varphi_u(M) \subset M$ is a basic construction is identical. \square

Corollary 3.3.3. *Since $\varphi_u(\psi_u(M)) \subset \varphi_u(M) \subset M$ is a basic construction, $(\psi_u \circ \varphi_u)(N) \subset N_{-1} \subset N$ is also with the Jones projection $e_{-1} = \psi_u(f)$. Thus we have a tunnel given by $N = N_0$, $N_{-2k} = (\psi_u \circ \varphi_u)^k(N_0)$, $N_{-2k-1} = (\psi_u \circ \varphi_u)^k(N_{-1})$ with Jones projections $e_{-2k-1} = (\psi_u \circ \varphi_u)^k(e_{-1}) \in N_{-2k}$ and $e_{-2k+1} = (\psi_u \circ \varphi_u)^k(e_0) \in N_{-2k}$.*

Remark 3.3.4. *This particular tunnel for $N \subset M$ admits a planar algebra description (i.e. a grid of dense subalgebras with traces, Jones projections, and conditional expectations given by planar tangles with crossings). This is a direct consequence of ψ_u and φ_u being maps defined on the planar algebra P^{Spin} .*

Proposition 3.3.5. *Let $\Phi_{2i}^u = (\psi_u \circ \varphi_u)^i$, $\Phi_{2i+1}^u = (\psi_u \circ \varphi_u)^i \circ \psi_u$ and define $A_{-i,j} = \Phi_i^u(P_{j-i,+}^{Spin})$. Then*

$$\begin{array}{ccc} A_{1-i,j} & \subset & A_{1-i,j+1} \\ \cup & & \cup \\ A_{-i,j} & \subset & A_{-i,j+1} \end{array} \text{ is a symmetric commuting square for } j \geq i \geq 0 \text{ with respect to the traces induced by } tr_M.$$

Proof. Since both $\begin{array}{ccc} P_{n,+}^{Spin} & \subset & P_{n+1,+}^{Spin} \\ \cup & & \cup \end{array}$ and $\begin{array}{ccc} P_{n,+}^{Spin} & \subset & P_{n+1,+}^{Spin} \\ \cup & & \cup \end{array}$ are symmetric com-

muting squares, so are all their images under repeated application of the trace-preserving *-isomorphisms ψ_u

$$\begin{array}{ccc} A_{1-i,j} & \subset & A_{1-i,j+1} \\ \cup & & \cup \end{array} \text{ and } \varphi_u. \text{ Every square of algebras } \begin{array}{ccc} A_{-i,j} & \subset & A_{-i,j+1} \\ \cup & & \cup \end{array} \text{ is obtained this way. } \square$$

Corollary 3.3.6. *We have the following grid of symmetric commuting squares that generate the tunnel for*

$N \subset M$ defined above.

$$\begin{array}{cccccccc}
 \mathbb{C} = A_{0,0} & \subset & A_{0,1} & \subset & A_{0,2} & \subset & A_{0,3} & \subset \cdots \subset M \\
 & & \cup & & \cup & & \cup & & \cup \\
 & & \mathbb{C} = A_{-1,1} & \subset & A_{-1,2} & \subset & A_{-1,3} & \subset \cdots \subset N \\
 & & & & \cup & & \cup & & \cup \\
 & & & & \mathbb{C} = A_{-2,2} & \subset & A_{-2,3} & \subset \cdots \subset N_{-1} \\
 & & & & & & \ddots & & \vdots
 \end{array}$$

Furthermore, the Jones projections for the tunnel belong to the following algebras $e_{-n} \in A_{-n, n+2}$ for $n \geq 0$.

Alternatively, $A_{-n, m}$ can be obtained from $A_{-n, m} = \{e_{2-n}\}' \cap A_{1-n, m}$.

CHAPTER 4

Symmetric Enveloping Algebras

The symmetric enveloping algebra construction associated to a subfactor with finite Jones index $N \subset M$ is due to Popa and is denoted by $S = M \underset{e_N}{\boxtimes} M^{op}$ (see [Pop94a] and [Pop99]). Let M^{op} be the von Neumann algebra with the underlying vector space M , multiplication $a \cdot^{op} b = ba$ and the usual adjoint. S is the unique II_1 factor generated by commuting copies of M and M^{op} along with e_N such that $M' \cap S = M^{op}$, $(M^{op})' \cap S = M$ and e_N implements the conditional expectations for both $N \subset M$ and $N^{op} \subset M^{op}$. For this construction $N \subset M$ must be finite index and extremal since we must have a coherent trace on $M' \cap M_k \cong M^{op} \cap M_k \subset S$. For more information see [Pop94a] and [Pop99].

An important algebra to keep in mind during this construction is $C^*(M, e_N, JMJ) \subset B(L^2(M))$. Observe that $C^*(M, e_N, JMJ)$ has the following properties (see [Pop99]):

- (1) There are unital $*$ -embeddings $j: \langle M, e_N \rangle \rightarrow C^*(M, e_N, JMJ)$,
 $j^{op}: \langle M, e_N \rangle^{op} \rightarrow C^*(M, e_N, JMJ)$ such that $[j(M), j^{op}(M^{op})] = 0$ and $j(e_N) = j^{op}(e_N)$.
- (2) $C^*(M, e_N, JMJ)$ is generated by $j(M)$, $j(e_N)$ and $j^{op}(M^{op})$ as a C^* -algebra inside $B(L^2(M))$.
- (3) There is a faithful representation $\pi: C^*(M, e_N, JMJ) \rightarrow B(L^2 M)$ such that $j(M)$ and $j^{op}(M^{op})$ are represented as von Neumann algebras.
- (4) $j(M)' \cap C^*(M, e_N, M^{op}) = j^{op}(M^{op})$ and $(j^{op}(M^{op}))' \cap C^*(M, e_N, M^{op}) = j(M)$.
- (5) There is an anti-isomorphism $x \mapsto x^{op}$ given by Jx^*J .

Let S_0 denote a C^* -algebra satisfying properties (1) – (3). We will now outline the symmetric enveloping algebra construction given in [Pop99].

Lemma 4.0.1. [Pop99] *Let j , j^{op} and S_0 be as above. Then j and j^{op} extend to unital $*$ -embeddings $j: \bigcup_k M_k \rightarrow S_0$ and $j^{op}: \bigcup_k M_k^{op} \rightarrow S_0$.*

Proof. Let $\cdots N_{-k} \subset \cdots \subset N_{-1} \subset N_0 = N \subset M_0 = M \subset M_1$ be a tunnel construction for $N \subset M$ with Jones projections $e_{-k} \in N_{1-k}$, $e_0 \in M$ and $e_1 = e_N$. Then by the abstract characterization of the basic construction $M_k \cong \{j(M), j(e_1), j^{op}(e_0^{op}), \dots, j^{op}(e_{2-k}^{op})\}''$. Thus we may extend j by setting $j(e_{k+2}) = j^{op}(e_{-k}^{op})$. However, this extension depends on the choice of the tunnel. We may extend j^{op} in an identical way, and so there exist unital $*$ -embeddings $j: \bigcup_k M_k \rightarrow S_0$ and $j^{op}: \bigcup_k M_k^{op} \rightarrow S_0$. \square

Lemma 4.0.2. [Pop99] Let j , j^{op} and S_0 be as above. Then

$$\begin{aligned} \text{Alg}(j(M_1), j^{op}(M_1^{op})) &= \bigcup_k \text{span } j^{op}(M^{op})j(M_k)j^{op}(M^{op}) = \bigcup_k \text{span } j(M)j^{op}(M_k^{op})j(M) \\ &= \bigcup_k \text{span } j(M)j^{op}(M^{op})j(f_{-k}^k)j(M)j^{op}(M^{op}) \end{aligned}$$

where f_{-k}^k is the Jones projection for $N_{1-k} \subset M \subset M_k$.

Proof. Observe that f_{-k}^k is a scalar multiple of the longest word in e_{2-k}, \dots, e_k and so $j(f_{-k}^k) = j^{op}((f_{-k}^k)^{op})$ since $j(e_{k+2}) = j^{op}(e_{-k}^{op})$. Since the last equality contains $j(M_1)$ and $j^{op}(M_1^{op})$ it suffices to show that $\bigcup_k \text{span } j(M)j^{op}(M^{op})j(f_{-k}^k)j(M)j^{op}(M^{op})$ is an algebra.

Let f_{-2k}^0 and f_0^{2k} be the Jones projections for $N_{1-2k} \subset N_{1-k} \subset M$ and $M \subset M_k \subset M_{2k}$ respectively.

Then

$$\begin{aligned} &j(f_{-k}^k)j(M)j^{op}(M^{op})j(f_{-k}^k) \\ &\subset \text{span } j(N_{1-k})j(f_{-k}^k)j(f_{-2k}^0)j(N_{1-k})j^{op}(N_{1-k}^{op})j^{op}((f_{-2k}^0)^{op})j(f_{-k}^k)j^{op}(N_{1-k}^{op}) \\ &\subset \text{span } j(N_{1-k})j^{op}(N_{1-k}^{op})j(f_{-k}^k)j(f_{-2k}^0)j^{op}((f_{-2k}^0)^{op})j(f_{-k}^k)j(N_{1-k})j^{op}(N_{1-k}^{op}) \\ &\subset \text{span } j(N_{1-k})j^{op}(N_{1-k}^{op})j(f_{-2k}^{2k})j(N_{1-k})j^{op}(N_{1-k}^{op}). \end{aligned}$$

Therefore $\bigcup_k \text{span } j(M)j^{op}(M^{op})j(f_{-k}^k)j(M)j^{op}(M^{op})$ is an algebra. \square

For the following lemma, let the tunnel for $N \subset M$ be indexed by $N_{-k} = M_{-k-1}$.

Lemma 4.0.3. [Pop99] Let j , j^{op} and S_0 be as above and suppose that S_0 satisfies the **smoothness condition**

$$j(M' \cap M_k) \subset j^{op}(M^{op}) \text{ for all } k \geq 1.$$

Then $j(M_k)' \cap S_0 = j^{op}(M_{-k}^{op})$, $j^{op}(M_k^{op})' \cap S_0 = j(M_{-k})$ and $j(M_i' \cap M_j) = j(M_i) \cap j(M_j) = j^{op}(M_{-i}^{op}) \cap j^{op}(M_{-j}^{op})'$. Furthermore there exist unique conditional expectations $\mathcal{E}_i^+ : S_0 \rightarrow j(M_i)' \cap S_0$ and $\mathcal{E}_i^- : S_0 \rightarrow j^{op}(M_i^{op})' \cap S_0$ with the following properties:

- (i) $\mathcal{E}_i^+(j(x)) = j(E_{M_i' \cap M_k}(x))$ and $\mathcal{E}_i^-(j^{op}(x^{op})) = j^{op}(E_{M_i' \cap M_k}(x^{op}))$ for all $x \in M_k$.
- (ii) $\mathcal{E}_i^+ \circ \text{Ad}_{j(u)} = \mathcal{E}_i^+$ and $\mathcal{E}_i^- \circ \text{Ad}_{j^{op}(u^{op})} = \mathcal{E}_i^-$ for all $u \in \mathcal{U}(M_i)$.

Theorem 4.0.4. [Pop99] Let S_0 be as above and suppose that it satisfies the previous lemma. Then there exists a unique tracial state τ on S_0 and the trace ideal, \mathcal{I}_τ , is the unique maximal ideal of S_0 . Furthermore, this trace is given by $\tau = \text{tr}_M \circ \mathcal{E}_1^- = \text{tr}_{M'} \circ \mathcal{E}_1^+$.

Remark 4.0.5. A universal C^* -algebra \mathcal{U}_0 satisfying (1) – (3) and the smoothness condition can be constructed and so every S_0 satisfying these conditions embeds into this \mathcal{U}_0 . This implies the uniqueness of the simple C^* -algebra S_0/\mathcal{I}_τ . Then doing the GNS construction with τ we obtain the II_1 factor $M \boxtimes_{e_N} M^{op} = S = \pi_\tau(S_0/\mathcal{I}_\tau)''$. We also have an anti-automorphism on S denoted by $x \mapsto x^{op}$ which comes from the anti-automorphism op on $\text{Alg}(j(M), j(e_N), j^{op}(M^{op}))$.

Definition 4.0.6. [Pop99] We call $M \boxtimes_{e_N} M^{op}$ the **symmetric enveloping** II_1 factor associated with $N \subset M$ and the subfactor $M \vee M^{op} \subset M \boxtimes_{e_N} M^{op}$ is the **symmetric enveloping inclusion** where $M \vee M^{op}$ is the von Neumann algebra generated by M and M^{op} inside $M \boxtimes_{e_N} M^{op}$.

We will now summarize some important results regarding the symmetric enveloping inclusion.

Proposition 4.0.7. [Pop99] An extremal finite index subfactor $N \subset M$ has finite depth iff the symmetric enveloping inclusion has finite index. Moreover if these conditions are satisfied then $M \vee M^{op} \subset M \boxtimes_{e_N} M^{op}$ is finite depth and has index $\sum_{M X_M} (\dim_M X_M)^2$ where the summation is over all irreducible M - M bimodules arising from $N \subset M$.

Theorem 4.0.8. [Pop94a] An extremal hyperfinite subfactor $N \subset M$ is amenable iff $\|\Gamma\|^2 = [M : N]$ where Γ is the principal graph of $N \subset M$.

There are several equivalent notions of amenability for subfactors or their standard invariants due to Popa (see [Pop94a],[Pop94b]).

Theorem 4.0.9. [Pop99] Let $N \subset M$ be a finite index extremal subfactor. The following conditions are equivalent:

- (i) $N \subset M$ is amenable.
- (ii) $M \boxtimes_{e_N} M^{op}$ is hyperfinite.
- (iii) $C^*(M, e_N, JMJ)$ is simple.
- (iv) Let \mathcal{U} be a C^* algebra with embeddings of M_1 and M_1^{op} satisfying conditions (1) – (3) and the smoothness condition. Then the corresponding trace ideal, \mathcal{I}_τ , is trivial.

4.1 Computation of $\tau(\Theta_u^n)$

We now apply Popa's symmetric enveloping algebra to the spin model. The existence and faithfulness of the trace τ on $C^*(M, e_N, JMJ)$ for amenable subfactors plays a key role in this section. We will show that the spectra of θ_u and $\Gamma\Gamma^*$ coincide when $N \subset M$ is an amenable subfactor in the sense of [Pop94b], where Γ denotes the principal graph of $N \subset M$ written as a $V(\Gamma_{\text{even}}) \times V(\Gamma_{\text{odd}})$ matrix. Note that in [KS99], Kodyalam and Sunder showed that $\begin{bmatrix} 0 & \Gamma \\ \Gamma^* & 0 \end{bmatrix}$ and $\begin{bmatrix} 0 & \Lambda \\ \Lambda^* & 0 \end{bmatrix}$ have the same spectrum with zero as the only possible exception where Λ is the dual graph.

We will first define a collection of operators in $C^*(M, e_N, JMJ)$ using the planar algebra formalism. Then we will use this formalism to compute the value of τ on these operators. These operators will be defined on the dense subspace of $L^2(M)$ given by $\bigcup_k P_{k,+}^{\text{Spin}}$ then extended uniquely by continuity. Vectors $\xi \in \bigcup_k P_{k,+}^{\text{Spin}}$ will be arranged with their marked intervals on the right and strings at the left. Then the actions of $x \in P_{n,+}^{\text{Spin}} \subset M$, $Jy^*J \in JP_{n,+}^{\text{Spin}}J \subset JMJ$, and e_N on $\xi \in P_{n+k,+}^{\text{Spin}}$ are given by

$$x\xi = \begin{array}{c} \text{\$} \text{\$} \\ \text{\$} \text{\$} \\ \text{\$} \text{\$} \\ \text{\$} \text{\$} \\ \text{\$} \text{\$} \\ \text{\$} \text{\$} \\ \text{\$} \text{\$} \\ \text{\$} \text{\$} \\ \xi \text{\$} \end{array} \quad Jy^*J\xi = \begin{array}{c} \text{\$} \\ \text{\$} \\ \text{\$} \\ \text{\$} \\ \text{\$} \\ \text{\$} \\ \text{\$} \\ \text{\$} \\ \text{\$} \\ \text{\$} \\ \xi \text{\$} \end{array} \quad e_N\xi = \frac{1}{\sqrt{Q}} \begin{array}{c} \text{\$} \\ \text{\$} \\ \text{\$} \\ \text{\$} \\ \text{\$} \\ \text{\$} \\ \text{\$} \\ \text{\$} \\ \xi \text{\$} \end{array}.$$

Definition 4.1.1. Fix n , let $x, y \in P_{n,+}^{\text{Spin}}$ and define the linear operator $\pi_{x,y} : \bigcup_k P_{k,+}^{\text{Spin}} \rightarrow \bigcup_k P_{k,+}^{\text{Spin}}$

$$\pi_{x,y}\xi = \begin{array}{c} \text{\$} \text{\$} \\ \text{\$} \text{\$} \\ \text{\$} \text{\$} \\ \text{\$} \text{\$} \\ \text{\$} \text{\$} \\ \text{\$} \text{\$} \\ \text{\$} \text{\$} \\ \text{\$} \text{\$} \\ \xi \text{\$} \end{array} \quad \text{for } \xi \in P_{k+1,+}^{\text{Spin}}.$$

This is well defined since $\pi_{x,y}$ commutes with the inclusion maps $i_k(\xi) = \begin{array}{c} \text{\$} \text{\$} \\ \text{\$} \text{\$} \\ \text{\$} \text{\$} \\ \xi \text{\$} \end{array}$ by type II Reidemeister moves.

Proposition 4.1.2. The linear operators $\pi_{x,y}$ for $x, y \in P_{n,+}^{\text{Spin}}$ extend uniquely to bounded operators on $L^2(M)$ also denoted by $\pi_{x,y}$. Furthermore, these bounded operators belong to $C^*(M, e_N, JMJ)$.

Proof. Let $\{b_i\}_{i=1}^Q$ be an orthonormal basis of $P_{1,+}^{Spin}$. Then

$$Qe_N b_i J b_j J e_N \xi = \pi_{b_i, b_j} \xi = \text{for } \xi \in P_{k+1,+}^{Spin}$$

and so $\pi_{b_i, b_j} \in C^*(M, e_N, JMJ)$. Let i_1, i_2, \dots, i_n and j_1, j_2, \dots, j_n be indices taking values in $\{1, 2, \dots, Q\}$ then

$$Q^{\frac{n-1}{2}} \pi_{b_{i_1}, b_{j_1}} \pi_{b_{i_2}, b_{j_2}} \cdots \pi_{b_{i_n}, b_{j_n}} \xi = \pi_{x, y} \xi = \text{for } \xi \in P_{k+1,+}^{Spin}$$

where $x = \begin{matrix} \text{\$} & \text{\$} & & \text{\$} \\ \text{\$} & \text{\$} & \cdots & \text{\$} \\ \text{\$} & \text{\$} & & \text{\$} \\ \text{\$} & \text{\$} & & \text{\$} \end{matrix} \begin{matrix} b_{i_1} \\ b_{i_2} \\ \cdots \\ b_{i_n} \end{matrix}$ and $y = \begin{matrix} \text{\$} & \text{\$} & & \text{\$} \\ \text{\$} & \text{\$} & \cdots & \text{\$} \\ \text{\$} & \text{\$} & & \text{\$} \\ \text{\$} & \text{\$} & & \text{\$} \end{matrix} \begin{matrix} b_{j_1} \\ b_{j_2} \\ \cdots \\ b_{j_n} \end{matrix}$.

Since elements of the same form as x for different indices i_1, \dots, i_n form an orthogonal basis of $P_{n,+}^{Spin}$, we obtain $\pi_{x, y} \in C^*(M, e_N, JMJ)$ for any $x, y \in P_{n,+}^{Spin}$. \square

Lemma 4.1.3. Fix $n, l \in \mathbb{N}$ and let $x, y \in P_{n,+}^{Spin}$. Define the linear operator $\rho_{x, y, l}: \bigcup_k P_{k+2l,+}^{Spin} \rightarrow \bigcup_k P_{k+2l,+}^{Spin}$

$$\rho_{x, y, l} \xi = \text{for } \xi \in P_{k+2l+1,+}^{Spin}$$

Then $\rho_{x, y, l}$ extends uniquely to a bounded operator on $L^2(M)$ with

$$\|\rho_{x, y, l}\|_{B(L^2(M))} \leq \sqrt{Q} \|x\|_{Spin} \|y\|_{Spin}.$$

Proof. We will verify this inequality by obtaining an upper bound of $|\langle \rho_{x, y, l} \xi | \eta \rangle_{trM}|$ for ξ and η in a dense subset of $L^2(M)$. Let $\xi, \eta \in P_{k+2l+1,+}^{Spin}$, then due to the Cauchy-Schwarz inequality and unitarity of the first diagram below

$$\begin{aligned}
|\langle \rho_{x,y,l} \xi \mid \eta \rangle_{Spin}| &= \left| \left(\begin{array}{c} \text{Diagram 1} \\ \text{Diagram 2} \\ \text{Diagram 3} \end{array} \right) \right|_{Spin} \\
&\leq \left(\begin{array}{c} \text{Diagram 4} \\ \text{Diagram 5} \end{array} \right)^{1/2} \leq \sqrt{Q} \|x\|_{Spin} \|y\|_{Spin} \|\xi\|_{Spin} \|\eta\|_{Spin}.
\end{aligned}$$

Since the tracial inner product is a normalization of $\langle \cdot \mid \cdot \rangle_{Spin}$, we have

$$|\langle \rho_{x,y,l} \xi \mid \eta \rangle_{tr_M}| \leq \|x\|_{Spin} \|y\|_{Spin} \|\xi\|_{tr_M} \|\eta\|_{tr_M}$$

for all ξ, η in a dense subset of $L^2(M)$. Therefore $\rho_{x,y,l}$ extends uniquely to a bounded operator with $\|\rho_{x,y,l}\|_{B(L^2(M))} \leq \sqrt{Q} \|x\|_{Spin} \|y\|_{Spin}$. \square

Lemma 4.1.4. Let $\{b_i\}_{i=1}^{Q^n}$ be an orthonormal basis of $P_{n,+}^{Spin}$ with respect to $\langle \cdot \mid \cdot \rangle_{Spin}$, then $\sum_{i=1}^{Q^n} b_i b_i^* = \sqrt{Q}^n \cdot id_{P_{n,+}^{Spin}}$.

This lemma follows from the cable cutting lemma 3.2.16 and the loop parameters for P^{Spin} .

Proposition 4.1.5. Let τ denote the unique continuous trace on $C^*(M, e_N, JMJ)$ constructed in [Pop99]. Then for $x, y \in P_{n,+}^{Spin}$ and any $l \in \mathbb{N}$

$$|\tau(\pi_{x,y})| \leq \frac{1}{\sqrt{Q}} \|\theta_{u^*}^l(x)\|_{Spin} \|\theta_{u^*}^l(y)\|_{Spin}.$$

Proof. Let $\{b_i\}_{i=1}^{Q^{2l+1}}$ be an orthonormal basis of $P_{2l+1,+}^{Spin}$. Since τ is a trace

$\tau(\pi_{x,y}) = \sum_{i,j=1}^{Q^{2l+1}} \frac{1}{\sqrt{Q^{4l+2}}} \tau(b_i J b_j^* J \pi_{x,y} b_i^* J b_j J)$. Let $\xi \in \cup_k P_{2l+k+1,+}^{Spin}$ then

$$\sum_{i,j=1}^{Q^{2l+1}} \frac{1}{\sqrt{Q^{4l+2}}} b_i J b_j^* J \pi_{x,y} b_i^* J b_j J \xi = \sum_{i,j=1}^{Q^{2l+1}} \frac{1}{\sqrt{Q^{4l+2}}} \xi$$

$$= \frac{1}{\sqrt{Q^{4l+2}}} \xi = \frac{1}{Q} \rho_{\theta_u^l(x), \theta_u^l(y), l}$$

Since τ is norm continuous and using Lemma 5.4.2, the proposition follows. \square

Proposition 4.1.6. $\tau(\Theta_u^n) = \frac{\dim(N' \cap M_{n-1})}{Q^{n+1}}$ for $n \geq 1$.

Proof. Let $\{b_i\}_{i=1}^Q$ be an orthonormal basis of $P_{1,+}^{Spin}$ then by Proposition 3.2.17

$$\Theta_u \xi = \frac{1}{\sqrt{Q^3}} \xi = \frac{1}{\sqrt{Q^3}} \sum_{i=1}^Q \pi_{b_i, b_i} \xi \quad \text{for } \xi \in P_{k+1,+}^{Spin}$$

and so $\Theta_u \in C^*(M, e_N, JMJ)$ and $\tau(\Theta_u^n)$ is well-defined. Similarly, if $\{b_i\}_{i=1}^{Q^n}$ is an orthonormal basis of $P_{n,+}^{Spin}$ then

$$\Theta_u^n \xi = \frac{1}{Q^{n+1/2}} \xi = \frac{1}{Q^{n+1/2}} \sum_{i=1}^{Q^n} \pi_{b_i, b_i} \xi \quad \text{for } \xi \in P_{k+1,+}^{Spin}$$

Let $d_n = \dim(P_{n,+}^{u*})$ and choose an orthonormal basis, $\{f_i\}_{i=1}^{d_n}$ of $P_{n,+}^{u*}$ and an orthonormal basis, $\{b_j\}_{j=1}^{Q^n - d_n}$ of $(P_{n,+}^{u*})^\perp \cap P_{n,+}^{Spin}$. Since the f_i 's are flat, $\pi_{f_i, f_i} = \sqrt{Q} \langle f_i | f_i \rangle_{Spin} e_N = \sqrt{Q} e_N$ and so

$$\tau(\Theta_u^n) = \frac{1}{Q^{n+1/2}} \sum_{i=1}^{d_n} \tau(\pi_{f_i, f_i}) + \frac{1}{Q^{n+1/2}} \sum_{j=1}^{Q^n - d_n} \tau(\pi_{b_j, b_j}) = \frac{\dim(N' \cap M_{n-1})}{Q^{n+1}} + \frac{1}{Q^{n+1/2}} \sum_{j=1}^{Q^n - d_n} \tau(\pi_{b_j, b_j}).$$

It suffices to show that $\tau(\pi_{b_j, b_j}) = 0$. By Proposition 4.1.5 $|\tau(\pi_{b_j, b_j})| \leq \|\theta_{u^*}^l(b_j)\|_{Spin}^2$ for any $l \in \mathbb{N}$. Since the b_j 's are orthogonal to the eigenspace of θ_{u^*} corresponding to the eigenvalue $\lambda = 1$ and $\theta_{u^*}|_{P_{n,+}^{Spin}}$ is a positive, diagonalizable operator with norm less than or equal to one, $\|\theta_{u^*}^l(b_j)\|_{Spin} \leq (1 - \varepsilon)^l$ for some $0 < \varepsilon < 1$. Therefore $\tau(\pi_{b_j, b_j}) = 0$. \square

Theorem 4.1.7. $\sigma(\Gamma\Gamma^*) \subset \overline{\bigcup_n \sigma(Q\theta_u|_{P_{n,+}^{Spin}})}$ with equality iff $N \subset M$ is amenable where Γ is the principal graph of $N \subset M$.

Proof. Observe that $\Theta_u = e_N \Theta_u e_N$ and so Θ_u belongs to the corner algebra $e_N C^*(M, e_N, JMJ) e_N$ which is faithfully represented on $e_N L^2(M)$. Using the unitary, $\psi_u : L^2(N) \rightarrow e_N L^2(M)$, defined in Proposition 3.1.5, we may represent $e_N C^*(M, e_N, JMJ) e_N$ on $L^2(N)$ by $\lambda : e_N C^*(M, e_N, JMJ) e_N \rightarrow B(L^2(N))$, $\lambda(x)\xi = \psi_u^* x \psi_u \xi$. Set $\mathcal{S} = \lambda(e_N C^*(M, e_N, JMJ) e_N) \subset B(L^2(N))$ and define a tracial state $\tilde{\tau} : \mathcal{S} \rightarrow \mathbb{C}$, $\tilde{\tau}(x) = Q\tau(\psi_u x \psi_u^*)$. Since $\psi_u \psi_u^* = e_N$, $\Theta_u \psi_u = \psi_u \theta_u$, and $\tau(e_N) = \text{tr}_{M_1}(e_N) = \frac{1}{Q}$ then $\theta_u \in \mathcal{S}$ and $\tilde{\tau}$ is a normalized trace with $\tilde{\tau}(\theta_u^n) = \frac{\dim(N' \cap M_{n-1})}{Q^n}$ for all $n \geq 0$.

Let Γ be the principal graph of $N \subset M$. $\Gamma\Gamma^*$ defines a bounded linear operator in $B(L^2(V(\Gamma_{even})))$ where $L^2(V(\Gamma_{even}))$ has the even vertices as an orthonormal basis. $C^*(1, \Gamma\Gamma^*)$ comes with a state $\phi(x) = \langle x\delta_* | \delta_* \rangle$ where δ_* is the indicator function on the distinguished vertex of Γ . Frobenius reciprocity in the fusion algebra of $N \subset M$ implies that ϕ is faithful (see [KS99]). By the Riesz-Markov-Kakutani representation theorem, ϕ (resp. $\tilde{\tau}$) induce unique positive Radon measures, $d\phi$ (resp. $d\tilde{\tau}$) on the spectrum of $\Gamma\Gamma^*$ (resp. $Q\theta_u$). Since these spectra are compact subsets of $[0, Q]$, we may consider $d\phi$ (resp. $d\tilde{\tau}$) as positive Radon measures on $[0, Q]$ by $d\phi(E) = d\phi(E \cap \sigma(\Gamma\Gamma^*))$ (resp. for $d\tilde{\tau}$). Since $\phi((\Gamma\Gamma^*)^n) = \dim(N' \cap M_{n-1})$, the moments of $d\phi$ and $d\tilde{\tau}$ are equal,

$$\int_0^Q \lambda^n d\phi(\lambda) = \int_0^Q \lambda^n d\tilde{\tau}(\lambda) \quad \text{for all } n \geq 0$$

and so by the Stone-Weierstrass theorem these measures define the same continuous linear functionals on

$C([0, Q])$. Then by faithfulness of ϕ

$$\sigma(\Gamma^*) = \text{supp}(d\phi) = \text{supp}(d\tilde{\tau}) \subset \sigma(Q\theta_u).$$

If $N \subset M$ is amenable then, due to Popa, $\tilde{\tau}$ is also faithful yielding equality of the spectra. If $N \subset M$ is not amenable then $\|\Gamma\|^2 < \|Q\theta_u\| = Q$ and so their spectra cannot be equal. $\sigma(Q\theta_u) = \overline{\bigcup_n \sigma(Q\theta_u|_{P_{n,+}^{Spin}})}$ remains to be shown.

$\overline{\bigcup_n \sigma(Q\theta_u|_{P_{n,+}^{Spin}})} \subset \sigma(Q\theta_u)$ is trivially true. Now let $r \notin \sigma(Q\theta_u)$ and observe that $\left\| \frac{1}{r - Q\theta_u} \right\| \leq \frac{1}{\text{dist}(r, \sigma(Q\theta_u))}$ by continuous functional calculus. Since $r - Q\theta_u$ maps $P_{n,+}^{Spin}$ bijectively onto $P_{n,+}^{Spin}$, then $\left\| \frac{1}{(r - Q\theta_u)|_{P_{n,+}^{Spin}}} \right\| \leq \left\| \frac{1}{r - Q\theta_u} \right\|$. Since $Q\theta_u|_{P_{n,+}^{Spin}}$ is diagonalizable, $r \notin \overline{\bigcup_n \sigma(Q\theta_u|_{P_{n,+}^{Spin}})}$, and so $\sigma(\Gamma^*) = \bigcup_n \sigma(Q\theta_u|_{P_{n,+}^{Spin}})$. \square

This provides us with two computational tools. First, if we already know a spin model subfactor is amenable then we can compute elements in the spectrum of its principal graph. Second, since the spectrum of a finite graph is contained in the algebraic integers, we may prove that a spin model subfactor is infinite depth by finding non-algebraic integers in the spectrum of $Q\theta_u$.

4.2 Infinite depth spin model subfactors

First, we consider continuous families of complex Hadamard matrices, u_t . Such a family yields a continuous family of angle operators $\theta_{u_t}|_{P_{n,+}^{Spin}}$ for each $n \geq 0$. This will imply that infinite depth subfactors are a generic feature of continuous families of complex Hadamards. For a von Neumann algebra, A , let $(A)_1$ denote the unit ball and let

$$D(A, B) = \sup \left\{ \inf_{x \in (B)_1} \|a - x\|, \inf_{x \in (A)_1} \|b - x\| \mid a \in (A)_1 \text{ and } b \in (B)_1 \right\}$$

denote the Hausdorff metric between two von Neumann algebras, $A, B \subset B(H)$. Then in [Phi74], Phillips shows that if $D(A, B) < \varepsilon (\leq \frac{1}{12})$ then $Z(A) \cong Z(B)$. The isomorphism $\varphi: Z(A) \rightarrow Z(B)$ is given by $\varphi(p) = q$ where q is the unique central projection in B such that $\|p - q\| < \frac{1}{3}$. Furthermore, if $D(A, B) < \frac{1}{25618}$ and A is a type I von Neumann algebra then A and B are unitarily equivalent. See also [Chr79] for similar results for type II_1 von Neumann algebras using the trace norm instead of the operator norm.

Lemma 4.2.1. *Let $A_0 \subset A_1 \subset A_2 \subset B(H)$ and $B_0 \subset B_1 \subset B_2 \subset B(H)$ be finite dimensional C^* -*

algebras with unital inclusions. Suppose there exists a projection $e \in A_2 \cap B_2$ implementing the unique conditional expectations $E_{A_0}^{A_1}$ and $E_{B_0}^{B_1}$ with respect to their Markov traces. Further assume that $A_2 = \{A_1, e\}''$, $B_2 = \{B_1, e\}''$ and that $D(A_i, B_i) < \frac{1}{265180}$ for $i = 0, 1, 2$. Then the bijection between minimal central projections above induces an isomorphism between $\Gamma^{A_i \subset A_{i+1}}$ and $\Gamma^{B_i \subset B_{i+1}}$ and commutes with the map $p \mapsto pe$ for $p \in Z(A_0)$, sending p to a minimal central projection in A_2 .

Proof. Observe that the inclusion matrix for $A_0 \subset A_1$, is given by $\Gamma^{A_0 \subset A_1} = (\gamma_{p,q})_{p,q \text{ min. central proj.}}$ where $\gamma_{p,q} = 0$ if $pq = 0$ and $\gamma_{p,q} = \sqrt{\frac{\dim(pqA_1pq)}{\dim(pqA_0pq)}}$ otherwise. Thus, if $D(A_0, B_0)$ and $D(A_1, B_1)$ are sufficiently small then the centers of A_i and B_i can be identified. Furthermore,

$D(pqA_i pq, \varphi(pq)B_i \varphi(pq)) < \frac{1}{25618}$ for any $p \in Z(A_0)$ and $q \in Z(A_1)$. This implies that the inclusion matrices for $A_0 \subset A_1$ and $B_0 \subset B_1$ are isomorphic. The same argument applies to the other inclusions.

The last claim follows from the observation $\|pe - \varphi(p)e\| \leq \|p - \varphi(p)\| < \frac{1}{3}$. \square

Proposition 4.2.2. *Let $H: \mathbb{R} \rightarrow M_Q(\mathbb{C})$, $t \mapsto H_t$, be a continuous family of complex Hadamard matrices. Then one of the following is true:*

1. *The corresponding principal graphs are equal for all $t \in \mathbb{R}$.*
2. *There are uncountably many $t \in \mathbb{R}$ such that the corresponding subfactors are infinite depth.*

Proof. Given $t \mapsto H_t$, let $t \mapsto u_t$ be the corresponding biunitaries. Then for all fixed $n \geq 0$, $t \mapsto Q\theta_{u_t}|_{P_{n,+}^{Spin}}$ is a continuous map to positive finite dimensional matrices. Since the spectra of positive matrices vary continuously in the Hausdorff metric, if $t \mapsto \sigma(Q\theta_{u_t}|_{P_{n,+}^{Spin}})$ is not constant then uncountably many t yield infinite depth subfactors.

Now suppose that $t \mapsto \sigma(Q\theta_{u_t}|_{P_{n,+}^{Spin}})$ is constant for all $n \geq 0$. Since the spectrum is constant and $\sigma(\theta_{u_t}|_{P_{n,+}^{Spin}}) = \sigma(\theta_{u_t^*}|_{P_{n,+}^{Spin}})$, the 1-eigenspaces, $P_{n,+}^{u_t^*} \subset P_{n,+}^{Spin}$, vary continuously in the metric $D(A, B)$ defined above. Letting $N_t \subset M_t$ denote the spin model subfactor from u_t , the previous lemma implies that

$$S_{s,n} = \{t \in \mathbb{R} \mid \Gamma^{N_t \subset M_t} \text{ is isomorphic up to depth } n \text{ to } \Gamma^{N_s \subset M_s}\}$$

is an open subset of \mathbb{R} for all n . By connectedness $S_{s,n} = \mathbb{R}$ for all n and so (1) is true. \square

Example 4.2.3. *In [Pet97] Petrescu constructs a continuous family of inequivalent 7×7 complex Hadamard*

matrices given by

$$H = \begin{bmatrix} \lambda\omega & \lambda\omega^4 & \omega^5 & \omega^3 & \omega^3 & \omega & 1 \\ \lambda\omega^4 & \lambda\omega & \omega^3 & \omega^5 & \omega^3 & \omega & 1 \\ \omega^5 & \omega^3 & \bar{\lambda}\omega & \bar{\lambda}\omega^4 & \omega & \omega^3 & 1 \\ \omega^3 & \omega^5 & \bar{\lambda}\omega^4 & \bar{\lambda}\omega & \omega & \omega^3 & 1 \\ \omega^3 & \omega^3 & \omega & \omega & \omega^4 & \omega^5 & 1 \\ \omega & \omega & \omega^3 & \omega^3 & \omega^5 & \omega^4 & 1 \\ 1 & 1 & 1 & 1 & 1 & 1 & 1 \end{bmatrix}$$

where $\omega = e^{i\pi/3}$ and $\lambda \in \mathbb{T}$. Letting u be the corresponding biunitary in P^{Spin} , $7\theta_u|_{P_{2,+}^{Spin}}$ has an eigenvector given by

$$\xi = \begin{bmatrix} 0 & 0 & 1 & -1 & \frac{1}{\sqrt{3}}Im(\lambda\bar{\omega}) & \frac{-1}{\sqrt{3}}Im(\lambda) & \frac{1}{\sqrt{3}}Im(\lambda\omega) \\ 0 & 0 & -1 & 1 & \frac{1}{\sqrt{3}}Im(\lambda\bar{\omega}) & \frac{-1}{\sqrt{3}}Im(\lambda) & \frac{1}{\sqrt{3}}Im(\lambda\omega) \\ 1 & -1 & 0 & 0 & \frac{1}{\sqrt{3}}Im(\lambda) & \frac{-1}{\sqrt{3}}Im(\lambda\omega) & \frac{-1}{\sqrt{3}}Im(\lambda\bar{\omega}) \\ -1 & 1 & 0 & 0 & \frac{1}{\sqrt{3}}Im(\lambda) & \frac{-1}{\sqrt{3}}Im(\lambda\omega) & \frac{-1}{\sqrt{3}}Im(\lambda\bar{\omega}) \\ \frac{1}{\sqrt{3}}Im(\lambda\bar{\omega}) & \frac{1}{\sqrt{3}}Im(\lambda\bar{\omega}) & \frac{1}{\sqrt{3}}Im(\lambda) & \frac{1}{\sqrt{3}}Im(\lambda) & 0 & 2Re(\lambda) & -2Re(\lambda\bar{\omega}) \\ \frac{-1}{\sqrt{3}}Im(\lambda) & \frac{-1}{\sqrt{3}}Im(\lambda) & \frac{-1}{\sqrt{3}}Im(\lambda\omega) & \frac{-1}{\sqrt{3}}Im(\lambda\omega) & 2Re(\lambda) & 0 & -2Re(\lambda\omega) \\ \frac{1}{\sqrt{3}}Im(\lambda\omega) & \frac{1}{\sqrt{3}}Im(\lambda\omega) & \frac{-1}{\sqrt{3}}Im(\lambda\bar{\omega}) & \frac{-1}{\sqrt{3}}Im(\lambda\bar{\omega}) & -2Re(\lambda\bar{\omega}) & -2Re(\lambda\omega) & 0 \end{bmatrix}$$

with eigenvalue $\frac{1}{7^2}$ where $\xi \in P_{2,+}^{Spin}$ by the identification $\xi = \sum_{i,j=1}^7 \xi_{i,j} \hat{i} \otimes \hat{j}$. Thus every subfactor from this continuous family is infinite depth.

This eigenvector was found numerically in Matlab and verified using the Symbolic Math Toolbox. The Matlab code used can be found in the appendix.

Example 4.2.4. Let p be a prime and $m \in \mathbb{N}$ such that $p^m \equiv 1 \pmod{4}$. Then the Galois field of order $q = p^m$, \mathbb{F}_q , has a quadratic character

$$\chi(a) = \begin{cases} 0 & \text{if } a = 0 \\ 1 & \text{if } a = b^2 \text{ for some } b \in \mathbb{F}_q \setminus \{0\} \\ -1 & \text{if } a \neq b^2 \text{ for any } b \in \mathbb{F}_q \setminus \{0\} \end{cases} .$$

Let $j_{n,m}$ be the $n \times m$ matrix of ones, I_n the $n \times n$ identity matrix, and define the $q \times q$ matrix, $K_{a,b} = \chi(a-b)$,

indexed by \mathbb{F}_q . Then the $2(q+1) \times 2(q+1)$ Paley type II Hadamard matrix ([Pal33]) is given by

$$H = \begin{bmatrix} 0 & j_{1,q} \\ j_{q,1} & K \end{bmatrix} \otimes \begin{bmatrix} 1 & 1 \\ 1 & -1 \end{bmatrix} + I_{q+1} \otimes \begin{bmatrix} 1 & -1 \\ -1 & -1 \end{bmatrix}.$$

Letting u be the corresponding biunitary from H and $Q = 2(q+1)$, $Q\theta_u|_{P_{2,+}^{Spin}}$ has an eigenvector

$$\xi = \begin{bmatrix} 0 & 0 \\ 0 & K \end{bmatrix} \otimes \begin{bmatrix} 1 & 0 \\ 0 & -1 \end{bmatrix}$$

with eigenvalue $\lambda = \frac{4^2q}{(q+1)^2}$. Since q is a prime power congruent to 1 mod 4, λ is not an algebraic integer and so Paley type II Hadamard matrices yield infinite depth subfactors.

Proof. Since the type II Paley Hadamard matrices are more easily expressed using tensors, we will work in a tensor product of planar algebras as defined in [Jon21]. Letting $P^{Spin,Q}$ denote the spin planar algebra with Q spins, it can be shown that $P^{Spin,q+1} \otimes P^{Spin,2} \cong P^{Spin,2(q+1)}$ by a bijection,

$$\{\hat{i} \otimes \hat{j} \mid i = 1, \dots, q+1, j = 1, 2\} \leftrightarrow \{\hat{k} \mid k = 1, \dots, 2(q+1)\}.$$

We will also identify matrices with the 2-box spaces of P^{Spin} via $(a_{i,j})_{i,j=1}^Q = \sum_{i,j} a_{i,j} \hat{i} \otimes \hat{j}$. Non-self adjoint matrices will be marked with a plus, $[\cdot]_+$, or a minus, $[\cdot]_-$, to denote whether they belong to $P_{2,+}^{Spin}$ or $P_{2,-}^{Spin}$.

Define the following 2×2 and $q+1 \times q+1$ matrices.

$$\begin{aligned} H_+ &= \begin{bmatrix} 1 & 1 \\ 1 & -1 \end{bmatrix} & H_- &= \begin{bmatrix} 1 & -1 \\ -1 & -1 \end{bmatrix} & D &= \begin{bmatrix} 1 & 0 \\ 0 & -1 \end{bmatrix} & E &= \begin{bmatrix} 0 & 1 \\ -1 & 0 \end{bmatrix}_- \\ S &= \begin{bmatrix} 0 & 0 \\ 0 & K \end{bmatrix} & T &= \begin{bmatrix} 0 & 0 \\ 0 & j_{q,q} - I_q \end{bmatrix} & J &= \begin{bmatrix} 0 & j_{1,q} \\ j_{q,1} & 0 \end{bmatrix} \\ L &= \begin{bmatrix} 0 & 0 \\ j_{q,1} & 0 \end{bmatrix}_- & M &= \begin{bmatrix} 0 & -j_{1,q} \\ j_{q,1} & 0 \end{bmatrix}_- \end{aligned}$$

Then $H = I_{q+1} \otimes H_- + J \otimes H_+ + S \otimes H_+$ and $\xi = S \otimes D$. Since $q \cong 1 \pmod{4}$, K is symmetric, and so

$H = H^* = H^t = \overline{H}$ and $\xi = \xi^* = \xi^t = \overline{\xi}$. This implies that orienting strings and marked intervals for ξ are unnecessary. Similarly, marked intervals will also be omitted for real, self-adjoint matrices in the following computations. To evaluate $Q\theta_u(\xi)$, we first compute

$$\phi_u(\xi) = \begin{array}{c} \text{\$} \\ \text{\$} \end{array} \left[\begin{array}{c} \text{\$} \\ \text{\$} \end{array} \right] \xi \left[\begin{array}{c} \text{\$} \\ \text{\$} \end{array} \right] \text{\$}.$$

For each intersection of strings we must substitute in H . Since H is a sum of three simple tensors, $\phi_u(\xi)$ decomposes into a sum of 3^4 tangles with disks filled by the terms $S \otimes D$, $I_{q+1} \otimes H_-$, $J \otimes H_+$, or $S \otimes H_+$. The following identities force all but eight of these terms to be zero. Marked intervals will be omitted when the identity holds for any choice of marked intervals.

$$(i) \quad I_{q+1} = \frac{1}{\sqrt{q+1}} \left[\begin{array}{c} \text{\$} \\ \text{\$} \end{array} \right] \in P_{2,+}^{Spin,q+1}.$$

$$(ii) \quad \left[\begin{array}{c} \text{\$} \\ \text{\$} \end{array} \right] S = \left[\begin{array}{c} \text{\$} \\ \text{\$} \end{array} \right] J = \left[\begin{array}{c} \text{\$} \\ \text{\$} \end{array} \right] M = \left[\begin{array}{c} \text{\$} \\ \text{\$} \end{array} \right] T = 0.$$

$$(iii) \quad \left[\begin{array}{c} \text{\$} \\ \text{\$} \end{array} \right] S J S = \left[\begin{array}{c} \text{\$} \\ \text{\$} \end{array} \right] S M S = 0. \text{ Similarly, any of the } S \text{ disks may be replaced by } T \text{ yielding zero as well.}$$

$$(iv) \quad \left[\begin{array}{c} \text{\$} \\ \text{\$} \end{array} \right] \begin{array}{c} H_+ \quad H_+ \\ D \\ H_+ \quad H_+ \end{array} = \left[\begin{array}{c} \text{\$} \\ \text{\$} \end{array} \right] \begin{array}{c} H_- \quad H_- \\ D \\ H_+ \quad H_+ \end{array} = \left[\begin{array}{c} \text{\$} \\ \text{\$} \end{array} \right] \begin{array}{c} H_- \quad H_+ \\ D \\ H_+ \quad H_- \end{array} = 0.$$

$$(v) \quad \left[\begin{array}{c} \text{\$} \\ \text{\$} \end{array} \right] \begin{array}{c} H_+ \quad H_+ \\ E \\ H_+ \quad H_+ \end{array} = \left[\begin{array}{c} \text{\$} \\ \text{\$} \end{array} \right] \begin{array}{c} H_- \quad H_- \\ E \\ H_+ \quad H_+ \end{array} = \left[\begin{array}{c} \text{\$} \\ \text{\$} \end{array} \right] \begin{array}{c} H_- \quad H_+ \\ E \\ H_+ \quad H_- \end{array} = 0.$$

$$(vi) \quad \left[\begin{array}{c} \text{\$} \\ \text{\$} \end{array} \right] \begin{array}{c} H_- \quad H_+ \\ D \\ H_+ \quad H_+ \end{array} = \begin{bmatrix} 1 & -1 \\ 1 & -1 \end{bmatrix}_- \quad \left[\begin{array}{c} \text{\$} \\ \text{\$} \end{array} \right] \begin{array}{c} H_- \quad H_+ \\ E \\ H_+ \quad H_+ \end{array} = \begin{bmatrix} -1 & -1 \\ 1 & 1 \end{bmatrix}_+.$$

Due to (iv), terms of $\phi_u(\xi)$ without $I_{q+1} \otimes H_-$ are zero. By (i), terms with two or more $I_{q+1} \otimes H_-$'s are zero due to (ii), (iii), or (iv) depending on the placement of $I_{q+1} \otimes H_-$ terms. Thus all nonzero terms contain

one instance of $I_{q+1} \otimes H_-$. Due to (iii), terms with exactly one $I_{q+1} \otimes H_-$ and one $J \otimes H_+$ disks are zero. (iii) further restricts how $J \otimes H_+$ and $S \otimes H_+$ can be arranged to yield nonzero terms. Therefore the only nonzero terms are

$$\frac{1}{\sqrt{q+1}} \left(\begin{array}{|c|c|c|} \hline \text{\$} & & \text{\$} \\ \hline & S & \\ \hline & S & \\ \hline & S & \\ \hline \end{array} \right) \otimes \left(\begin{array}{|c|c|c|} \hline \text{\$} & & \text{\$} \\ \hline & H_- & H_+ \\ \hline & D & \\ \hline & H_+ & H_+ \\ \hline \end{array} \right), \quad \frac{1}{\sqrt{q+1}} \left(\begin{array}{|c|c|c|} \hline \text{\$} & & \text{\$} \\ \hline & J & \\ \hline & S & \\ \hline & S & \\ \hline \end{array} \right) \otimes \left(\begin{array}{|c|c|c|} \hline \text{\$} & & \text{\$} \\ \hline & H_- & H_+ \\ \hline & D & \\ \hline & H_+ & H_+ \\ \hline \end{array} \right),$$

their adjoints, and rotations by ρ^2 (i.e. π radians). Since $Kj_{q,q} = 0$, we have

$$\left(\begin{array}{|c|c|} \hline \text{\$} & \text{\$} \\ \hline S & S \\ \hline \end{array} \right) = \left(\begin{array}{|c|c|} \hline \text{\$} & \text{\$} \\ \hline T & \\ \hline \end{array} \right) \quad \text{and} \quad \left(\begin{array}{|c|c|} \hline \text{\$} & \text{\$} \\ \hline T & S \\ \hline \end{array} \right) = -\frac{1}{\sqrt{q+1}} \left(\begin{array}{|c|c|} \hline \text{\$} & \text{\$} \\ \hline S & \\ \hline \end{array} \right).$$

Applying these to the left-hand term in $\phi_u(\xi)$ yields $-\frac{1}{q+1} \left(\begin{array}{|c|c|} \hline \text{\$} & \text{\$} \\ \hline T & \\ \hline \end{array} \right) \otimes \begin{bmatrix} 1 & -1 \\ 1 & -1 \end{bmatrix}_-$. This term, its adjoint,

and rotations by ρ^2 sum to $-\frac{4}{q+1} T \otimes D$. Similarly, since

$$\left(\begin{array}{|c|c|} \hline \text{\$} & \text{\$} \\ \hline T & J \\ \hline \end{array} \right) = \frac{q-1}{\sqrt{q+1}} \left(\begin{array}{|c|c|} \hline \text{\$} & \text{\$} \\ \hline L & \text{\$} \\ \hline \end{array} \right) \quad \text{and} \quad \left(\begin{array}{|c|c|} \hline \text{\$} & \text{\$} \\ \hline J & L \\ \hline \end{array} \right) = \left(\begin{array}{|c|c|} \hline \text{\$} & \text{\$} \\ \hline L & \\ \hline \end{array} \right),$$

the right-hand term of $\phi_u(S \otimes D)$ evaluates to $\frac{q-1}{q+1} \left(\begin{array}{|c|c|} \hline \text{\$} & \text{\$} \\ \hline L & \text{\$} \\ \hline \end{array} \right) \otimes \begin{bmatrix} 1 & -1 \\ 1 & -1 \end{bmatrix}_-$. This term, its adjoint, and rotations sum to

$$\frac{2(q-1)}{q+1} \left(\left(\begin{array}{|c|c|} \hline \text{\$} & \text{\$} \\ \hline L & \text{\$} \\ \hline \end{array} \right) \otimes \begin{bmatrix} 1 & 1 \\ -1 & -1 \end{bmatrix}_- + \left(\begin{array}{|c|c|} \hline \text{\$} & \text{\$} \\ \hline L & \text{\$} \\ \hline \end{array} \right) \otimes \begin{bmatrix} 1 & -1 \\ 1 & -1 \end{bmatrix}_- \right) = \frac{2(q-1)}{q+1} (J \otimes D + M \otimes E),$$

and so

$$\phi_u(\xi) = -\frac{4}{q+1} T \otimes D + \frac{2(q-1)}{q+1} (J \otimes D + M \otimes E).$$

Letting

$$\phi_u^*(\eta) = \left(\begin{array}{|c|} \hline \text{\$} \\ \hline \text{\$} \eta \\ \hline \text{\$} \\ \hline \end{array} \right),$$

we must evaluate $\phi_u^*(T \otimes D)$, $\phi_u^*(J \otimes D)$, and $\phi_u^*(M \otimes E)$. Fortunately, T , J , M , and E satisfy similar identities to S and D which forces most terms of $\phi_u^*(\phi_u(\xi))$ to be zero. The same argument given above implies that nonzero terms from $\phi_u^*(T \otimes D)$, $\phi_u^*(J \otimes D)$, or $\phi_u^*(M \otimes E)$ contain exactly one instance of $I_{q+1} \otimes H_-$.

We now evaluate $\phi_u^*(T \otimes D)$. Identity (iii) restricts how $J \otimes H_+$ and $S \otimes H_+$ can be arranged to yield nonzero terms. Thus the only nonzero terms of $\phi_u^*(T \otimes D)$ are

$$\frac{1}{\sqrt{q+1}} \left[\begin{array}{c} \text{\$} \\ \text{S} \text{---} \text{T} \text{---} \text{S} \\ \text{S} \end{array} \right] \otimes \left[\begin{array}{c} \text{\$} \\ \text{H}_- \text{---} \text{H}_+ \\ \text{D} \\ \text{H}_+ \text{---} \text{H}_+ \end{array} \right], \quad \frac{1}{\sqrt{q+1}} \left[\begin{array}{c} \text{\$} \\ \text{S} \text{---} \text{T} \text{---} \text{S} \\ \text{J} \end{array} \right] \otimes \left[\begin{array}{c} \text{\$} \\ \text{H}_- \text{---} \text{H}_+ \\ \text{D} \\ \text{H}_+ \text{---} \text{H}_+ \end{array} \right],$$

their adjoints, and rotations by ρ^2 . The left-hand term can be evaluated with a nontrivial fact of K . It can be shown that $K^2 = qI_q - j_{q,q}$ using basic properties of \mathbb{F}_q and χ . Then

$$\begin{aligned} & \frac{1}{\sqrt{q+1}} \left[\begin{array}{c} \text{\$} \\ \text{S} \text{---} \text{T} \text{---} \text{S} \\ \text{S} \end{array} \right] \otimes \left[\begin{array}{c} \text{\$} \\ \text{H}_- \text{---} \text{H}_+ \\ \text{D} \\ \text{H}_+ \text{---} \text{H}_+ \end{array} \right] = \frac{1}{\sqrt{q+1}} \left[\begin{array}{c} \text{\$} \\ \text{S} \text{---} \text{T} \text{---} \text{S} \\ \text{S} \end{array} \right] \otimes \begin{bmatrix} 1 & -1 \\ 1 & -1 \end{bmatrix}_+ \\ & = \frac{q}{(q+1)^{3/2}} \left[\begin{array}{c} \text{\$} \\ \text{S} \text{---} \text{T} \text{---} \text{S} \\ \text{S} \end{array} \right] \otimes \begin{bmatrix} 1 & -1 \\ 1 & -1 \end{bmatrix}_+ - \frac{1}{q+1} S \otimes \begin{bmatrix} 1 & -1 \\ 1 & -1 \end{bmatrix}_+ = -\frac{1}{q+1} S \otimes \begin{bmatrix} 1 & -1 \\ 1 & -1 \end{bmatrix}_+. \end{aligned}$$

The right-hand term from $\phi_u^*(T \otimes D)$ is zero since

$$\left[\begin{array}{c} \text{\$} \\ \text{S} \text{---} \text{T} \end{array} \right] = \left[\begin{array}{c} \text{\$} \\ \text{S} \end{array} \right] \quad \text{and} \quad \left[\begin{array}{c} \text{\$} \\ \text{S} \text{---} \text{J} \end{array} \right] = 0.$$

Therefore

$$\phi_u^*(T \otimes D) = -\frac{4}{q+1} S \otimes D.$$

We now evaluate $\phi_u^*(J \otimes D)$. By identity (iii), nonzero terms of $\phi_u^*(J \otimes D)$ cannot contain more than

one instance of $S \otimes H_+$. This yields twelve terms of $\phi_u^*(J \otimes D)$,

$$\begin{aligned} & \frac{1}{\sqrt{q+1}} \left[\begin{array}{|c|} \hline \$ \\ \hline \end{array} \begin{array}{c} J \\ J \\ J \end{array} \otimes \begin{array}{|c|} \hline \$ \\ \hline \end{array} \begin{array}{c} H_- \\ D \\ H_+ \end{array} \right], \quad \frac{1}{\sqrt{q+1}} \left[\begin{array}{|c|} \hline \$ \\ \hline \end{array} \begin{array}{c} J \\ J \\ S \end{array} \otimes \begin{array}{|c|} \hline \$ \\ \hline \end{array} \begin{array}{c} H_- \\ D \\ H_+ \end{array} \right], \\ & \frac{1}{\sqrt{q+1}} \left[\begin{array}{|c|} \hline \$ \\ \hline \end{array} \begin{array}{c} J \\ J \\ S \end{array} \otimes \begin{array}{|c|} \hline \$ \\ \hline \end{array} \begin{array}{c} H_- \\ D \\ H_+ \end{array} \right], \end{aligned}$$

their adjoints, and rotations by ρ^2 . Since

$$\begin{aligned} \begin{array}{|c|} \hline \$ \\ \hline \end{array} \begin{array}{c} J \\ J \end{array} &= \begin{array}{|c|} \hline \$ \\ \hline \end{array} \begin{array}{c} J \end{array}, \quad \begin{array}{|c|} \hline \$ \\ \hline \end{array} \begin{array}{c} J \\ J \end{array} = \frac{1}{\sqrt{q+1}} \begin{bmatrix} q & 0 \\ 0 & j_{q,q} \end{bmatrix}_+ = \frac{1}{\sqrt{q+1}} J^2, \\ \begin{array}{|c|} \hline \$ \\ \hline \end{array} \begin{array}{c} J \\ S \end{array} &= 0, \quad \text{and} \quad \begin{array}{|c|} \hline \$ \\ \hline \end{array} \begin{array}{c} J \\ J^2 \end{array} = 0, \end{aligned}$$

where J^2 denotes the matrix product of $J \cdot J$, the first two terms are zero and the last term of $\phi_u^*(J \otimes D)$ becomes

$$\frac{1}{\sqrt{q+1}} \left[\begin{array}{|c|} \hline \$ \\ \hline \end{array} \begin{array}{c} J \\ J \\ S \end{array} \otimes \begin{array}{|c|} \hline \$ \\ \hline \end{array} \begin{array}{c} H_- \\ D \\ H_+ \end{array} \right] = \frac{1}{q+1} \left[\begin{array}{|c|} \hline \$ \\ \hline \end{array} \begin{array}{c} S \\ J^2 \end{array} \otimes \begin{bmatrix} 1 & -1 \\ 1 & -1 \end{bmatrix}_+ \right] = \frac{1}{q+1} S \otimes \begin{bmatrix} 1 & -1 \\ 1 & -1 \end{bmatrix}_+.$$

Therefore

$$\phi_u^*(J \otimes D) = \frac{4}{q+1} S \otimes D.$$

Finally, we must evaluate $\phi_u^*(M \otimes E)$. Due to identity (v), the analysis of $\phi_u^*(J \otimes D)$ applies to $\phi_u^*(M \otimes E)$.

This yields twelve terms of $\phi_u^*(M \otimes E)$,

$$\frac{1}{\sqrt{q+1}} \left[\begin{array}{|c|} \hline \$ \\ \hline \end{array} \begin{array}{c} J \\ M \\ J \end{array} \otimes \begin{array}{|c|} \hline \$ \\ \hline \end{array} \begin{array}{c} H_- \\ E \\ H_+ \end{array} \right], \quad \frac{1}{\sqrt{q+1}} \left[\begin{array}{|c|} \hline \$ \\ \hline \end{array} \begin{array}{c} J \\ M \\ S \end{array} \otimes \begin{array}{|c|} \hline \$ \\ \hline \end{array} \begin{array}{c} H_- \\ E \\ H_+ \end{array} \right],$$

$$\frac{1}{\sqrt{q+1}} \left[\begin{array}{|c|c|c|} \hline \$ & & \\ \hline S & M & J \\ \hline S & M & J \\ \hline \end{array} \right] \otimes \left[\begin{array}{|c|c|c|} \hline \$ & & \\ \hline H_- & E & H_+ \\ \hline H_+ & E & H_+ \\ \hline \end{array} \right],$$

their adjoints, and rotations by ρ^2 . Since

$$\begin{aligned} \left[\begin{array}{|c|c|} \hline \$ & \\ \hline M & J \\ \hline \end{array} \right] &= \left[\begin{array}{|c|c|} \hline \$ & \$ \\ \hline M & \\ \hline \end{array} \right], & \left[\begin{array}{|c|c|} \hline \$ & \\ \hline J & M \\ \hline \end{array} \right] &= \frac{1}{\sqrt{q+1}} \begin{bmatrix} q & 0 \\ 0 & -j_{q,q} \end{bmatrix}_+ = \frac{1}{\sqrt{q+1}} JM, \\ \left[\begin{array}{|c|c|} \hline \$ & \\ \hline S & M \\ \hline \end{array} \right] &= 0, & \text{and} & \left[\begin{array}{|c|c|} \hline \$ & \\ \hline J & JM \\ \hline \end{array} \right] &= 0, \end{aligned}$$

the first two terms are zero and the last term of $\phi_u^*(M \otimes E)$ becomes

$$\frac{1}{\sqrt{q+1}} \left[\begin{array}{|c|c|c|} \hline \$ & & \\ \hline S & M & J \\ \hline S & M & J \\ \hline \end{array} \right] \otimes \left[\begin{array}{|c|c|c|} \hline \$ & & \\ \hline H_- & E & H_+ \\ \hline H_+ & E & H_+ \\ \hline \end{array} \right] = \frac{1}{q+1} \left[\begin{array}{|c|c|} \hline \$ & \\ \hline S & JM \\ \hline \end{array} \right] \otimes \begin{bmatrix} -1 & -1 \\ 1 & 1 \end{bmatrix}_+ = \frac{1}{q+1} S \otimes \begin{bmatrix} 1 & 1 \\ -1 & -1 \end{bmatrix}_+.$$

Therefore

$$\phi_u^*(M \otimes E) = \frac{4}{q+1} S \otimes D.$$

Combining these computations yields $Q\theta_u(\xi) = \frac{4^2 q}{(q+1)^2} \xi$. □

Since $q \equiv 1 \pmod{4}$ is a prime power, $2(q+1)$ is of the form $4n$ for some $n \geq 3$ and odd. By proposition 3.2.9 subfactors from Paley type *II* Hadamard matrices are at least two super-transitive (i.e. the principal graph up to depth two is the same as A_∞ up to depth two).

CHAPTER 5

Generalizations to Commuting Squares

So far we have been focusing on the spin model subfactors and the spin model commuting squares. In this chapter we define an angle operator for general symmetric commuting squares and perform the same analysis of the angle operator. First we must define an appropriate planar algebra.

5.1 The Colored Graph Planar Algebra

Let Γ be a finite weighted k -partite graph. We will define a k -colored planar algebra $P^{\Gamma,c}$ associated to Γ called the colored graph planar algebra. The following construction is essentially Jones's graph planar algebra defined in [Jon19] with an added coloring. A very similar planar algebra can also be found in [MP14].

Definition 5.1.1. A *k -colored planar tangle* T is a planar tangle T where the regions of T are assigned colors $\{1, \dots, k\}$ such that every string in T belongs to the boundary of two regions with different colors. The disks of T are categorized with the boundary data ∂_n which is the collection of sequences of n colors $c_1 \dots c_n$, $c_i \in \{1, \dots, k\}$ such that $c_i \neq c_{i+1}$ and $c_1 \neq c_n$. Starting with the marked interval of a disk D and reading the coloring of adjacent regions counter-clockwise gives the boundary data of the disk ∂D . We classify tangles by the boundary data of their output disk ∂D^T .

Example 5.1.2. Figure 5.1 is an example of a *bgbyryrbg*-tangle.

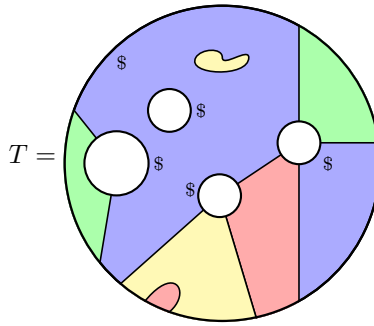

Figure 5.1: Colored Planar Tangle

Definition 5.1.3. Let Γ be a finite weighted k -partite graph, $k \geq 2$, with parts $\{\Gamma_i\}_{i=1}^k$ and nonzero weights $\mu: V(\Gamma) \rightarrow \mathbb{C}$. The elements of $\{1, \dots, k\}$ will denote the colors for the colored planar algebra. For $n \in \mathbb{N}$

let ∂_n be the collection of sequences of n colors $c_1 \dots c_n$, $c_i \in \{1, \dots, k\}$ such that $c_i \neq c_{i+1}$ and $c_1 \neq c_n$.

Define $\mathcal{L}_\partial = V(\Gamma_\partial)$ for $\partial \in \partial_1$,

$$\mathcal{L}_\partial = \{ \text{pointed oriented loops } (v_1, e_1, v_2, e_2, \dots, v_n, e_n) \mid e_i \in E(\Gamma_{c_i}, \Gamma_{c_{i+1}}) \text{ and } \partial = c_1, \dots, c_n \}$$

for $\partial \in \partial_n$ and $P_\partial^{\Gamma, c} = \mathbb{C}[[\mathcal{L}_\partial]]$, the vector space of all functions on \mathcal{L}_∂ . We will need the following objects to turn this into a planar algebra:

(1) A state σ on a k -colored planar tangle T is a map

$$\sigma: \{ \text{regions of } T \} \amalg \{ \text{strings of } T \} \rightarrow \{ \text{vertices of } \Gamma \} \amalg \{ \text{edges of } \Gamma \}$$

such that σ sends i colored regions to vertices in the Γ_i component and strings to edges such that if R_1 and R_2 are two regions both having S as part of their boundary, then $\sigma(S)$ is an edge of Γ connecting $\sigma(R_1)$ and $\sigma(R_2)$. For each disk D we define a pointed oriented loop $\sigma(D) = (\sigma(r_1), \sigma(s_1), \dots, \sigma(r_n), \sigma(s_n))$ where the r_i 's and s_i 's are the regions and strings adjacent to D when read off the boundary of D in a counter-clockwise direction starting at the marked interval.

(2) Given a k -colored planar tangle T and a region r in T , define $\text{Rot}(r)$ as follows: Remove input disks with zero boundary points. Then give r a counter-clockwise orientation which induces an orientation on the boundary of r which is piecewise smooth. Define $\text{Rot}(r)$ as the rotation number of the oriented boundary of r .

(3) Given a state σ on a k -colored planar tangle T , define

$$\text{Rot}(\sigma) = \prod_{\substack{\text{regions} \\ r \text{ of } T}} \mu(\sigma(r))^{\text{Rot}(r)}.$$

(4) Let T be a ∂ -tangle for $\partial \in \partial_n$ and fix a loop $\eta = (v_1, e_1, \dots, v_n, e_n) \in \mathcal{L}_{\partial(D^T)}$. Define $\mu(\eta) = \prod_{i=1}^n \mu(v_i)^{-1}$.

Define the action of a tangle T with a labelling $f \in \prod_{D \in \mathcal{D}_T} P_{\partial D}^{\Gamma, c}$ by

$$Z_T(f)(\eta) = \sum_{\substack{\text{states } \sigma \text{ of } T \\ \text{with } \eta \in \mathcal{L}_{\partial D^T}}} \mu(\eta) \text{Rot}(\sigma) \prod_{D \in \mathcal{D}_T} f(D)(\sigma(D)).$$

$P^{\Gamma,c}$ also has a $*$ -structure. Let η^{-1} denote the path η traversed in the reverse order and $\partial^{-1} = c_1 c_n c_{n-1} \dots c_2$ where $\partial = c_1 c_2 \dots c_n$. Define $*$: $P_{\partial}^{\Gamma,c} \rightarrow P_{\partial^{-1}}^{\Gamma,c}$ by $f^*(\eta) = \overline{f(\eta^{-1})}$.

Theorem 5.1.4. P^C is a non-degenerate unital colored planar $*$ -algebra.

Proof. The colored graph planar algebra can be derived from the graph planar algebra in [Jon21] or [Jon19]. Define the projections to each Γ_i , $p_i \in P_0^{\Gamma}$ $p_i(v) = 1_{\delta_{v \in \Gamma_i}}$. Given a k -colored tangle, T , we define a partially filled vanilla tangle, \tilde{T} , for P^{Γ} . For each i -colored region insert an input disk with the projection p_i and remove the coloring. The action of T on the colored planar algebra is precisely the action of \tilde{T} when $P_{\partial}^{\Gamma,c}$ is viewed as a subspace of P_n^{Γ} where ∂ has length n . Proving that $P^{\Gamma,c}$ is a unital planar $*$ -algebra now follows from P^{Γ} being a unital planar $*$ -algebra. The map $T \rightarrow \tilde{T}$ turns P^{Γ} into a k -colored planar algebra, but it will be degenerate in general. We can restrict to subspaces of P_n^{Γ} to obtain a non-degenerate planar algebra. This restriction yields $P_{\partial}^{\Gamma,c}$. \square

Remark 5.1.5. If the weights $\mu(v) > 0$ for all v and $\partial = c_1 c_2 \dots c_n c_{n-1} \dots c_2$ then $P_{\partial}^{\Gamma,c}$ has a C^* -algebra structure. This can be shown by viewing $P_{\partial}^{\Gamma,c}$ as a subspace of $P_{2(n-1)}^{\Gamma}$ and observing that the colored multiplication tangle induces the same product as the vanilla multiplication tangle.

$$B \subset C$$

Example 5.1.6. Let $\begin{array}{ccc} & B & C \\ \cup & & \cup \\ A & & D \end{array}$ be a symmetric commuting square with connected inclusions. We have a

$$A \subset D$$

unique inclusion $\mathbb{C} \subset A$ and its corresponding Bratteli diagram. Define a 5-partite weighted graph Γ in the following way:

- (i) $V(\Gamma) =$ Equivalence classes of minimal projections in the algebras \mathbb{C} , A , B , C , or D .
- (ii) Define the edges of Γ from the Bratteli diagrams for $\mathbb{C} \subset A$, $A \subset B$, $B \subset C$, $A \subset D$, and $D \subset C$.
- (iii) The five parts of Γ are induced by the five algebras \mathbb{C} , A , B , C , or D . Let the colors white, yellow, green, blue, and red denote \mathbb{C} , A , B , C , or D respectively.
- (iv) For $F \in \{A, B, C, D\}$ let $\Gamma^{A \subset F}: \mathbb{C}[V(F)] \rightarrow \mathbb{C}[V(A)]$ be the adjacency matrix for the Bratteli diagram for $A \subset F$. Let p be a minimal projection in $F \in \{A, B, C, D\}$ and define $t_{[p]}^F = tr_C(p)$ where tr_C is the unique normalized Markov trace for $B \subset C$. Define $\mu([p]) = \|\Gamma^{A \subset F}\| t_{[p]}^F$. For \mathbb{C} which has one minimal projection, 1 , we define $\mu([1]) = 1$.

We will refer to P^C as the planar algebra of the symmetric commuting square $\mathcal{C} = \begin{pmatrix} B & \subset & C \\ \cup & & \cup \\ A & \subset & D \end{pmatrix}$.

Lemma 5.1.7. *The loop parameters of P^C are given by the norms of Bratteli diagrams, $\delta_h = \|\Gamma^{ACB}\| = \|\Gamma^{DCC}\|$ and $\delta_v = \|\Gamma^{ACD}\| = \|\Gamma^{BCC}\|$.*

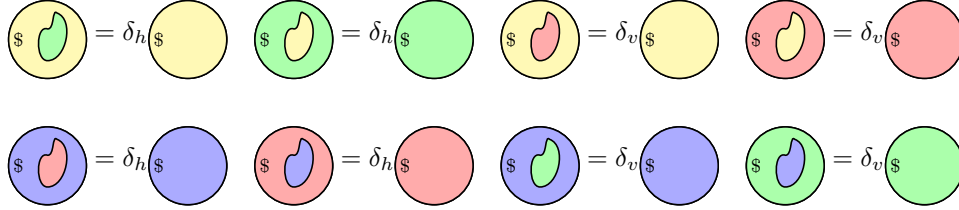

Loops bounding a white shaded region do not generate loop parameters but choosing $\nu, \nu^{-1} \in P_{wy}^C$,

$\nu(v_C, e_1, v_A, e_2) = \delta_{e_1=e_2} \sqrt{\frac{\mu(v_A)}{\#E(v_C, v_A)}}$, and $\nu^{-1}(v_C, e_1, v_A, e_2) = \delta_{e_1=e_2} \sqrt{\frac{\#E(v_C, v_A)}{\mu(v_A)}}$, we have the following equalities:

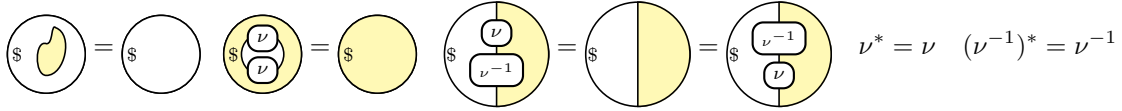

Proof. These are straight-forward computations with the following observations. Since we started with a symmetric commuting square, the trace vectors $t^F = (t_v^F)_{v \in F}$, $F \in \{A, B, C, D\}$ are Perron Frobenius vectors for every inclusion matrix acting on them, [JS97]. In fact $\Gamma^{ACF} t^F = t^A$ and $(\Gamma^{ACF})^* t^A = \|\Gamma^{ACF}\|^2 t^F$. Therefore

$$\Gamma^{ACC} (\Gamma^{ACC})^* t^A = \Gamma^{ACB} \Gamma^{BCC} (\Gamma^{BCC})^* (\Gamma^{ACB})^* t^A = \|\Gamma^{ACB}\|^2 \|\Gamma^{BCC}\|^2 t^A$$

and so $\|\Gamma^{BCC}\| \|\Gamma^{DCC}\| = \|\Gamma^{ACC}\|$. □

Definition 5.1.8. *Let $\xi, \eta \in P_{\partial}^C$ where ∂ begins with w . Define an inner product on P_{∂}^C , called the **planar algebra inner product** by the tangle*

$$\langle \xi | \eta \rangle_{\mathcal{C}} = \left[\begin{array}{c} \text{\$} \\ \text{\$} \eta^* \quad \vdots \quad \xi \text{\$} \\ \text{\$} \end{array} \right]_{\mathcal{C}}$$

and the associated norm will be denoted, $\|\cdot\|_C$. This inner product is positive definite since it is equal to the inner product in the graph planar algebra P^Γ . We have only restricted to the subspace P_∂^C . Furthermore, this inner product is an unnormalized tracial inner product when P_∂^C forms a C^* -algebra.

$$B \subset C$$

Proposition 5.1.9. Let $(U_{\alpha,\beta})_{\alpha,\beta}$ be the biunitary for a symmetric commuting square $\begin{array}{ccc} & B & C \\ U & \cup & \cup \\ & A & D \end{array}$. Define

$$A \subset D$$

the element $U \in P_{ygbv}^C$ by

$$U(\gamma) = \frac{1}{\sqrt{\mu(v_B)\mu(v_D)}} U_{\alpha,\beta}$$

where $\gamma = (v_A, e_{A,B}, v_B, e_{B,C}, v_C, e_{C,D}, v_D, e_{D,A})$, $\alpha = (v_A, e_{A,B}, v_B, e_{B,C}, v_C)$, and $\beta = (v_A, e_{D,A}, v_D, e_{C,D}, v_C)$. Then U is a biunitary in the planar algebra P^C (i.e. U and it's rotation $\rho(U)$ are unitaries).

Proof. We must show the following equalities for U .

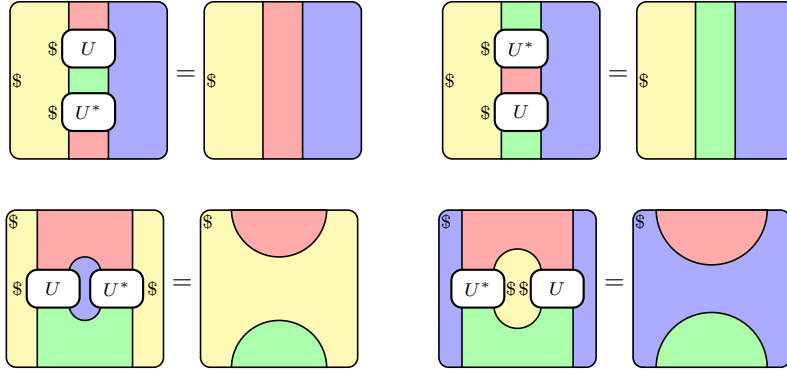

Here we show the computations verifying two of these equalities and the other two computations are identical. A key component to both of these computations is proposition 2.2.6. Since $(U_{\alpha,\beta})_{\alpha,\beta}$ is a unitary we have

$$Z_T(f)(\eta) = \sum_{\beta_1, \beta_2} \begin{array}{c} \eta_4 \quad v_4 \quad \eta_3 \\ v_1 \quad \$ \quad U \\ \beta_1 \quad v_5 \quad \beta_2 \\ \$ \quad U^* \quad v_3 \\ \eta_1 \quad v_2 \quad \eta_2 \end{array} = \sum_{\beta_1, \beta_2} \mu(v_5) U(\beta_1 \beta_2 \eta_3 \eta_4) \overline{U(\beta_1 \beta_2 \eta_2 \eta_1)}$$

$$\sum_{\beta_1, \beta_2} \frac{\mu(v_5)}{\sqrt{\mu(v_2)\mu(v_4)\mu(v_5)^2}} U_{\beta_1 \circ \beta_2, \eta_4 \circ \eta_3} \overline{U_{\beta_1 \circ \beta_2, \eta_1 \circ \eta_2}} = \frac{\delta_{\eta_2=\eta_3} \delta_{\eta_1=\eta_4}}{\sqrt{\mu(v_2)\mu(v_4)}} = \begin{array}{c} \eta_4 \quad v_4 \quad \eta_3 \\ v_1 \quad \$ \\ \eta_1 \quad v_2 \quad \eta_2 \end{array}.$$

Letting v_1, v_2, v_3 , and v_4 be vertices in A, B, C , and D respectively, observe that $\frac{\mu(v_1)\mu(v_3)}{\mu(v_2)\mu(v_4)} = \frac{t_{v_1}^A t_{v_3}^C}{t_{v_2}^B t_{v_4}^D}$ since $\|\Gamma^{B \subset C}\| \|\Gamma^{D \subset C}\| = \|\Gamma^{A \subset C}\|$. Then since $(U_{\alpha, \beta})_{\alpha, \beta}$ is a biunitary we have that V is a unitary where

$$V_{\beta_2 \circ \alpha_2, \beta_1 \circ \alpha_1} = \begin{cases} \sqrt{\frac{\mu(v_1)\mu(v_3)}{\mu(v_2)\mu(v_4)}} \overline{U}_{\alpha_1 \circ \alpha_2, \beta_1 \circ \beta_2} & \text{if all concatenations are well-defined} \\ 0 & \text{otherwise} \end{cases}$$

for loops $(v_1, \alpha_1, v_2, \alpha_2, v_3, \beta_2, v_4, \beta_1) \in \Omega(A, B, C, D)$. Since V is a unitary we have that

$$\begin{aligned} Z_T(f)(\eta) &= \sum_{\beta_1, \beta_2} \int_{\mathcal{S}} U^* \int_{\mathcal{S}} U = \sum_{\beta_1, \beta_2} \mu(v_5) U(\beta_2 \eta_2 \eta_3 \beta_1) \overline{U(\beta_2 \eta_1 \eta_4 \beta_1)} \\ &= \frac{1}{\sqrt{\mu(v_1)\mu(v_3)}} \sum_{\beta_1, \beta_2} \sqrt{\frac{\mu(v_5)\mu(v_1)}{\mu(v_2)\mu(v_4)}} U_{\beta_2 \circ \eta_2, \beta_1 \circ \eta_3} \sqrt{\frac{\mu(v_5)\mu(v_3)}{\mu(v_2)\mu(v_4)}} \overline{U}_{\beta_2 \circ \eta_1, \beta_1 \circ \eta_4} \\ &= \frac{\delta_{\eta_1 = \eta_2} \delta_{\eta_3 = \eta_4}}{\sqrt{\mu(v_1)\mu(v_3)}} \int_{\mathcal{S}} \end{aligned}$$

□

Now that we have shown U to be a biunitary we introduce a notation to simplify the tangles utilizing this biunitary. We will use the following conventions to interpret crossings



Observe that the four-coloring completely determines how to substitute in U or U^* . Rewriting the biunitary identities using this notation yields the type II Reidemeister moves

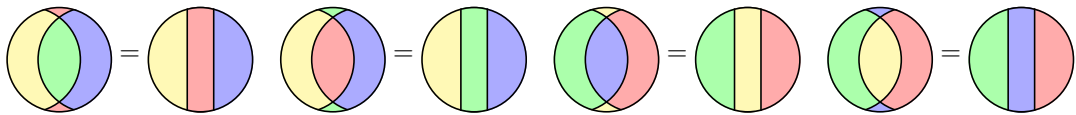

It is tempting to remove the \mathbb{C} inclusion from the colored planar algebra of a symmetric commuting square

since $w - y$ strings do not have loop parameters. This would yield a much better behaved planar algebra but without the \mathbb{C} inclusion the path algebra construction can only build algebras of the form $A' \cap F$ for algebras F in the basic construction of the symmetric commuting square. The planar algebra without the \mathbb{C} inclusion would have the same problem.

$$B \subset C$$

Definition 5.1.10. Let $\begin{array}{ccc} B & \subset & C \\ \cup & & \cup \\ \mathbb{C} & \subset & A \subset D \end{array}$ be a symmetric commuting square with connected inclusions

$$\mathbb{C} \subset A \subset D$$

and let $P^{\mathbb{C}}$ be its colored planar algebra. Define the maps $\psi_U : P^{\mathbb{C}}_{w(yr)^n y} \rightarrow P^{\mathbb{C}}_{wy(gb)^n gy}$ by

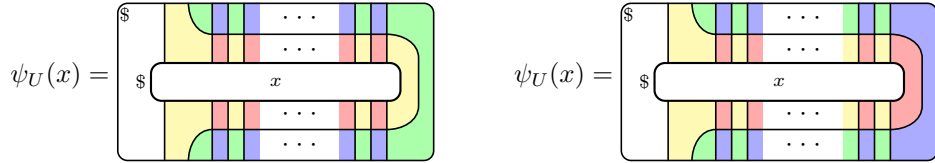

Proposition 5.1.11. The following squares of algebras are isomorphic

$$\begin{array}{ccc} B \subset C & & P^{\mathbb{C}}_{wygy} \subset P^{\mathbb{C}}_{wygbgy} \\ \cup & \cup & \cong \\ \mathbb{C} \subset A \subset D & & P^{\mathbb{C}}_w \subset P^{\mathbb{C}}_{wy} \subset P^{\mathbb{C}}_{wyry} \end{array}$$

with the following inclusions

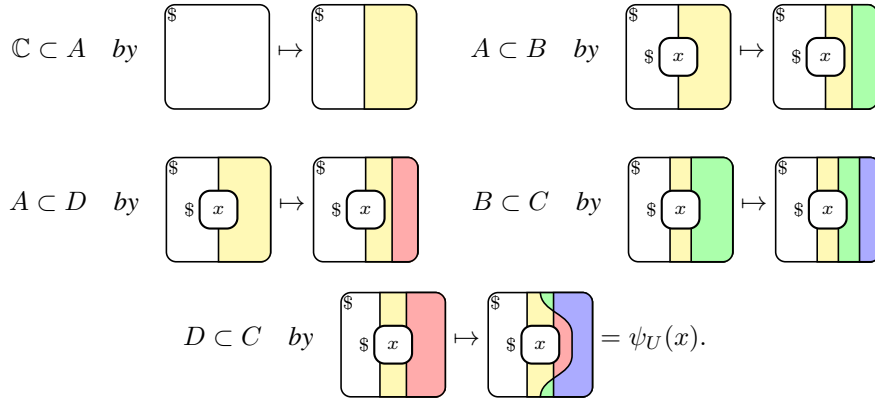

Furthermore, the unique Markov trace is given by capping to the right and dividing by the corresponding loop parameters, i.e. $tr(x) = \frac{\langle x | id \rangle_{\mathbb{C}}}{\langle id | id \rangle_{\mathbb{C}}}$ for $x \in \mathbb{C}, A, B, C,$ or D .

Proof. Each algebra with a sequence of inclusions from \mathbb{C} has a system of matrix units, $\{p_{\alpha, \beta}\}$, from Ocneanu's string algebra construction. Let $\alpha \circ \beta^{-1} \in \mathcal{L}_{\partial}$ then this isomorphism is given by the maps

$p_{\alpha,\beta} \mapsto p \in P_{\partial}^{\mathcal{C}}$ where

$$p(\gamma) = \prod_{v \text{ internal vertices of } \alpha, \beta} \frac{\delta_{\gamma=\alpha\circ\beta^{-1}}}{\sqrt{\mu(v)}}.$$

It is a trivial computation to show that each of these diagrams corresponds to the appropriate inclusions of algebras. The last map given by $D \mapsto \psi_U(D)$ is just a diagrammatic way to write part (iii) of proposition 2.2.6. Finally, $tr(x) = \frac{\langle x | id \rangle_{\mathcal{C}}}{\langle id | id \rangle_{\mathcal{C}}}$ for $x \in \mathbb{C}, A, B, C$, or D follows from a straight forward computation. \square

Proposition 5.1.12. *The basic construction of the symmetric commuting square above is given by the squares*

$$\begin{array}{ccc} P_{wy(gb)^n gy}^{\mathcal{C}} & \subset & P_{wy(gb)^{n+1} gy}^{\mathcal{C}} \\ \cup & & \cup \\ \psi_U(P_{w(yr)^n y}^{\mathcal{C}}) & \subset & \psi_U(P_{w(yr)^{n+1} y}^{\mathcal{C}}) \end{array}$$

Proof. We can show that $P_{w(yr)^{n-1} y}^{\mathcal{C}} \subset P_{w(yr)^n y}^{\mathcal{C}} \subset P_{w(yr)^{n+1} y}^{\mathcal{C}}$ is an instance of the basic construction with the typical diagrams for Jones projections. First, verify that the trace is Markov for the Jones projections to show that $P_{w(yr)^{n+1} y}^{\mathcal{C}}$ contains a basic construction. Then a dimension counting argument will show will show that $P_{w(yr)^{n+1} y}^{\mathcal{C}}$ is the basic construction. Similarly, $P_{wy(gb)^{n-1} gy}^{\mathcal{C}} \subset P_{wy(gb)^n gy}^{\mathcal{C}} \subset P_{wy(gb)^{n+1} gy}^{\mathcal{C}}$ is an instance of the basic construction. The proposition then follows from ψ_U mapping Jones projections of $A \subset D$ to the Jones projections of $B \subset C$, i.e.

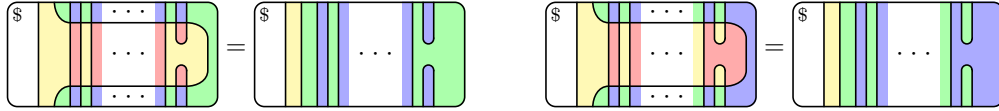

\square

Definition 5.1.13. *Let $N \subset M$ be the horizontal subfactor $\left(\bigcup_n \psi_U(P_{w(yr)^n y}^{\mathcal{C}})\right)'' \subset \left(\bigcup_n P_{wy(gb)^n gy}^{\mathcal{C}}\right)''$ with the Jones tower indexed by $N = M_{-1} \subset M = M_0 \subset M_1 \subset \dots$. Similarly, let $P = R_{-1} \subset R = R_0 \subset R_1 \subset \dots$ be the vertical subfactor and Jones tower.*

Observe that a string cannot cross itself in $P^{\mathcal{C}}$ using the biunitary formalism since such a tangle cannot have four distinct colors at each crossing. The valid four-colorings of vanilla tangles are an important consideration when generalizing results from vanilla or shaded planar algebras. For example, the tunnel construction for spin models does not generalize since the necessary tangles do not admit valid colorings for $P^{\mathcal{C}}$. We will see that flat elements and the angle operator still make sense for $P^{\mathcal{C}}$. We first describe the relative

commutants of the vertical subfactor, $(P_{wygy}^C)' \cap \psi_U(P_{w(yr)^n y}^C)$, then we will construct the angle operator from the conditional expectations to each of these spaces.

Proposition 5.1.14. *The space $(P_{wygy}^C)' \cap P_{wy(gb)^n gy}^C$ can be identified with $P_{(gb)^n}^C$ by the inclusions*

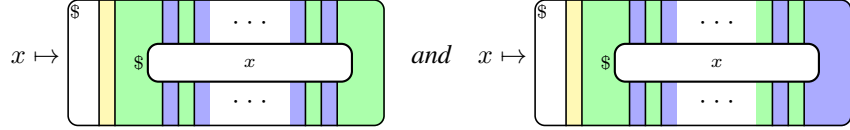

Similarly $(P_{wy}^C)' \cap P_{w(yr)^n y}^C$ can be identified with $P_{(yr)^n}^C$ by the inclusions

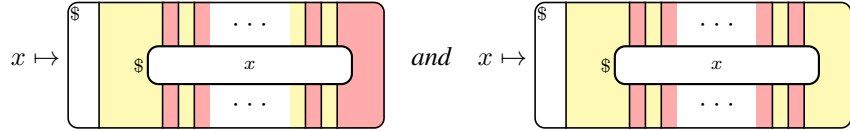

Proof. Certainly all of these elements belong to the commutant. To prove that all elements of the commutant are of this form we need only show the dimensions of $(P_{wygy}^C)' \cap P_{wy(gb)^n gy}^C$ and $P_{(gb)^n}^C$ coincide. Both of these dimensions can be computed by counting the number of pointed oriented loops of length n starting in B in the Bratteli diagram for $B \subset C$. The second claim follows from an identical argument. \square

Corollary 5.1.15. *Since $(P_{wygy}^C)' \cap \psi_U(P_{w(yr)^n y}^C) = (P_{wygy}^C)' \cap P_{wy(gb)^n gy}^C \cap \psi_U((P_{wy}^C)' \cap P_{w(yr)^n y}^C)$ we may now identify the relative commutants of the vertical subfactor as the flat elements in $P_{(yr)^n}^C$, i.e. $x \in P_{(yr)^n}^C$ such that there exists an $y \in P_{(gb)^n}^C$ satisfying*

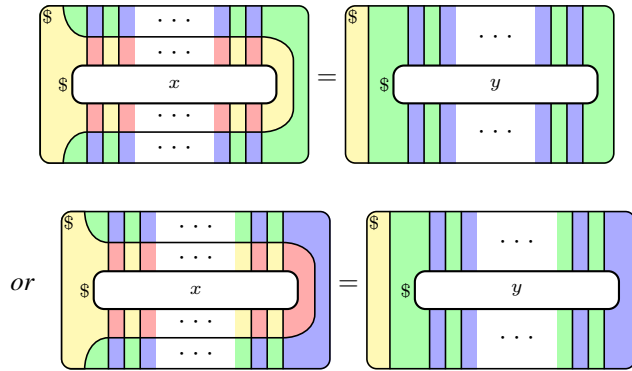

Definition 5.1.16. *Let $P_{(yr)^n}^{flat}, P_y^{flat} \cong P' \cap P$ denote the **flat elements** of $P_{(yr)^n}^C$. We can also exchange the roles of B and D in the commuting square which will switch the roles of the red and green shading. Define $P_{(yg)^n}^{flat}$ as the flat elements of $P_{(yg)^n}^C$ in the same way as above.*

Lemma 5.1.17 (Cable cutting). For each cycle of colors ∂ starting with w set $\lambda_\eta(\gamma) = \sqrt{\mu(\eta)}\delta_{\eta=\gamma} \in P_\partial^C$ for $\eta, \gamma \in \mathcal{L}_\partial$. Then

$$\begin{array}{c}
 \begin{array}{|c|} \hline \$ \\ \hline \lambda_\eta^* \\ \hline \dots \\ \hline \lambda_\gamma \\ \hline \$ \\ \hline \end{array} = \delta_{\eta=\gamma} \\
 \\
 \begin{array}{|c|} \hline \$ \\ \hline \dots \\ \hline \partial \text{ coloring} \\ \hline \end{array} = \sum_{\eta \in \mathcal{L}_\partial} \begin{array}{|c|} \hline \$ \\ \hline \lambda_\eta^* \\ \hline \dots \\ \hline \lambda_\eta \\ \hline \$ \\ \hline \end{array} \text{ for } \eta, \gamma \in P_\partial^C. \\
 \hline \partial \text{ coloring}
 \end{array}$$

Proof. The first equality is easily verified and so $\{\lambda_\eta\}_{\eta \in \mathcal{L}_\partial}$ is an orthonormal basis of P_∂^C . The second equality follows from $\{\lambda_\eta\}_{\eta \in \mathcal{L}_\partial}$ being an orthonormal basis. \square

Definitions 5.1.18. Let $1_{c_1 c_2}$ denote the identity tangle in $P_{c_1 c_2}^C$ for colors c_1 and c_2 . Define the map $1_{c_1 c_2} \otimes: P_{c_2 \partial}^C \rightarrow P_{c_1 c_2 \partial c_2}^C$ by the tangle

$$\xi \mapsto 1_{c_1 c_2} \otimes \xi = \begin{array}{|c|} \hline \$ \\ \hline \xi \\ \hline \$ \\ \hline \end{array}$$

where the coloring of regions is determined by $c_1 c_2 \partial c_2$. For example, given $\xi \in P_{ry}^C$, $1_{yr} \otimes \xi = \begin{array}{|c|} \hline \$ \\ \hline \xi \\ \hline \$ \\ \hline \end{array}$.

We will also use the following conventions for diagrams with parallel strings and alternating shadings. The grey shaded region will stand in for one of the two alternating shadings depending on the parity of n .

$$\begin{array}{ccc}
 \begin{array}{|c|} \hline \eta \\ \hline \end{array} = \begin{array}{|c|} \hline \dots \\ \hline n \text{ strings} \\ \hline \end{array} & \begin{array}{|c|} \hline \eta \\ \hline \end{array} = \begin{array}{|c|} \hline \dots \\ \hline n \text{ strings} \\ \hline \end{array} & \begin{array}{|c|} \hline \eta \\ \hline \end{array} = \begin{array}{|c|} \hline \dots \\ \hline n \text{ strings} \\ \hline \end{array} \\
 \\
 \begin{array}{|c|} \hline \eta \\ \hline \end{array} = \begin{array}{|c|} \hline \dots \\ \hline 2n \text{ strings} \\ \hline \end{array} & \begin{array}{|c|} \hline \eta \\ \hline \end{array} = \begin{array}{|c|} \hline \dots \\ \hline 2n \text{ strings} \\ \hline \end{array} & \begin{array}{|c|} \hline \eta \\ \hline \end{array} = \begin{array}{|c|} \hline \dots \\ \hline 2n \text{ strings} \\ \hline \end{array}
 \end{array}$$

We also need to extend this notation to string crossings. The shadings of the following diagrams are completely determined by the parities of n, k and requiring that every crossing to be adjacent to exactly one region shaded with yellow, green, blue, or red. This allows us to interpret crossings with the biunitary U .

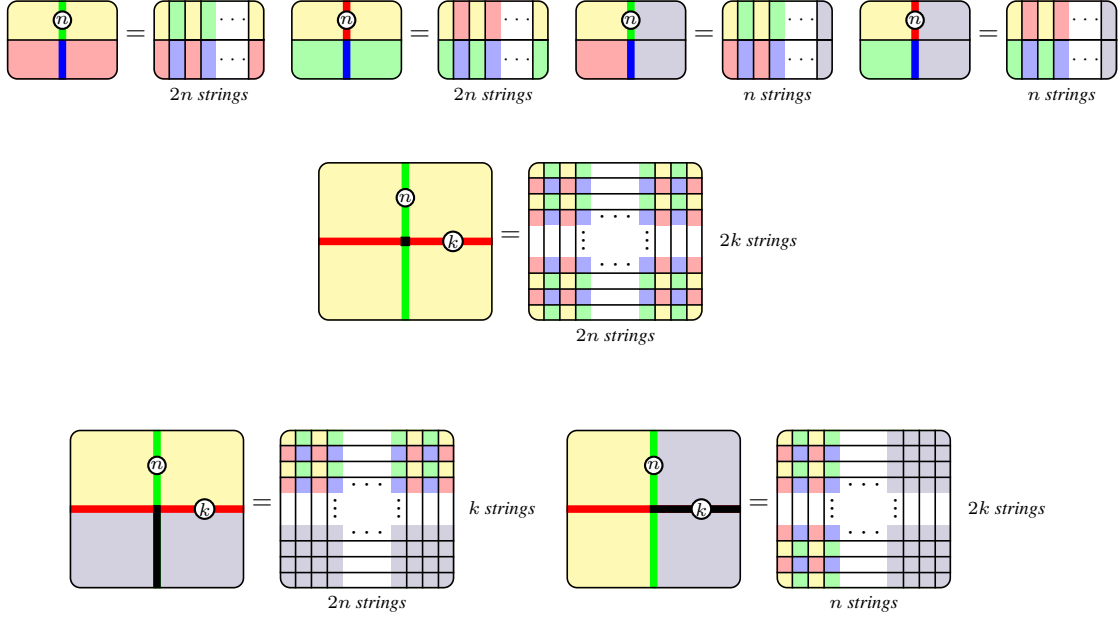

Proposition 5.1.19. Let $N \subset M$ be the horizontal subfactor for the symmetric commuting square above.

Then for $x \in P_{wy(gb)^n gy}^C$,

$$E_N(x) = \frac{1}{\|\Gamma_{ACB}\|} \left[\text{Diagram} \right]$$

Proof. By repeated application of type II Reidemeister moves and the appropriate loop parameters we see that E_N is trace preserving and maps to the correct space. E_N is clearly a projection and restricts to the identity on $\psi_U(P_{wy(ry)^n}^C)$. □

Proposition 5.1.20. Define the linear operator

$$E : \bigcup_n P_{wy(gb)^n gy}^C \rightarrow \nu \left[\bigcup_n (P_{wygy}^C)' \cap P_{wy(gb)^n gy}^C \right] \subset \bigcup_n P_{wy(gb)^n gy}^C$$

by $E(x) = \frac{1}{\|\Gamma_{ACB}\|} \sum_{\eta \in \mathcal{L}_{wygy}} \nu \lambda_\eta x \nu \lambda_\eta^* \in B(L^2(M))$

$$E(x) = \frac{1}{\|\Gamma_{ACB}\|} \left[\text{Diagram} \right] \quad \text{for } x \in P_{wy(gb)^n gy}^C$$

Then E extends uniquely to the orthogonal projection onto $\nu \left[\bigcup_n (P_{wygy}^C)' \cap P_{wy(gb)^n gy}^C \right]^{\|\cdot\|_{tr,2}}$.

Proof. Since E is given by a bounded operator on a dense subspace it must extend uniquely to a bounded operator. We now show that $E^2 = E = E^*$ by verifying their equality on a dense subspace of $L^2(M)$. By reducing loop parameters we can show that $E^2 = E$ and E acts by the identity on $\nu \left[\bigcup_n (P_{wygy}^C)' \cap P_{wy(gb)^n gy}^C \right]$. Using Lemma 5.1.17 we can show that $tr(y^* E(x)) = tr(E(y)^* x)$ which implies that $E^* = E$. \square

Corollary 5.1.21. *Putting these two projections together yields the angle operator $\Theta_U = E_N E E_N$ which is also given by the tangles*

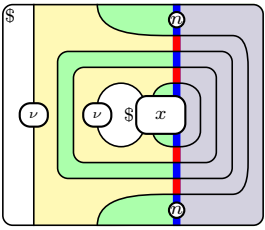
$$\Theta_U(x) = \frac{1}{\|\Gamma^{A \subset B}\|^3} \quad \text{for } x \in P_{wy(gb)^n gy}^C$$

Observe that the eigenspace of $\Theta_U|_{P_{wy(gb)^n gy}^C}$ corresponding to the eigenvalue $\lambda = 1$ is given by

$$\nu \left[\bigcup_n (P_{wygy}^C)' \cap P_{wy(gb)^n gy}^C \right] \cap \psi_U \left(P_{wy(ry)^n}^C \right) = \nu 1_{wy} \otimes P_{(yr)^n}^{flat}$$

since $\nu \in N$ and invertible. Finally, by induction one can show that

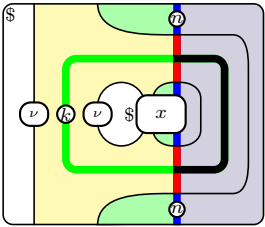
$$\Theta_U^k(x) = \frac{1}{\|\Gamma^{A \subset B}\|^{2k+1}} \quad \text{for } x \in P_{wy(gb)^n gy}^C$$

Definition 5.1.22. *For a biunitary U define the operator*

$$\theta_U: \bigcup_n P_{(yr)^n}^C \rightarrow \bigcup_n P_{(yr)^n}^C$$

by the tangle

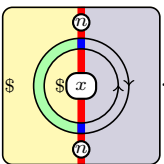
$$\theta_U(x) = \frac{1}{\|\Gamma^{A \subset B}\|^2} \quad \text{for } x \in P_{(yr)^n}^C$$

Observe that $\Theta_U(\nu\psi_U(1_{wy} \otimes x)) = \nu\psi_U(1_{wy} \otimes \theta_U(x))$ where

$$1_{wy} \otimes x = \begin{array}{|c|} \hline \text{\textcircled{\scriptsize ν}} \\ \hline \text{\textcircled{\scriptsize x}} \\ \hline \text{\textcircled{\scriptsize ν}} \\ \hline \end{array} \quad \text{for } x \in P_{(yr)^n}^{\mathcal{C}}.$$

Since ν is invertible, we can equip $\bigcup_n P_{(yr)^n}^{\mathcal{C}}$ with a positive definite inner product,

$$\langle \xi \mid \eta \rangle_{yr} = \langle \nu\psi_U(1_{wy} \otimes \xi) \mid \nu\psi_U(1_{wy} \otimes \eta) \rangle_{tr},$$

and take its completion, $H_{yr} = \overline{\bigcup_n P_{(yr)^n}^{\mathcal{C}}}^{\langle \cdot \mid \cdot \rangle_{yr}}$. This gives a representation of θ_U on H_{yr} that is unitarily equivalent to Θ_U represented on $\overline{\nu\psi_U \left[\left(1_{wy} \otimes \bigcup_n P_{(yr)^n}^{\mathcal{C}} \right) \right]}^{\langle \cdot \mid \cdot \rangle_{tr}}$. This is the Hilbert space θ_U will be represented on when we consider the spectrum of θ_U at the end of this chapter.

Observe that $\xi \in P_{(yr)^n}^{\mathcal{C}}$ is flat iff ξ is in the 1-eigenspace of θ_U . The angle operator extends the notion of flatness to $P_{(ry)^n}^{flat}$ and P_r^{flat} . We call $\xi \in P_{(ry)^n}^{\mathcal{C}}$ (resp. $\xi \in P_r^{\mathcal{C}}$) flat if $1_{yr} \otimes \xi$ belongs to the 1-eigenspace of θ_U . $P_r^{flat} \cong \mathbb{C}$ is an immediate consequence of Perron Frobenius theory applied to $\Gamma^{ACD}(\Gamma^{ACD})^*$.

Remark 5.1.23. *All of the analysis above could have been done with B and D switched. This would exchange the roles of the biunitaries U and U^* , the subfactors $N \subset M$ and $P \subset R$, and the shadings, red and green. Let ψ_{U^*} and Θ_{U^*} denote the maps corresponding to ψ_U and Θ_U in the construction above. The planar diagrams defining them can be obtained from exchanging red and green shading.*

Definition 5.1.24. *Define the shaded planar algebra, $P^{flat,yr}$, by $P_{n,+}^{flat,yr} = P_{(yr)^n}^{flat}$, $P_{n,-}^{flat,yr} = P_{(ry)^n}^{flat} = \rho(P_{(yr)^n}^{flat})$, $P_{0,+}^{flat,yr} = P_y^{flat} \cong \mathbb{C}$, and $P_{0,-}^{flat,yr} = P_r^{flat} \cong \mathbb{C}$. The action of shaded tangles on $P^{flat,yr}$ is given by replacing unshaded regions by a yellow shading, shaded regions by a red shading, and using the action in $P^{\mathcal{C}}$ by colored planar tangles.*

Proposition 5.1.25. *$P^{flat,yr}$ is a subfactor planar algebra.*

Proof. $P^{flat,yr}$ is a unital planar subalgebra of $P_{(yr)^n}^{\mathcal{C}}$ by the same argument as the proof for theorem 3.2.4 where $P_{(yr)^n}^{\mathcal{C}}$ is the colored planar algebra obtained by restricting to yellow and red shadings. $P^{flat,yr}$ is a C^* planar algebra as it is a $*$ -closed planar subalgebra of $P_{(yr)^n}^{\mathcal{C}}$ which is a C^* planar algebra. Finally, we must verify that $P^{flat,yr}$ is spherical. This easily follows from the properties of flat elements, loop parameters, ν , and the cable cutting procedure. \square

We now show that $P^{flat,yr}$ is isomorphic to the vertical subfactor planar algebra P^{PCR} . First we must

compute more general conditional expectations in the grid of algebras generated by the initial symmetric commuting square.

Lemma 5.1.26. *Let $A = A_{0,0}$, $D = A_{1,0}$, $B = A_{0,1}$ and $C = A_{1,1}$. Then let $A_{i,j}$, $i, j \in \mathbb{N}$ be the grid of algebras obtained from the basic construction of the symmetric commuting square. Then $A_{n,2m} \cong P_{wy(gy)^m(ry)^n(gy)^m}^C$ and $A_{n,2m+1} \cong P_{wy(gy)^m g(bg)^n(yg)^m y}^C$ for $n, m \in \mathbb{N}$. Furthermore, we have the inclu-*

$$A_{0,m} \subset A_{n,m}$$

sions and conditional expectations for the square $\cup \quad \cup$.

$$A_{0,0} \subset A_{n,0}$$

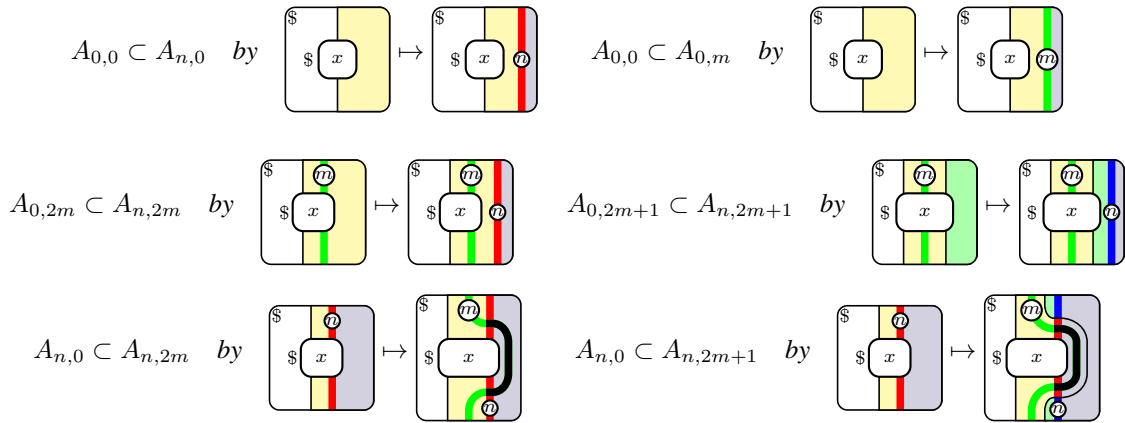

$E_{A_{0,m}}^{A_{n,m}}(x)$ is obtained from capping off the right n strings and normalizing by the appropriate product of loop parameters. Similarly, $E_{A_{n,0}}^{A_{n,m}}(x)$ is obtained from capping off the middle m strings to the right using the biunitary for string crossings and normalizing by the appropriate product of loop parameters.

Proof. The isomorphisms of algebras follows from Ocneanu's string algebra construction. We have already

$$A_{0,1} \subset A_{n,1}$$

proven these inclusions for $\cup \quad \cup$. We proceed by induction. Suppose we have shown this result

$$A_{0,0} \subset A_{n,0}$$

for $m \geq 1$, then for n, m even we have the inclusion map $A_{n,0} \subset A_{n,m} \subset P_{wy(gy)^{m/2}(ry)^{n/2}gy(ry)^{n/2}(gy)^{m/2}}^C$ by adding one string to the right. To get the appropriate embedding into $A_{n,m+1}$ we must conjugate by the biunitaries U and V to obtain an element in $A_{n,m+1}$. This yields the inclusions provided here. The other cases are identical but correspond to slightly different shadings. Since capping all strings to the right and renormalizing yields a coherent trace by type II Reidemeister, it must be the unique trace on this grid of algebras. The tangle for $E_{A_{0,m}}^{A_{n,m}}$ (resp. $E_{A_{n,0}}^{A_{n,m}}$) then follows from the defining equality $tr(E_{A_{0,m}}^{A_{n,m}}(y)x) = tr(yx)$ (resp. $tr(E_{A_{n,0}}^{A_{n,m}}(y)x) = tr(yx)$) for all $y \in A_{n,m}$ and $x \in A_{0,m}$ (resp. $x \in A_{n,0}$). \square

Lemma 5.1.27. $\{[R_{n-1} : P]^{1/4} \lambda_\eta \nu\}_{\eta \in \mathcal{L}_{wy}(ry)^n}$ is an orthonormal basis of $P \subset R_{n-1}$, i.e.

$$x = [R_{n-1} : P]^{1/2} \sum_{\eta \in \mathcal{L}_{wy}(ry)^n} \lambda_\eta \nu E_P(\nu \lambda_\eta^* x) \text{ for } x \in R_{n-1}.$$

Proof. Using the previous lemma, we can verify that $\{[R_{n-1} : P]^{1/4} \lambda_\eta \nu\}_{\eta \in \mathcal{L}_{wy}(ry)^n}$ is a basis of the square

$$\begin{array}{ccc} A_{0,m} & \subset & A_{n,m} \\ \cup & & \cup \text{ for every } m \text{ and so by strong convergence of } E_{A_{0,m}}^{A_{n,m}} \text{ to } E_P \text{ the result follows.} \\ A_{0,0} & \subset & A_{n,0} \end{array} \quad \square$$

Proposition 5.1.28. $P^{PCR} \cong P^{flat,yr}$.

Proof. We already have an identification of P^{PCR} with $P^{flat,yr}$ by Ocneanu compactness. We have shown this identification preserves the C^* -algebra structures, Temperley-Lieb subalgebras, inclusions, and conditional expectations of P^{PCR} and $P^{flat,yr}$. It suffices to show the generating tangles defined for theorem 3.2.4 act on P^{PCR} and $P_{(yr)^n}^{flat}$ identically. Since multiplication, Temperley-Lieb, inclusion, and conditional expectation tangles act identically on these planar algebras, it suffices to check that rotation tangles do as well. We will show that the rotation tangle, ρ^{2k} , acts on $P_{2k,+}^{PCR}$ and $P_{(yr)^{2k}}^{flat}$ identically. In [Bis97] ρ^{2k} is also called the surjective anti-isomorphism $\gamma_k: P' \cap R_{2k+1} \rightarrow P' \cap R_{2k+1}$, $\pi_k(\gamma_k(x)) = J_k \pi_k(x)^* J_k$ and is computed algebraically using basis' of the Jones tower. Let $P \subset R_{k-1} \subset^{f_{k-1}} R_{2k-1}$ and fix $x \in P_{(yr)^{2k}}^{flat}$, then by Lemma 5.1.17

$$\begin{aligned} \gamma_{k-1}(x) &= [R_{k-1} : P]^{3/2} \sum_{\eta \in \mathcal{L}_{wy}(ry)^k} E_{R_{k-1}}(f_{k-1} \lambda_\eta \nu x) f_{k-1} \nu \lambda_\eta^* \\ &= \sum_{\eta \in \mathcal{L}_{wy}(ry)^k} \left[\text{Diagram 1} \right] = \left[\text{Diagram 2} \right] = \left[\text{Diagram 3} \right]. \end{aligned}$$

Since this is the same tangle for γ_k in $P_{2k,+}^{PCR}$ this concludes the claim. The rotation tangle, ρ^2 , may then be constructed from ρ^{2k} , Temperley-Lieb elements, and conditional expectations. This allows all generating tangles to be constructed and so these planar algebras coincide. \square

The same analysis can be done for the flat elements in $P_{(yg)^n}^C$ yielding the subfactor planar algebra for $N \subset M$ which we denote $P^{flat,yg}$. Since $P_{0,\pm}^{flat,yg} \cong \mathbb{C} \cong P_{0,\pm}^{flat,yr}$ and $P^{flat,yr}$, $P^{flat,yg}$ are spherical, they have natural inner products, $\langle \cdot | \cdot \rangle_{flat,yr}$, and $\langle \cdot | \cdot \rangle_{flat,yg}$ given by the tangles

$$\langle x | y \rangle_{flat, yr} = \begin{array}{c} \$ \\ \text{---} \\ \$ \end{array} \begin{array}{c} \$ \\ y^* \\ \text{---} \\ x \\ \$ \end{array} \quad \text{and} \quad \langle x | y \rangle_{flat, yg} = \begin{array}{c} \$ \\ \text{---} \\ \$ \end{array} \begin{array}{c} \$ \\ y^* \\ \text{---} \\ x \\ \$ \end{array}.$$

5.2 Operators in $C^*(M, e_N, JBJ)$

Since $L^2(M)$ comes with a dense graded subspace, $\bigcup_n P_{wy(gb)^n gy}^C$, and e_N, B , and JBJ preserve the grading, we can perform computations in $Alg(B, e_N, JBJ)$ by confirming equality when acting on $P_{wy(gb)^n gy}^C$ for every n .

Definition 5.2.1. Fix $k \in \mathbb{N}$, $x, y \in P_{w(yg)^k y}^C$ and define the operator $\pi_{x,y} \in B(L^2(M))$ by the following action on the dense subspace $\bigcup_n P_{wy(gb)^n gy}^C$.

$$\pi_{x,y} \xi = \frac{1}{\|\Gamma^{ACB}\|} \begin{array}{c} \$ \\ \text{---} \\ \$ \end{array} \begin{array}{c} \$ \\ x \\ \text{---} \\ \mathbb{C} \\ \text{---} \\ y^* \\ \$ \end{array} \xi \quad \text{for } \xi \in P_{wyg(bg)^n y}^C.$$

Remark 5.2.2. Observe that $\pi_{x,y}$ commutes with the inclusion maps for $\bigcup_n P_{wy(gb)^n gy}^C$ due to type II Reidemeister moves.

Lemma 5.2.3. For all $x, y \in P_{w(yg)^k y}^C$, $\pi_{x,y} \in e_N Alg(B, e_N, JBJ) e_N$ and in particular $\pi_{x,y}$ is a bounded operator on $L^2(M)$.

Proof. For each vertex $v \in V(\Gamma^A)$ fix an edge $e_v \in E(\Gamma^{C \subset A})$ connecting \mathbb{C} to v . We will proceed by induction. For $x, y \in P_{wygy}^C$, $\pi_{x,y} = \|\Gamma^{ACB}\| e_N x(JyJ) e_N$. Assume that $\pi_{x,y} \in e_N Alg(B, e_N, JBJ) e_N$ for $x, y \in P_{w(yg)^k y}^C$. Fix two $w(yg)^{k+1}y$ loops

$$\gamma = \tilde{\gamma} \circ (v_{1,y}, e_1, v_{2,g}, e_2, v_{3,y}, e_3, v_{\mathbb{C}})$$

$$\sigma = \tilde{\sigma} \circ (u_{1,y}, f_1, u_{2,g}, f_2, u_{3,y}, f_3, v_{\mathbb{C}})$$

where $\tilde{\gamma}$ and $\tilde{\sigma}$ are $w(yg)^n y$ paths. Define the loops

$$\gamma_1 = \tilde{\gamma} \circ (v_{1,y}, e_{v_{1,y}}, v_{\mathbb{C}}) \quad \gamma_2 = (v_{\mathbb{C}}, e_{v_{1,y}}, v_{1,y}, e_1, v_{2,g}, e_2, v_{3,y}, e_3, v_{\mathbb{C}})$$

$$\sigma_1 = \tilde{\sigma} \circ (u_{1,y}, e_{u_{1,y}}, v_{\mathbb{C}}) \quad \sigma_2 = (v_{\mathbb{C}}, e_{u_{1,y}}, u_{1,y}, f_1, u_{2,g}, f_2, u_{3,y}, f_3, v_{\mathbb{C}}).$$

For $x, y \in P_{w(yg)^{k+1}y}^C$, $x(\alpha) = \delta_{\alpha=\gamma}$, $y(\alpha) = \delta_{\alpha=\sigma}$ define $x_i(\alpha) = \delta_{\alpha=\gamma_i}$, $y_i(\alpha) = \delta_{\alpha=\sigma_i}$ for $i = 1, 2$. Then $\pi_{x,y} = \|\Gamma^{A \subset B}\| \pi_{x_1, y_1} e_N x_2 (J y_2 J) e_N$. Thus $\pi_{x,y} \in e_N \text{Alg}_{L^2(M)}(B, e_N, J B J) e_N$ for x, y in a basis of $P_{w(yg)^{k+1}y}^C$ and so our inductive step is proved. \square

5.3 A Representation of the Fusion Algebra

Since we have a large collection of elements from $C^*(M, e_N, J M J)$ that are definable using the planar algebra P^C , we may construct interesting maps and perform computations with planar algebra techniques. We now define a representation of the fusion algebra, $\mathcal{F}(N \subset M)$, in a corner of $C^*(M, e_N, J M J)$.

Definition 5.3.1. For each irreducible $N - N$ bimodule, α , of the $N \subset M$ fusion algebra let p_α be a minimal projection in $P_{(yg)^{2k}}^{flat}$ for some $k \in \mathbb{N}$ corresponding to α . Define the linear operator $\Phi(\alpha): \bigcup_n P_{wyg(bg)^n y}^C \rightarrow \bigcup_n P_{wyg(bg)^n y}^C$ by

$$\Phi(\alpha)\xi = \frac{1}{\|\Gamma^{A \subset B}\|} \sum_{\eta \in \mathcal{L}_{wyg(bg)^k}} \text{Diagram} \quad \text{for } \xi \in P_{wyg(bg)^n y}^C$$

Since $\Phi(\alpha)$ is a finite sum of $\pi_{x,y}$'s it must extend uniquely to a bounded operator in $C^*(M, e_N, J M J)$.

Proposition 5.3.2. Φ has the following properties.

- (i) Φ is independent of the choice of p_α .
- (ii) $\Phi(\alpha)^* = \Phi(\bar{\alpha})$.
- (iii) $\Phi(\alpha)\Phi(\beta) = \sum_{\gamma \in \Gamma_{even}^{N \subset M}} N_{\alpha, \beta}^\gamma \Phi(\gamma)$.

Proof. We will prove these equalities on the dense subspace $\bigcup_n P_{wyg(bg)^n y}^C \subset L^2(M)$ which implies they hold on $L^2(M)$. We first show that $\Phi(\alpha)$ is independent of the choice of minimal projections. If $p \sim p_\alpha$ in the projection category then there exists a partial isometry $w \in P_{(yg)^{k+m}}^{flat}$ such that

$$p_\alpha = \text{Diagram 1} \quad \text{and} \quad p = \text{Diagram 2}$$

Since w is flat and by Lemma 5.1.17

$$\Phi(\alpha)\xi = \frac{1}{\|\Gamma_{ACB}\|} \left[\text{Diagram 1} \right] = \frac{1}{\|\Gamma_{ACB}\|} \left[\text{Diagram 2} \right]$$

for $\xi \in P_{wyg(bg)^{n_y}}^C$. To prove part (ii) apply Lemma 5.1.17 to $\langle \xi | \Phi(\alpha)\eta \rangle$ for $\xi, \eta \in P_{wyg(bg)^{n_y}}^C$ and observe that

$$\Phi(\alpha)^*\xi = \frac{1}{\|\Gamma_{ACB}\|} \left[\text{Diagram 1} \right] = \frac{1}{\|\Gamma_{ACB}\|} \left[\text{Diagram 2} \right] = \Phi(\bar{\alpha})\xi$$

since

$$p_{\bar{\alpha}} \sim \left[\text{Diagram} \right]$$

For part (iii) observe that

$$\Phi(\alpha)\Phi(\beta)\xi = \frac{1}{\|\Gamma_{ACB}\|} \left[\text{Diagram 1} \right] = \sum_{\gamma \in \Gamma_{\text{even}}^{NCM}} N_{\alpha, \beta}^{\gamma} \Phi(\gamma)\xi$$

for $\xi \in P_{wyg(bg)^n y}^C$, since

$$\begin{array}{|c|} \hline \$ \\ \hline \begin{array}{|c|} \hline \zeta \\ \hline \end{array} \begin{array}{|c|} \hline \eta \\ \hline \end{array} \\ \hline \begin{array}{|c|} \hline p_\alpha \\ \hline \end{array} \begin{array}{|c|} \hline p_\beta \\ \hline \end{array} \\ \hline \$ \\ \hline \end{array} = \sum_{i \in I} p_i$$

where $p_i \in P_{(yg)^{2k+2m}}^{flat}$ are mutually orthogonal minimal projections in $P_{(yg)^{2k+2m}}^{flat}$ and exactly $N_{\alpha, \beta}^\gamma$ of $\{p_i\}_{i \in I}$ are equivalent to p_γ for each $N - N$ bimodule γ . \square

5.4 Computation of τ

Due to Popa in [Pop99] if $N \subset M$ is an extremal finite index subfactor then there exists a unique tracial state on $C^*(M, e_N, JMJ)$ which is faithful iff $N \subset M$ is amenable. By [Bur10] all symmetric commuting square subfactors are extremal. Thus we can use Popa's construction. In this section we will use the cyclic invariance of M and JMJ of this trace to compute the value of the trace on the image of Φ .

Lemma 5.4.1. *Let $\{\xi_i\}_{i \in I}$ and $\{\zeta_i\}_{i \in I}$ be two orthonormal basis's of $P_{wy(gy)^n}^C$ with respect to $\langle \cdot | \cdot \rangle_C$. Then*

$$W = \sum_i \begin{array}{|c|} \hline \$ \\ \hline \begin{array}{|c|} \hline \zeta_i \\ \hline \end{array} \begin{array}{|c|} \hline \xi_i^* \\ \hline \end{array} \\ \hline \$ \\ \hline \end{array}$$

is a unitary in $P_{wy(gy)^n wy(gy)^n}^C$ sending ξ_i to ζ_i for every $i \in I$.

Lemma 5.4.2. *Fix $k, l \in \mathbb{N}$ and let $x, y \in P_{y(gy)^k}^C$. Define the linear operator*

$$\rho_{x,y,l}: \bigcup_n P_{wyg(bg)^{2l+n}y}^C \rightarrow \bigcup_n P_{wyg(bg)^{2l+n}y}^C$$

$$\rho_{x,y,l} \xi = \begin{array}{|c|} \hline \$ \\ \hline \begin{array}{|c|} \hline \begin{array}{|c|} \hline x \\ \hline \end{array} \\ \hline \end{array} \begin{array}{|c|} \hline \begin{array}{|c|} \hline \zeta \\ \hline \end{array} \\ \hline \end{array} \\ \hline \begin{array}{|c|} \hline \begin{array}{|c|} \hline y^* \\ \hline \end{array} \\ \hline \end{array} \\ \hline \$ \\ \hline \end{array} \xi \quad \text{for } \xi \in P_{wyg(bg)^{2l+n}y}^C$$

Then

$$\|\rho_{x,y,l}\|_{B(L^2(M))} \leq \left\| \begin{array}{|c|} \hline \$ \\ \hline \begin{array}{|c|} \hline x \\ \hline \end{array} \\ \hline \begin{array}{|c|} \hline \zeta \\ \hline \end{array} \\ \hline \begin{array}{|c|} \hline x^* \\ \hline \end{array} \\ \hline \$ \\ \hline \end{array} \right\|_{B' \cap B}^{1/2} \left\| \begin{array}{|c|} \hline \$ \\ \hline \begin{array}{|c|} \hline y \\ \hline \end{array} \\ \hline \begin{array}{|c|} \hline \zeta \\ \hline \end{array} \\ \hline \begin{array}{|c|} \hline y^* \\ \hline \end{array} \\ \hline \$ \\ \hline \end{array} \right\|_{B' \cap B}^{1/2}.$$

Proof. We will verify this inequality by obtaining an upper bound of $|\langle \rho_{x,y,l} \xi \mid \eta \rangle_C|$ for ξ and η in a dense subset of $L^2(M)$. Let $\xi, \eta \in P_{wyg(bg)^{2l+n_y}}^C$, then due to the Cauchy-Schwarz inequality and unitarity of the first diagram below

$$|\langle \rho_{x,y,l} \xi \mid \eta \rangle_C| = \left| \begin{array}{c} \text{Diagram 1} \\ \text{Diagram 2} \\ \text{Diagram 3} \end{array} \right|_C$$

$$\leq \left| \begin{array}{c} \text{Diagram 4} \\ \text{Diagram 5} \end{array} \right|^{1/2} \left| \begin{array}{c} \text{Diagram 6} \\ \text{Diagram 7} \end{array} \right|^{1/2} \leq \left| \begin{array}{c} \text{Diagram 8} \\ \text{Diagram 9} \end{array} \right|^{1/2} \left| \begin{array}{c} \text{Diagram 10} \\ \text{Diagram 11} \end{array} \right|^{1/2} = \|\xi\|_C \|\eta\|_C.$$

The last inequality follows since the operator norm is unique for the C^* -algebra, $B' \cap B$. Renormalizing by the appropriate loop parameters yields

$$|\langle \rho_{x,y,l} \xi \mid \eta \rangle_{tr}| \leq \left| \begin{array}{c} \text{Diagram 12} \\ \text{Diagram 13} \end{array} \right|_{B' \cap B}^{1/2} \left| \begin{array}{c} \text{Diagram 14} \\ \text{Diagram 15} \end{array} \right|_{B' \cap B}^{1/2} = \|\xi\|_{tr} \|\eta\|_{tr},$$

and so the result follows. \square

Lemma 5.4.3. $\sum_{\eta \in \mathcal{L}_{wyg(bg)^{2n_y}}} \lambda_\eta \nu^2 \lambda_\eta^* = \|\Gamma^{A \subset B}\| \cdot \|\Gamma^{B \subset C}\|^{2n} \cdot id_M.$

Proof. Use Lemma 5.1.17 to remove the summation and the λ_η 's, then use loop parameters to remove homologically trivial loops. \square

Lemma 5.4.4. Let τ denote the unique tracial state on $C^*(M, e_N, JMJ)$. Then for $a, b \in P_{wy(gy)^k}^C$

$$\tau(\nu\pi_{a,b}(J\nu J)) = \frac{\tau(\nu^2(J\nu^2 J)\rho_{x,y,l})}{\|\Gamma_{ACB}\|^3 \cdot \|\Gamma_{BCC}\|^2} \text{ where}$$

$$x = \left[\begin{array}{c} \text{---} \nu \text{---} \\ \text{---} \nu \text{---} \end{array} \right] \Theta_{U^*}^l(\psi_{U^*}(a)) \left[\begin{array}{c} \text{---} \nu \text{---} \\ \text{---} \nu \text{---} \end{array} \right] \text{ and } y = \left[\begin{array}{c} \text{---} \nu \text{---} \\ \text{---} \nu \text{---} \end{array} \right] \Theta_{U^*}^l(\psi_{U^*}(b)) \left[\begin{array}{c} \text{---} \nu \text{---} \\ \text{---} \nu \text{---} \end{array} \right].$$

Furthermore, if $a = 1_{yg} \otimes a'$, $b = 1_{yg} \otimes b'$ for $a', b' \in P_{(yg)^k}^{flat}$ then $\tau(\nu\pi_{a,b}(J\nu J)) = \frac{tr_N(\nu^2)^2}{\|\Gamma_{ACB}\|^2} \langle a | b \rangle_{flat,yg}$.

Proof. Since τ is M and JMJ invariant,

$$\begin{aligned} \tau(\nu\pi_{a,b}(J\nu J)) &= \sum_{\eta, \gamma \in \mathcal{L}_{wyg(bg)^{2l_y}}} \frac{\tau(\nu\pi_{a,b}(J\nu J)\lambda_\eta \nu^2 \lambda_\eta^* (J\lambda_\gamma \nu^2 \lambda_\gamma^* J))}{\|\Gamma_{ACB}\|^2 \cdot \|\Gamma_{BCC}\|^{4l}} \\ &= \tau \left(\sum_{\eta, \gamma \in \mathcal{L}_{wyg(bg)^{2l_y}}} \frac{(J\nu\lambda_\gamma^* J)\nu\lambda_\eta^* \nu\pi_{a,b}(J\nu J)\lambda_\eta \nu (J\lambda_\gamma \nu J)}{\|\Gamma_{ACB}\|^2 \cdot \|\Gamma_{BCC}\|^{4l}} \right). \end{aligned}$$

Now consider the action of the operator above on $L^2(M)$. For $\xi \in \bigcup_k P_{wyg(bg)^{4l+2n_y}}^C$

$$\begin{aligned} &\sum_{\eta, \gamma \in \mathcal{L}_{wyg(bg)^{2l_y}}} \frac{(J\nu\lambda_\gamma^* J)\nu\lambda_\eta^* \nu\pi_{a,b}(J\nu J)\lambda_\eta \nu (J\lambda_\gamma \nu J)}{\|\Gamma_{ACB}\|^2 \cdot \|\Gamma_{BCC}\|^{4l}} (\xi) \\ &= \sum_{\eta, \gamma \in \mathcal{L}_{wyg(bg)^{2l_y}}} \frac{1}{\|\Gamma_{ACB}\|^3 \cdot \|\Gamma_{BCC}\|^{4l}} \left[\begin{array}{c} \nu \quad \nu \quad \nu \quad \nu \quad \nu \quad \nu \\ \text{---} \lambda_\eta^* \text{---} \quad \text{---} a \text{---} \quad \text{---} \lambda_\eta \text{---} \quad \nu \\ \text{---} \nu \text{---} \quad \text{---} \nu \text{---} \quad \text{---} \nu \text{---} \quad \text{---} \nu \text{---} \\ \text{---} \lambda_\gamma \text{---} \quad \text{---} b^* \text{---} \quad \text{---} \lambda_\gamma^* \text{---} \quad \nu \\ \nu \quad \nu \quad \nu \quad \nu \quad \nu \quad \nu \end{array} \right] \xi \\ &= \frac{1}{\|\Gamma_{ACB}\|^3 \cdot \|\Gamma_{BCC}\|^{4l}} \left[\begin{array}{c} \nu \quad \nu \\ \text{---} \nu \text{---} \\ \text{---} \nu \text{---} a \text{---} \nu \text{---} \\ \text{---} \nu \text{---} b^* \text{---} \nu \text{---} \\ \text{---} \nu \text{---} \\ \nu \quad \nu \end{array} \right] \xi = \frac{\nu^2(J\nu^2 J)\rho_{x,y,l}(\xi)}{\|\Gamma_{ACB}\|^3 \cdot \|\Gamma_{BCC}\|^2} \end{aligned}$$

with respect to $\langle \cdot | \cdot \rangle_{\mathcal{C}}$ and χ is a multiple of $1_{wy} \otimes x$. Then by Lemma 5.4.1

$$\Phi(\alpha)\Phi(\beta)^*\xi = \frac{1}{\|\Gamma_{ACB}\|} \sum_{\eta \in \mathcal{L}_{wy(gy)^{k+m}}} \text{Diagram}(\eta)$$

$$= \frac{1}{\|\Gamma_{ACB}\|} \text{Diagram}(\chi) + \frac{1}{\|\Gamma_{ACB}\|} \sum_{i \in I} \text{Diagram}(\eta'_i) + \frac{1}{\|\Gamma_{ACB}\|} \sum_{j \in J} \text{Diagram}(\zeta_j)$$

for $\xi \in P_{wyg(bg)^{k_y}}^{\mathcal{C}}$. Let $\chi = 1_{wy} \otimes \chi'$ and $\eta_i = 1_{wy} \otimes \eta'_i$ for $\chi', \eta'_i \in P_{(yg)^{k+m}}^{flat}$. Define

$$a_x = \text{Diagram}(\chi'), \quad b_x = \text{Diagram}(\chi', p_\beta), \quad a_i = \text{Diagram}(p_\alpha, \eta'_i), \quad b_i = \text{Diagram}(\eta'_i, p_\beta)$$

$$a_j = \text{Diagram}(p_\alpha, \zeta_j), \quad b_j = \text{Diagram}(\zeta_j, p_\beta)$$

and observe that

$$\tau(\Phi(\alpha)\Phi(\beta)^*) = \tau(\nu\pi_{\nu a_x, \nu b_x}(J\nu J)) + \sum_{i \in I} \tau(\nu\pi_{\nu a_i, \nu b_i}(J\nu J)) + \sum_{j \in J} \tau(\nu\pi_{\nu a_j, \nu b_j}(J\nu J)).$$

Since $\lim_{l \rightarrow \infty} \Theta_{U^*}^l(\psi_{U^*}(\nu\zeta_j)) = 0$, by Lemma 5.4.2, $\lim_{l \rightarrow \infty} \|\rho_{y,z,l}\| = 0$ where

$$y = \text{Diagram}(\Theta_{U^*}^l(\psi_{U^*}(\nu a_j))) \quad \text{and} \quad z = \text{Diagram}(\Theta_{U^*}^l(\psi_{U^*}(\nu b_j)))$$

Thus, by operator norm continuity of τ and Lemma 5.4.4, $\tau(\nu\pi_{\nu a_j, \nu b_j}(J\nu J)) = 0$. Finally,

$$\tau(\Phi(\alpha)\Phi(\beta)^*) = \frac{\text{tr}_N(\nu^2)^2}{\|\Gamma_{ACB}\|^2} \left(\langle a_x | b_x \rangle_{\mathcal{C}} + \sum_{i \in I} \langle a_i | b_i \rangle_{\mathcal{C}} \right) = \frac{\text{tr}_N(\nu^2)^2}{\|\Gamma_{ACB}\|^2} \langle \chi | \chi \rangle_{\mathcal{C}} = \frac{\text{tr}_N(\nu^2)}{\|\Gamma_{ACB}\|^2}.$$

where the last equation follows from

$$1 = \left[\begin{array}{c} \text{\$} \\ \text{\$} \chi'^* \text{\$} \chi' \text{\$} \\ \text{\$} \end{array} \right] = \langle \chi' \mid \chi' \rangle_{flat, yg} tr_N(\nu^2) = \langle \chi \mid \chi \rangle_C tr_N(\nu^2)$$

If $p_\alpha \approx p_\beta$ then we can perform the exact same calculation except there is no nontrivial $\chi \in Mor(p_\alpha, p_\beta)$. Thus $\tau(\Phi(\alpha)\Phi(\beta)^*) = 0$. \square

Theorem 5.4.6. *Let $C^*(N \subset M)$ be the C^* -algebra generated by the fusion algebra, $\mathcal{F}(N \subset M)$, in the GNS representation associated with $\phi(\alpha) = \dim(\text{Hom}(\alpha, id))$. Then*

$$\tilde{\Phi}: \mathcal{F}(N \subset M) \rightarrow e(C^*(M, e_N, JMJ)/\mathcal{I}_\tau)e,$$

$\tilde{\Phi}(\alpha) = \Phi(\alpha) + \mathcal{I}_\tau$, is a unital norm preserving $*$ -homomorphism where $e = \tilde{\Phi}(id)$, hence $\tilde{\Phi}$ extends to a unital norm preserving $*$ -homomorphism $\tilde{\Phi}: C^*(N \subset M) \rightarrow e(C^*(M, e_N, JMJ)/\mathcal{I}_\tau)e$.

Proof. Let $\mathcal{S} = e(C^*(M, e_N, JMJ)/\mathcal{I}_\tau)e$ denote the corner C^* -algebra and define the faithful continuous linear functional $\tilde{\tau}: \mathcal{S} \rightarrow \mathbb{C}$ by $\tilde{\tau}(e(x+\mathcal{I}_\tau)e) = \frac{\|\Gamma^{A \subset B}\|^2}{tr_N(\nu^2)} \tau(exe)$. Then $\tilde{\tau}$ is a normalized faithful tracial state. Proposition 5.3.2 and proposition 5.4.5 imply that $\tilde{\Phi}$ is a $*$ -homomorphism such that $\phi(x) = \tilde{\tau}(\tilde{\Phi}(x))$ for any $x \in \text{span}\{\alpha \mid \text{irreducible } N - N \text{ bimodules in } \bigcup_n N L^2(M_n)_N\}$. In particular for x fixed, $\phi((x^*x)^k) = \tilde{\tau}((\tilde{\Phi}(x)^* \tilde{\Phi}(x))^k)$, for all $k \in \{0\} \cup \mathbb{N}$. By the Riesz representation theorem ϕ and $\tilde{\tau}$ induce compactly supported regular Borel measures $d\phi$ and $d\tilde{\tau}$ on \mathbb{R} with support on $\sigma(x^*x)$ and $\sigma_{\mathcal{S}}(\tilde{\Phi}(x)^* \tilde{\Phi}(x))$ respectively since they are both faithful. Since

$$\int_{\mathbb{R}} \lambda^k d\phi(\lambda) = \phi((x^*x)^k) = \tilde{\tau}((\tilde{\Phi}(x)^* \tilde{\Phi}(x))^k) = \int_{\mathbb{R}} \lambda^k d\tilde{\tau}(\lambda)$$

for all $k \in \{0\} \cup \mathbb{N}$, these measures define the same continuous linear functional on $C_0(\mathbb{R})$. Then by the Riesz representation theorem

$$\sigma(x^*x) = \text{supp}(d\phi) = \text{supp}(d\tilde{\tau}) = \sigma_{\mathcal{S}}(\tilde{\Phi}(x)^* \tilde{\Phi}(x)).$$

Therefore $\tilde{\Phi}$ is norm preserving and we may extend it by continuity to a norm preserving $*$ -homomorphism. \square

Corollary 5.4.7. *The subfactor $N \subset M$ is amenable iff $\sigma(\Gamma\Gamma^t) = \|\Gamma^{A \subset B}\|^2 \sigma(\theta_U)$ where Γ is the principal*

graph of $N \subset M$.

Proof. If $N \subset M$ is amenable then \mathcal{I}_τ is trivial, and so $\tilde{\Phi} = \Phi$ from the previous theorem. We also have

$$e\xi = \Phi(id)\xi = \frac{1}{\|\Gamma^{A \subset B}\|} \sum_{\eta \in \mathcal{L}_{wy}} \left[\begin{array}{c} \text{\$} \\ \nu \quad \lambda_\eta \quad \text{\$} \\ \text{\$} \\ \theta \\ \text{\$} \\ \lambda_\eta^* \quad \nu \quad \text{\$} \\ \text{\$} \end{array} \right] \xi \quad \text{for } \xi \in P_{wyg(bg)^{n_y}}^C$$

which is the orthogonal projection onto the Hilbert space $H_U = \overline{\nu\psi_U \left[1_{wy} \otimes \bigcup_n P_{w(yr)^{n_y}}^C \right] \langle \cdot | \cdot \rangle_{tr}}$. Since $\Phi(\alpha\bar{\alpha}) = \|\Gamma^{A \subset B}\|^2 \Theta_U$ where $\alpha = {}_N L^2(M)_M$, we have a norm preserving representation of $C^*(\alpha\bar{\alpha})$ on H_U via $\alpha\bar{\alpha} \mapsto \|\Gamma^{A \subset B}\|^2 \Theta_U$. Since Θ_U acting on H_U is unitarily equivalent to θ_U acting on H_{yr} , we have $\sigma(\alpha\bar{\alpha}) = \|\Gamma^{A \subset B}\|^2 \sigma(\theta_U)$.

If $N \subset M$ is not amenable then $\sigma(\Gamma\Gamma^t) \neq \|\Gamma^{A \subset B}\|^2 \sigma(\theta_U)$ since one belongs to the spectrum of θ_U . \square

The previous corollary gives a criterion for when symmetric commuting square subfactors are infinite depth. If $\|\Gamma^{A \subset B}\|^2 \theta_U(\xi) = \lambda\xi$ and λ is not an algebraic integer, then $N \subset M$ must be infinite depth. We now considers examples of infinite depth subfactors from symmetric commuting squares. First, infinite depth subfactors are a generic feature of continuous families of biunitaries. The proof of the following is identical to the proof for continuous families of complex Hadamard matrices.

Proposition 5.4.8. *Let $U: \mathbb{R} \rightarrow P_{ygb}^{\Gamma,c}$ be a continuous family of biunitaries for a four partite graph, Γ , coming from inclusion graphs of a connected symmetric commuting square. Then one of the following is true:*

1. *The corresponding principal graphs of the horizontal subfactors are equal for all $t \in \mathbb{R}$.*
2. *There are uncountably many $t \in \mathbb{R}$ such that the corresponding subfactors are infinite depth.*

5.5 Summary and Remarks

We have extended Jones's definition of the angle operator for spin models to symmetric commuting squares with connected inclusions. For subfactors from symmetric commuting squares let $C^*(N \subset M)$ be the C^* algebra generated by the fusion algebra, $\mathcal{F}(N \subset M)$, in the GNS representation associated with $\phi(\alpha) = \dim(\text{Hom}(\alpha, id))$. Then we have the following theorem.

Theorem 5.5.1. *If $N \subset M$ is amenable with principal graph Γ , then there exists a unital norm preserving *-homomorphism*

$$\Phi: C^*(N \subset M) \rightarrow eC^*(M, e_N, JMJ)e$$

extending Φ defined in section 5.3, where $e = \Phi(id)$. Furthermore, for $\alpha = {}_N L^2(M)_M$ $\Phi(\alpha\bar{\alpha}) = [M : N]\Theta_U$ which, represented on $eL^2(M)$, is unitarily equivalent to $[M : N]\theta_U$ on $H_{yr} = \overline{\bigcup_n P_{(yr)^n}^{\mathcal{C}} \langle \cdot \rangle_{yr}}$. Therefore $\sigma(\Gamma\Gamma^t) = [M : N]\sigma(\theta_U)$.

This theorem gives the following criterion which implies symmetric commuting square subfactors are infinite depth.

Proposition 5.5.2. *Let $N \subset M$ be a subfactor from a commuting square with θ_u as its corresponding angle operator. If there exists a non-algebraic integer in $[M : N]\sigma(\theta_U)$, then $N \subset M$ is infinite depth.*

Using this criterion we found families of infinite depth spin model subfactors. We list these examples below.

1. Spin model subfactors from Petrescu's continuous family of 7×7 complex Hadamard matrices (see [Pet97]).
2. Spin model subfactors from type *II* Paley Hadamard matrices (see [Pal33]).

We also showed that infinite depth subfactors are a generic feature of continuous families of biunitaries.

Many more examples of infinite depth subfactors might be shown with this criterion. Type *I* Paley Hadamard matrices, also built from quadratic characters, were considered. Type *I* Paley Hadamard matrices

do yield finite depth subfactors as the 4×4 and 8×8 type *I* Paley Hadamards are equivalent to $\begin{bmatrix} 1 & 1 \\ 1 & -1 \end{bmatrix}^{\otimes 2}$

and $\begin{bmatrix} 1 & 1 \\ 1 & -1 \end{bmatrix}^{\otimes 3}$ respectively. Since the 12×12 type *I* Paley Hadamard is equivalent to the 12×12 type *II* Paley, the type *I* Paley Hadamard matrices yield infinite depth subfactors as well. Numerical computations

suggest that the 20×20 and 28×28 type *I* Paley Hadamard matrices also yield infinite depth subfactors.

Finally, the inability to identify non-algebraic integers in numerical computations was a common obstruction to finding examples. Techniques to guess algebraic expressions for numerical data may lead to many more infinite depth subfactors being identified.

In [Jon21], Jones asked if any complex Hadamard matrices lead to A_∞ principal graph. We showed that Paley type *II* Hadamard matrices are at least two super-transitive, and numerical computations suggest that

Petrescu's 7×7 family is at least three super-transitive. Petrescu's 7×7 family and type *II* Paley Hadamard matrices appear to be candidates for A_∞ principal graphs, however, Jones's question remains open. There are currently a handful of examples of hyperfinite subfactors with A_∞ principal graph. One is due to Ocneanu at the index $\|E_{10}\|^2$ (see [Sch90]), another is due to Bisch at the index 4.5 (see [Bis94]), and a third is given by biunitaries on the graph of the 3311 subfactors (see [IJMS12]). All of these examples rely on the classification of subfactors with a small index (see [Haa94] and [JMS14]). There are currently no techniques to show large index hyperfinite subfactors can have A_∞ principal graphs. These examples warrant further study and a determination of their principal graphs either way would yield interesting examples.

References

- [AMP] N. Afzaly, S. Morrison, and D. Penneys. The classification of subfactors with index at most $5\frac{1}{4}$. *To appear Mem. Amer. Math. Soc. [arXiv:1509.00038]*.
- [BDG09] D. Bisch, P. Das, and S. K. Ghosh. The planar algebra of group-type subfactors. *Journal of Function Analysis*, 257(1):20–46, 2009.
- [BH96] D. Bisch and U. Haagerup. Composition of subfactors: new examples of infinite depth subfactors. *Annales scientifiques de l'Ecole Normale Supérieure*, 29(4):329–383, 1996.
- [BHP12] A. Brothier, M. Hartglass, and D. Penneys. Rigid C^* -tensor categories of bimodules over interpolated free group factors. *J. Math. Phys.*, 53(12), 2012.
- [Bis94] D. Bisch. An example of an irreducible subfactor of the hyperfinite II_1 factor with rational, noninteger index. *J. reine angew. Math.*, 455(8):21–34, 1994.
- [Bis97] D. Bisch. Bimodules, higher relative commutants and the fusion algebra associated to a subfactor. *Fields Institute Communications*, 13:13–61, 1997.
- [Bur10] R. Burstein. Commuting square subfactors and central sequences. *International Journal of Mathematics*, 21(1):117–131, 2010.
- [Bur15] R. Burstein. Group-type subfactors and Hadamard matrices. *Transactions of the American Mathematical Society*, 367(10):6783–6807, 2015.
- [Chr79] E. Christensen. Subalgebras of a finite algebra. *Mathematische Annalen*, 243:17–29, 1979.
- [GHJ89] F. Goodman, P. Harpe, and V. F. R. Jones. *Coxeter graphs and towers of algebras*. Springer Verlag New York Inc., New York, 1989.
- [GJS10] A. Guionnet, V. F. R. Jones, and D. Shlyakhtenko. Random matrices, free probability, planar algebras and subfactors. In *Proceedings of the International Congress of Mathematicians*, pages 1603–1623, 2010.
- [Haa94] U. Haagerup. Principal graphs of subfactors in the index range $4 < [M : N] < 3 + \sqrt{2}$. In *Proceedings of the Taniguchi Symposium on Operator Algebras, World Sci. Publ.*, pages 1–38, 1994.

- [IJMS12] M. Izumi, V. F. R. Jones, S. Morrison, and N. Snyder. Subfactors of index less than 5, part 3: quadruple points. *Communications in Mathematical Physics*, 316(2):531–554, 2012.
- [JMS14] V. F. R. Jones, S. Morrison, and N. Snyder. The classification of subfactors of index at most 5. *Bulletin of the American Mathematical Society*, 51(2):277–327, 2014.
- [Jon83] V. F. R. Jones. Index for subfactors. *Invent Math*, 72:1–25, 1983.
- [Jon19] V. F. R. Jones. Planar algebra notes. <https://cdn.vanderbilt.edu/vu-my/wp-content/uploads/sites/3392/2020/10/15150508/pl21.2019.pdf>, 2019.
- [Jon21] V. F. R. Jones. Planar algebras. *New Zealand Journal of Mathematics*, 52:1–107, 2021.
- [JS97] V. F. R. Jones and V. S. Sunder. *Introduction to subfactors*. Cambridge University Press, Cambridge, 1997.
- [JX04] V. F. R. Jones and F. Xu. Intersections of finite families of finite index subfactors. *International Journal of Mathematics*, 15(7):717–733, 2004.
- [KS99] V. Kodiyalam and V. S. Sunder. Spectra of principal graphs. *International Journal of Mathematics*, 12(2):203–210, 1999.
- [MP14] S. Morrison and E. Peters. The little desert? some subfactors with index in the interval $(5, 3 + \sqrt{5})$. *International Journal of Mathematics*, 25(8):1450080, 2014.
- [Pal33] R. E. A. C. Paley. On orthogonal matrices. *Journal of Mathematics and Physics*, 12:311–320, 1933.
- [Pet97] M. Petrescu. *Existence of continuous families of complex Hadamard matrices of certain prime dimensions*. PhD thesis, University of California at Los Angeles, 1997.
- [Phi74] J. Phillips. Perturbations of type *I* von neumann algebras. *Pacific Journal of Mathematics*, 52(2):505–511, 1974.
- [Pop94a] S. Popa. Symmetric enveloping algebras, amenability and AFD properties for subfactors. *Mathematical Research Letters*, 1:409–425, 1994.
- [Pop94b] Sorin Popa. Classification of amenable subfactors of type *II*. *Acta Mathematica*, 172(2):163–255, 1994.

- [Pop95] S. Popa. An axiomatization of the lattice of higher relative commutants of a subfactor. *Invent Math*, 120:427–445, 1995.
- [Pop99] S. Popa. Some properties of the symmetric enveloping algebra of a subfactor, with applications to amenability and property T. *Documenta Mathematica*, 4:665–744, 1999.
- [PP86] M. Pimsner and S. Popa. Entropy and index for subfactors. *Annales scientifiques de l'Ecole Normale Supérieure*, 19(4):57–106, 1986.
- [Sat97] N. Sato. Two subfactors arising from a non-degenerate commuting square. *Pacific Journal of Mathematics*, 180(2):369–376, 1997.
- [Sch90] J. K. Schou. *Commuting squares and index for subfactors*. PhD thesis, Odense University, 1990.
- [SW94] T. Sano and Y. Watatani. Angles between two subfactors. *Journal of Operator Theory*, 32:209–241, 1994.
- [Wen88] H. Wenzl. Hecke algebras of type A_n and subfactors. *Inventiones mathematicae*, 92(2):349–384, 1988.

Appendix A

Code for Petrescu's complex Hadamards

```
1 t=sym('t'); %This symbol stands for lambda.
2 w=sym(exp(1i*pi/3)); %w is the 6th primitive root of unity.
3 u = [t*w t*w^4 w^5 w^3 w^3 w^1 1;
4       t*w^4 t*w w^3 w^5 w^3 w^1 1;
5       w^5 w^3 conj(t)*w conj(t)*w^4 w^1 w^3 1;
6       w^3 w^5 conj(t)*w^4 conj(t)*w w^1 w^3 1;
7       w^3 w^3 w w w^4 w^5 1;
8       w w w^3 w^3 w^5 w^4 1;
9       1 1 1 1 1 1 1]./sqrt(7);
10 Eigenvalue=sym('1/49');
11 EigenvectorArray=[0 0 1 -1 (1/sqrt(3))*imag(t*conj(w)) (-1/sqrt(3))*imag
12 (t) (1/sqrt(3))*imag(t*w);
13 0 0 -1 1 (1/sqrt(3))*imag(t*conj(w)) (-1/sqrt(3))*imag(t) (1/sqrt(3)
14 )*imag(t*w);
15 1 -1 0 0 (1/sqrt(3))*imag(t) (-1/sqrt(3))*imag(t*w) (-1/sqrt(3))*
16 imag(t*conj(w));
17 -1 1 0 0 (1/sqrt(3))*imag(t) (-1/sqrt(3))*imag(t*w) (-1/sqrt(3))*
18 imag(t*conj(w));
19 (1/sqrt(3))*imag(t*conj(w)) (1/sqrt(3))*imag(t*conj(w)) (1/sqrt(3))*
20 imag(t) (1/sqrt(3))*imag(t) 0 2*real(t) -2*real(t*conj(w));
21 (-1/sqrt(3))*imag(t) (-1/sqrt(3))*imag(t) (-1/sqrt(3))*imag(t*w)
22 (-1/sqrt(3))*imag(t*w) 2*real(t) 0 -2*real(t*w);
23 (1/sqrt(3))*imag(t*w) (1/sqrt(3))*imag(t*w) (-1/sqrt(3))*imag(t*conj
24 (w)) (-1/sqrt(3))*imag(t*conj(w)) -2*real(t*conj(w)) -2*real(t*w
25 ) 0];
26 Eigenvector=sym('e',[49 1]);
```

```

19 for a1=1:7 %Since we are representing everything on  $P_{2,+}^{\text{Spin}}$  we
    use 2-digit base 7 numbers for rows and columns.
20 for a2=1:7
21     Eigenvector(a1+7*(a2-1),1)=EigenvectorArray(a1,a2);
22 end
23 end %The definition of the profile matrix can be found in [Jon99].
24 AngleOp=sym('A',[7^2 7^2]); %The angle operator as represented
    on  $P_{2,+}^{\text{Spin}}$ .
25 for a1=1:7
26     for a2=1:7
27         for b1=1:7
28             for b2=1:7
29                 r=sym(0); %r is a running total for each entry of the
                    profile matrix (Defined in [Jon99]).
30                 for m=1:7
31                     r=r+u(m,b1)*conj(u(m,b2))*conj(u(m,a1))*u(m,a2);
32                 end
33                 AngleOp(a1+7*(a2-1),b1+7*(b2-1))=7*r*conj(r);
34             end
35         end
36     end
37 end
38 Test=7*AngleOp*Eigenvector-Eigenvalue.*Eigenvector; %If Test is zero
    then 1/49 is an eigenvalue of 7*AngleOp.
39 Substitute1=subs(Test,real(t),(t+conj(t))/2);
40 Substitute2=subs(Substitute1,imag(t),(t-conj(t))/(2i));
41 TestExpanded=expand(Substitute2);
42 Substitute3=subs(TestExpanded,t*real(t),(1/2)*(t^2+1));
43 Substitute4=subs(Substitute3,t*conj(t),1); %Here we make several
    substitutions utilizing  $|t|=1$  and expand terms.

```

```
44 if any(Substitute4~='0')
45 EigenvectorTest=false;
46 else
47 EigenvectorTest=true;
48 end
49 clear a1 a2 b1 b2 m r
```