

NAVIGATION EXPERIENCE IN VIDEO GAME ENVIRONMENTS:  
EFFECTS ON SPATIAL ABILITY AND MAP USE SKILLS

By

Brian N. Verdine

Dissertation

Submitted to the Faculty of the  
Graduate School of Vanderbilt University  
in partial fulfillment of the requirements

for the degree of

DOCTOR OF PHILOSOPHY

in

Psychology

May, 2011

Nashville, Tennessee

Approved:

Professor Georgene L. Troseth

Professor John J. Rieser

Professor Timothy P. McNamara

Professor Daniel T. Levin

Professor Robert M. Hodapp

To Mo, for all the backyard  
pumpkin carving fires we didn't have.

## ACKNOWLEDGEMENTS

I am thankful for the financial support of this project by grant # T32HD07226 from the National Institute of Child Health and Human Development to Vanderbilt University, grant # P30 HD15052 to the Vanderbilt Kennedy Center for Research on Human Development, and grant # 1 UL1 RR024975 from the National Institutes of Health's National Center for Research Resources to the Vanderbilt Institute for Clinical and Translational Research.

I am also thankful for the long list of people that made this project possible. Each member of my Dissertation Committee has generously provided me with personal and professional guidance I will continue to use throughout my life. My advisor, Georgene Troseth, was instrumental for all aspects of this project. Gabrielle Strouse and Kate O'Doherty also provided helpful ideas and support throughout this process. The faculty and staff of the Early Development Lab was indispensable; specifically Lauren Deisenroth, Michael Bailey, Allison Pfeiffer, Bailie Hardin, Ekomobong Essien, and Sima Baalbaki who all helped manage the mountain of data this study produced.

Jon Tapp, the Vanderbilt Kennedy Center's Director of Information Technology, provided the expert programming for creating the computer-based measures, and Jacob Thornton, Vanderbilt University's GIS Coordinator, committed a significant amount of time to teaching me to use Geographic Information Systems as a means of displaying and analyzing data from this study.

A number of individuals outside of Vanderbilt University also provided generous assistance with this project. Lynn Liben (The Pennsylvania State University) and Nora Newcombe (Temple University) provided helpful input in the latter stages of the study design, and Patrick Garrigan (Saint Joseph's University) and Alicia Chang (University of California Los Angeles) helped me acquire stimuli for parts of the study.

It is also impossible to overvalue the contribution of friends and family to the completion of this project. They may not have helped design the studies, collect the data, or edit this dissertation, but they certainly helped make it so that I could.

# TABLE OF CONTENTS

	Page
DEDICATION .....	ii
ACKNOWLEDGEMENTS .....	iii
LIST OF FIGURES .....	vii
LIST OF TABLES .....	viii
Chapter	
I. LITERATURE REVIEW .....	1
Overview .....	1
Wayfinding and Navigation .....	2
Immersive and Desktop Virtual Environments .....	3
Research Plan .....	9
Preliminary Research: Video Game Task Analysis .....	11
STUDY 1: ONLINE QUESTIONNAIRE	
II. METHOD .....	16
Overview .....	16
Participants .....	16
Procedures .....	19
Measures .....	19
III. RESULTS .....	20
Factor Analysis .....	20
Game Player Characteristics .....	26
Genre Analyses .....	26
Sex Differences .....	28
Early Spatial/Navigation Experience .....	28
IV. DISCUSSION .....	30

## STUDY 2: VIDEO GAME TRAINING EXPERIMENT

V. METHOD .....	34
Overview.....	34
Participants.....	34
Measures and Materials .....	37
Visual-Spatial Measures.....	37
Navigation Measures .....	39
Language Ability.....	42
Procedures.....	42
Computer-Based and Pencil-and-Paper Testing.....	42
Real-World Navigation Testing.....	44
Group Assignment and Training.....	48
Post-Test Procedures.....	55
Scoring and Calculations .....	56
VI. RESULTS .....	59
Sample Comparisons .....	59
Measure Development .....	60
Navigation and Map Use Questionnaire Reliability.....	60
Navigation and Map Use Questionnaire Validity .....	60
Photo-Map Task Reliability .....	62
Photo-Map Task Validity .....	63
Real-World Map and Spatial Memory Tests.....	65
Heading and Distance Estimate Adjustments .....	72
Video Game Learning.....	73
Journal and Exit Survey Results .....	76
Gender Differences .....	79
Pre-Test (T1) Differences.....	79
Journal and Exit Survey Sex Differences .....	80
VII. DISCUSSION .....	83
VIII. GENERAL DISCUSSION.....	86
1. Transfer of Navigation Skills from Video Games to the Real World .....	87
2. Video Game Playing, Spatial Ability, and Game Design.....	90
3. Sex Differences in Navigation, Spatial Ability, and Video Game Play .....	93
4. Navigation Measure Development .....	94
Conclusion .....	95
Appendix	
A. MAJOR VIDEO GAME GENRES .....	96

B. STUDY 1 QUESTION TYPES.....	97
C. MEASURES USED IN STUDY 2.....	98
D. CONFLICT OF INTEREST STATEMENT .....	101
REFERENCES .....	102

## LIST OF FIGURES

Figure	Page
1. Distribution of Participants from Study 1 (Only participants from U.S. portrayed) .....	18
2. Mental Rotation Task Example .....	38
3. Real-World Map Test Park Map.....	41
4. Photo-Map Task Instruction Slides.....	43
5. Real-World Map Task (MT) and Spatial Memory (SM) Paths and Landmarks on Satellite Image of Centennial Park .....	46
6. Screen Shots from <i>Elder Scrolls IV: Oblivion</i> .....	50
7. Elder Scrolls IV: Oblivion In-Game Map.....	52
8. Diagram Illustrating the Use of Portals and Character Velocity to Traverse a Gap Too Wide to Be Jumped in the Game <i>Portal</i> . .....	53
9. Portal Screenshot .....	54
10. Compass Diagram and Heading Estimate Scoring Example .....	58
11. Real-World Map Test—Placement Estimates from All 3 Pre-Test Trials .....	67
12. Real-World Map Test—Heading/Distance Estimate Plots from 2 Pre-Test Trials .....	68
13. Real-World Spatial Memory Test—Heading/Distance Estimates from the Light Pole to the Obelisk .....	70

## LIST OF TABLES

Table	Page
1. Video Game Players' Ratings of Skills Needed by Video Game Type .....	12
2. Questionnaire Items Removed During Factor Analysis .....	22
3. Factor Analysis Loadings, Factor Reliability, and Final Scales .....	24
4. Study 1 Factor Correlations .....	25
5. Partial Correlations Between VG Genre Preferences and Questionnaire Factors with Gender as a Covariate .....	27
6. Partial Correlations Between Estimated VG Genre Exposure and Questionnaire Factors with Gender as a Covariate .....	28
7. Study 2 Questionnaire Correlations .....	61
8. Photo-Map Task Correlations .....	64
9. Study 2 - Time 1: Raw Data from Real-World Navigation Testing .....	66
10. Real-World Navigation Test Correlations .....	71
11. Training Group Pre- and Posttest Means and Standard Deviations .....	74
12. Training Group Post-Hoc Comparisons in Study 2 .....	75
13. Gender Difference Post-Hoc Comparisons in Study 2 .....	76
14. Game Play Descriptive Statistics from Participant Logs .....	77
15. Gender Differences at Time 1 .....	80
16. Journal and Exit Survey Gender Differences .....	81



## CHAPTER I

### LITERATURE REVIEW

#### Overview

Since the early days of Atari, video games have grown in popularity to become a multi-billion dollar industry. Children who might in earlier generations have gone for bike rides or explored a local patch of woods may now be spending increasing amounts of their limited leisure time in front of the TV or computer screen with a video game controller in hand, navigating a virtual environment (Subrahmanyam, Kraut, Greenfield, & Gross, 2000). The popularity of video games is of concern to school principals, public health officials, and parents who worry about the impact that violent video games and/or the sedentary nature of the activity could have on the development of children. A number of studies indicate that these concerns are well founded (Carnagey & Anderson, 2005; Vandewater, Shim, & Caplovitz, 2004).

Given that people of all ages are playing video games, and that this pastime is unlikely to go away, a relevant question is whether anything valuable can be learned from such games. With their highly engaging format and their ability to incorporate difficult problem-solving situations, video games might be effective in providing relevant learning experience to children and adults. A number of studies already indicate that video games have positive effects on certain basic aspects of cognitive functioning such as spatial ability (Subrahmanyam & Greenfield, 1994), increased capacity of visual attention (Green & Bavelier, 2003; Feng, Spence, & Pratt, 2007), and faster visual stimulus response (Castel, Pratt, & Drummond, 2005).

Advancing video game technology allows today's game makers to render ever more realistic and detailed environments. Although they usually have portrayed fictional environments, video game environments can look every bit as real as most virtual environments (VE's) fashioned for desktop virtual reality systems. With the advent of online, massively multiplayer games (e.g., *Everquest*, *World of Warcraft*, etc.), the environments that gamers can navigate are becoming practically limitless. Larger, more realistic, and more detailed environments demand more accurate virtual wayfinding in unfamiliar spaces, and require the use of distinctive cues and landmarks for guiding that navigation. Similarly, with the advent of a large number of "first-person" games (e.g., *Portal*, *Medal of Honor*, *Halo*, etc.), gamers can play

using the “on-the-ground” viewpoint of the character, receiving visual input at least partially mimicking that of a real person navigating a real environment.

### Wayfinding and Navigation

*Wayfinding* and *navigation*, two terms used throughout this paper, are often used interchangeably and have been used in different ways throughout the literature (e.g., Peponis, Zimring, & Choi, 1990; Loomis, Klatzky, Golledge, & Philbeck, 1999). In this paper, *navigation* will typically be used to refer to planned movements from one location to another, disregarding the complexity of the movements or the underlying cognitive processes. The steps necessary for all types of navigation include understanding one's current location (including current heading), planning a path from that location to a destination, maintaining/adjusting one's route during travel, and knowing when one has arrived (Downs & Stea, 1973). Similarly, *wayfinding* involves movement from one location to another, but implies navigating to a specific target destination by integrating available sensory information with stored information: concrete and/or mental representations of the environment. This definition of wayfinding includes *memory-based* wayfinding using procedural (route) and survey knowledge acquired through past experience in a particular environment (i.e., from primary learning—Presson & Hazelrigg, 1984). This definition of wayfinding also includes navigation, often toward *novel* destinations, planned with the assistance of navigational aids—symbolic representations of space such as a map or written directions, and tools such as compasses and GPS systems; that is, anything used to fill gaps in procedural and survey knowledge (i.e., secondary learning).

This last activity will be referred to throughout this dissertation as *map-based* wayfinding because of my focus on the acquisition of map use skills (however, there are other navigational aids and skills like dead-reckoning that may be helpful for wayfinding). Making a distinction between *memory-based* and *map-based* skills highlights the contrast between skills that are primarily used in familiar spaces (memory-based) and those typically used when trying to navigate in unfamiliar environments (map-based). The experiences necessary to improve these two skill sets likely are quite different even though they can be (and often are) used in concert.

Most prior research on navigation in virtual environments (VE's) has focused on memory-based transfer of spatial layout information across similar environments (i.e., using readily available, *environment specific* information obtained in a VE to complete a task in an

analogous real environment—what would be considered “near transfer” in Barnett and Ceci’s 2002 taxonomy of transfer). In contrast, I am investigating *far transfer* of map-based wayfinding skills: applying expertise gained from using navigational aids in VE’s for wayfinding in *novel* real-world environments. As discussed below, the latter would appear to have more utility from an educational standpoint. Evidence that navigating in real environments leads to increases in basic level spatial skills (Munroe & Monroe, 1971; Nerlove, Munroe, & Munroe, 1971) raises the possibility that experience navigating/wayfinding in video game environments might also improve this set of cognitive abilities and their use in novel situations (i.e., far transfer of skills). In a recent study, Feng et al. (2007) found that playing a first-person shooter game modified participants’ scores on spatial attention and mental rotation tasks, an apparent example of the far transfer of basic spatial skills from a video game to a non-game testing environment.

Navigational aids similar to those used to find one’s way in the real world are provided in some video games. Games with large scale environments often make use of maps—either digital maps integrated into the game that update with player movements, or paper maps included with the game or appearing in strategy guides. One noteworthy paper version is a 192-page atlas published by Brady Games (2005) that details the virtual terrain for the game *World of Warcraft*. Other games make use of radar-like screens that give the player constantly updated headings for navigating to desired waypoints (similar to the output of GPS—Global Positioning Systems). The combination of these navigation tools and the ever-more-realistic game environments experienced by players may foster their learning to navigate and wayfind in real-world environments. To date, relatively few studies have investigated these potentially beneficial aspects of video game playing.

### Immersive and Desktop Virtual Environments

Immersive VE’s are similar to video games in their ability to realistically depict space. Recently a lot of excitement has been generated around developing immersive systems and understanding how people react to them due to the plethora of current applications (e.g., flying and driving simulators, product design, astronaut training, psychiatric treatment for phobias, and even controlling ultra-sensitive probe microscopes—Brooks, 1999) and potential future uses (e.g., virtual tours of famous landmarks or locations, military and police training for missions in specific unfamiliar environments, simulated training of expensive, rare, or dangerous procedures,

etc.). Currently, however, the technology is not without problems: VE's are expensive, new environments are difficult to render, the equipment can be fickle, and users often experience "simulator sickness". Additionally, the size of the VE is limited by the size of the real environment the user is actually navigating (i.e., the area in which the head mounted display can be detected by the main computer). Virtual reality systems probably will be the gold standard for simulated navigation in the future because of their unparalleled ability to reduce outside distractions and increase *presence* (i.e., the subjective experience of being in one place when one is physically in another—Witmer, Bailey, & Knerr, 1996). However, immersive virtual reality currently is available only to organizations that can afford the expensive technology and trained technicians to run it.

Despite these problems, immersive environments do have one potentially important advantage over video games: navigational control through body movements providing proprioceptive and vestibular input—referred to here as *body-based cues*. There is good evidence from real-world navigation studies that self-directed movement allows for better estimations of distance and direction than can be made while riding in some type of vehicle or device (Loomis, Da Silva, Fujita, & Fukusima, 1992). For children, self-directed movement leads to a better representation of the physical environment (Shantz & Watson, 1971). *Rotational changes* (i.e., changes in heading) as opposed to *translational movements* (from one location to another) are particularly difficult to track (Rieser, 1989). This evidence from real-world studies indicates that effortful control and body-based cues may be important for the accurate representation of space in VE's.

Participant responses to VE's appear to be fairly congruent with earlier work in real-world spaces, supporting the conclusion that there is a real advantage to having proprioceptive and vestibular cues present for navigating in virtual reality simulations. For example, in a study by Ruddle and Lessels (2006), participants were asked to find 8 marked boxes out of a group of 16 that were arrayed among 33 possible locations throughout a virtual room. Search performance in a group using full body movements was significantly more efficient than in either a *no movement* condition (in which a mouse and keyboard were used to dictate all movements) or a *rotation-only* condition (a button was used to control translational movement, and body turns controlled rotation). In this virtual environment, rotation-only, which still provided some body-based information, did not lead to better navigation compared to the no-movement condition.

This result is somewhat surprising considering real world research showing that rotational changes are particularly difficult to track (e.g., Rieser, 1989); one would expect a benefit from the inclusion of body-based cues. However, in a much simpler study by Bakker, Werkhoven, and Passenier (1999), a significant advantage of body-based rotational movements (in comparison to no movement) was found for the ability to judge rotation angles (a skill necessary for navigational heading changes). It seems likely that task differences are responsible for the different effects of rotation in these studies. Whereas rotation alone allowed for accurate judgment of rotational angles, both rotation and translational movements seemed to be necessary for accurate representation of the location and identities of objects in a room. In any case, it seems quite clear that body-based cues play some role in navigation and specifically in the realm of memory-based processes.

However, a number of studies have established navigation using “desktop” VE’s (that is, non-immersive systems displayed on computer or TV screens)—without body-based feedback—as a legitimate proxy for real-world navigation. These studies have determined that place learning from on-screen representations does transfer to the identical real-world space. Wilson, Foreman, and Tlauka (1997) found that configural knowledge (the layout) of particular buildings could be learned through experience exploring a VE presented on a standard computer monitor. Configural knowledge, assessed using participants’ free-hand plan map drawings of a building and through their pointing to relevant landmarks from a testing room, was equal for groups who received navigation experience in the VE or in the real environment, and both groups performed better than a control group did.

Péruch, Belingard, and Thinus-Blanc (2000) found that, compared to participants trained in a specific real-world environment (a college campus), participants trained in a desktop VE to locate campus landmarks had similar estimates of the relative locations of and distances to landmarks. They also found that the more realistic the virtual model of the campus, the more transfer of knowledge there was to the real campus. Therefore, the literature indicates that near transfer does occur; that is, specific information obtained in VE’s does transfer (with at least reasonable fidelity) to tests performed in the *same* real world space.

These findings related to desktop environments are promising when considering whether video game environments could be a venue in which to acquire map- and memory-based wayfinding skills. However, these results contrast directly with the previously discussed

evidence that body-based cues are vitally important in the creation and maintenance of accurate spatial representations of VE's. One potential explanation for differences in the usefulness of non-physical navigation across these studies is task complexity. In experiments where the task demands are already high, experimental groups given unusual or unfamiliar control interfaces to use in virtual navigation (such as a mouse and keyboard/keypad in Ruddle and Lessels' (2006) *rotation only* and *no movement* conditions) may face additional cognitive demands simply to move through the virtual space.

Accurate memory-based navigation relies heavily on the construction and recall of high fidelity representations of space. Therefore, the ability to construct these mental representations would appear to be of fundamental importance to learning new memory-based navigation skills. If body-based cues are of paramount importance to the construction of an accurate spatial representation of an environment, individuals navigating desktop VE's (including video game environments like those used in this study) should be unable to construct and maintain high-fidelity mental representations of those spaces. The resulting conclusion would be that regardless of the amount (or type) of experience given in a desktop VE, or how realistic or complex the depiction of the environment is, no meaningful level of transfer for memory-based navigation skills should be expected in the absence of body-based cues.

However, navigating in the real world, navigating by coordinating body movements with virtual reality viewed via a head mounted display, and navigating a desktop VE by the use of a control device are inherently different tasks with different demands—tasks with which most people do not have equal levels of expertise. By increasing the number of learning trials, Waller, Hunt, and Knapp (1998) were able to eliminate a gap in survey knowledge that they initially found between experiences using a head-mounted system with a joystick to control movement and experiences in the real world. Waller et al. also used an extended training period at the beginning of the experiment to thoroughly familiarize participants with the control interfaces for their virtual systems (the desktop environment used a monitor display and joystick for movement and their immersive system used a head-mounted display with a joystick). Participants were able to reach criterion (complete a training maze in less than 4 minutes) after 30-75 minutes of training. Possibly as a consequence of participants' mastery of the control interface, this navigation study is one of a few in which there was little difference between path knowledge obtained in the two different types of VE systems. Surprisingly, fidelity of survey knowledge

(i.e., knowledge of the layout of the environment) was actually superior in the group that used the desktop systems.

As the above research would suggest, practicing and automatizing the control of movements reduces cognitive load and probably helps with the construction of mental representations. It seems likely that expert players of first-person video games not only have automatized their control of joysticks or similar devices as navigation tools, but may also link their experience of using game control devices and visual information in ways that compensate for a lack of body-based information. (Something similar may happen as a person accustomed to an electric wheelchair connects his/her control of the wheelchair to the visual landscape.) To my knowledge, no research examines the extent to which expert players may compensate for a lack of body-based cues, nor am I aware of research documenting real-world distance estimation or the fidelity of mental representations of space with expert/non-expert users of transportation systems that eliminate body-based cues for translational movements.

There is evidence that only 8 to 10 minutes of visual experience that is incongruent with body movements (i.e., a visual field that is moving faster or slower than a person is actually walking) is sufficient to modify the calibration between body-based cues and perception of the actual distance travelled (Rieser, Pick, Ashmead, & Garing, 1995). I take that as an indication that our systems likely are flexible enough to adjust to the different/attenuated proprioceptive and vestibular cues available in VE's. Perhaps the issue is one of expertise: expert users of navigational control devices may represent navigated space similar to walkers, and differences in prior studies showing an effect of body-based cues in virtual environments reflect the novelty of the navigation method itself taxing limited cognitive capacities.

The importance of body-based cues in learning from VE's may also depend on what participants are being asked to learn. Certain navigational skills are not likely to improve following experience in desktop VE's, including: 1) those that are highly practiced due to everyday experiences in the real world and 2) those that desktop setups generally are poor at replicating (e.g., walking through an environment and avoiding obstacles, or using proprioceptive and vestibular cues to judge the distance and direction of relative points along a path). In contrast, acquisition of map-based wayfinding skills is less likely to be affected by missing body-based cues for several reasons. First, learning can be supported by the use of *stable external* representations (not *dynamic mental* representations). Also, many of the requisite

skills require little, if any, movement in space (e.g., learning to figure out your position in an environment from a map; learning to use the graphical conventions and scales of maps). Finally, a reasonable portion of the population remains deficient in map skills; therefore, for many people, map skills are not “over-learned” (Liben, Kastens, & Stevenson, 2002).

Although the research reported here does not test for the effects of body-based cues on knowledge gained from VE's, it is partly based on the assumption that people can construct reasonably coherent mental representations of those environments. Further, I expect that these representations will have good enough fidelity to allow general wayfinding skills to be learned in desktop VE's. Currently, there is almost no research on the learning and transfer of skills (as opposed to place-specific knowledge) from VE's to the real world. However, past research has shown that paper maps facilitate the learning of survey knowledge (Thorndyke & Hayes-Roth, 1982); the use of maps contributes to the coherence and fidelity of participants' spatial representations. Therefore, maps would be expected to help support the learning of skills and spatial knowledge from VE's. Finally, I posit that skills learned in navigating video game VE's can be transferred to *novel* real-world situations; this would involve far transfer beyond applying specific knowledge of a VE to the corresponding real environment (Barnett & Ceci, 2002).

Compared to specific location information, general skills may be more useful to learn from a VE given that many applications for VE's do not require (or allow) transfer of specific spatial knowledge from a VE to an analogous real environment. Despite the amount of research dedicated to comparing cognition in analogous real world and virtual environments, most future applications of VE's for the general public would occur because the real environment being simulated is somehow inaccessible. Therefore, no matching between real and simulated environments will be possible. For example, the real referent of a simulated environment might be: 1) impossible to experience because of its scale or distance (e.g., occurring at the cellular or cosmic level) or 2) currently inaccessible (e.g., historical buildings, projected new home designs). Simulations in which inaccessible environments are made available are likely to become the most common virtually rendered environments, whereas applying place learning from a specific VE to the matching real-world space may be less common and may have only limited applications. For this reason, determining if map- and memory-based wayfinding skills acquired in a VE transfer and generalize to different real-world situations is a useful and interesting line of inquiry. Additionally, there is some evidence that navigation in real (Munroe



& Monroe, 1971; Nerlove, Munroe, & Munroe, 1971) and virtual (Feng et al., 2007) environments improves some aspects of spatial ability, a related (and educationally important) cognitive area.

The possibility that navigation in VE's might lead not only to near transfer to real environments (place-learning) but also to far transfer (increasing general navigation skills and spatial ability) gives VE's the potential to fill an educational niche. Wayfinding strategies and skills are only rarely taught explicitly to children. As a result, a surprising number of adults are poor at map-based wayfinding, a fact illustrated in the current results (also see Liben et al., 2002). There are significant individual differences in adults' reports of their competence and confidence in navigating (Hegarty, Montello, Richardson, Ishikawa, and Lovelace, 2006). Nevertheless, map-based wayfinding is a skill that is important for everyday functioning, including personal safety (e.g., avoiding a bad neighborhood while navigating across a city), efficient time use (e.g., finding the quickest routes between destinations), and for a variety of jobs and careers (e.g., taxi driver, surveyor, geologist, pilot, etc.).

### Research Plan

The potential advantages of using video games for wayfinding instruction have received little attention. The current research attempts to further clarify the relation between playing specific game types and increased map- and memory-based wayfinding skills in real-world environments, using individual differences in video game preferences reported in an online questionnaire (Study 1) and comparisons between groups of novice players who were assigned to play different video games (Study 2).

In developing the measures for the online questionnaire and training study, I carried out a task analysis of video game genres and the specific skills used in playing different types of video games. Many prior studies either have focused entirely on one video game or have treated all video games as homogeneous, ignoring major differences present in gaming genres (e.g., in player perspective, 2D vs. 3D space, turn-based vs. real-time, continuous formats, etc.). Results from the few studies attempting to distinguish between genres indicate the vital importance of these distinctions. For example, Feng et al. (2007) found that experience playing a first-person shooter game for 10 hours over 4 weeks modified participants' scores on spatial attention and mental rotation tasks, but playing a 3-D puzzle game that involved steering a ball through a

hovering maze of paths and rails while avoiding obstacles had no effect. In this instance, it was not video game playing in general that had the effect, but instead the playing of games requiring the *use of specific abilities*. Extrapolating from these results, it is plausible that a preference for playing different kinds of video games will be related to differences in the skills that are taught by or are required to play that kind of game. The questionnaire study attempted to address some of these issues related to game-playing preferences.

The research was also aimed at identifying possible ways to reduce commonly reported sex differences in visual-spatial ability (particularly as they relate to skill in using maps) and to determine whether video game playing has a similar effect on males and females. Feng, et al. (2007) found that only 10 hours of training for non-video game players on a first-person action game increased mental rotation scores for both males and females. This training was so effective for the female participants that it actually eliminated a pre-test sex difference in mental rotation scores. This finding indicates that video games hold promise as a potential tool for narrowing the gender gap in spatial ability. However, wayfinding is a higher-level cognitive skill compared to mental rotation and it calls upon an array of underlying abilities. It is not clear that a higher level skill will be as easily trained even when a person is provided with relevant experience.

Finally, a significant problem in studying navigation is the space and time required to test participants' abilities. Across testing locations, similar methods may yield different results simply due to differences in the space. Outdoor spaces (in particular) are also prone to a number of problems in exercising experimental control: daily differences in weather, changes in the area to be navigated due to the seasons, random encounters with other people in the environment, difficulty in keeping conditions constant across the time necessary to complete a study (e.g., construction projects changing the testing environment), etc. The upside to these challenges is that findings that replicate across different studies are likely to be robust. The downside is a lack of quick, easy to administer standardized tests of the construct and difficulty interpreting differences in findings across studies. Real-world tests of navigation were planned early on as a part of this research. Additionally, I took this opportunity to develop two in-lab measures that I expected to be related to my real-world test outcomes.

In summary, the main goals of this research are: 1) determining if *general* skills learned in VE's (e.g., map- and memory-based wayfinding strategies and the use of navigational tools) can be applied to solve real-world wayfinding problems; 2) clarifying the relation between video

game playing and visual-spatial ability by incorporating the use of multiple games (a role-playing game and a first-person puzzle game) and measuring preferences for and experiences with specific types of video games; 3) exploring sex differences in an area with relatively large discrepancies—in video game experience, ability, and interest, as well as visual-spatial and navigational abilities; and 4) developing in-lab measures related to real-world navigation that are relatively quick to administer in a controlled way, easy to score, and possible to administer efficiently to large numbers of participants.

### Preliminary Research: Video Game Task Analysis

As groundwork for the research, I carried out a detailed task analysis of video games, investigating the skills required to play the different genres or types. I analyzed the importance of game play features (e.g., character perspective or game viewpoint, pace of game action, etc.) across different video games, and the effects that exposure to those features might have on players. The task analysis was intended to help guide specific decisions such as the choice of video games to be used in the research, the addition of specific questions about video game experience in the questionnaires, and the generation of hypotheses. What follows is a short description of the method used for this preliminary research and a summary of the more important findings.

First, I created a list of psychologically relevant skills likely to be used in video games. These skills were divided into *game-specific* skills/knowledge (use of the control interface and knowledge of the video game environment) and *transferable* skills/knowledge (those that could be applied across game types or to the real world, including visual processing, reaction time, problem solving or cognitive load, use of symbol systems, navigation, pattern recognition, memory, and theory of mind).

I then compiled an exhaustive list of over 50 major categories and subcategories of video game types, along with examples, from information found on Wikipedia.com (2007). Wikipedia is an open source reference that is kept current. The entry on video game genres reflects the thoughts and opinions of a wide range of people with experience with video games (particularly useful when categorizing those games). As a means of verifying the accuracy of the list, I compared it to information on video game industry websites, which led me to simplify the list by combining a number of the subcategories. In most cases, the combined categories reflected

historical changes in the gaming industry, such as a shift from 2-D to 3-D for certain game types (e.g., “platform” games like Super Mario Bros., where the primary object of the game is to jump from platform to platform while avoiding obstacles). These changes typically had more to do with advances in technology than any meaningful difference in the skills and abilities used to play the older and newer versions of the games. Focusing on the list of psychologically-relevant skills I had compiled and trying to group subgenres as closely as possible based on those skills, I also used my own experience of these genres to guide a number of category rearrangements. For instance, racing simulations were moved from the “simulation” category to the action category because compared to other simulations (e.g., flight simulators), the game play is relatively fast-paced and the control schemes are simpler/more familiar. See [appendix A](#) for the final list.

To determine the extent to which the different skills are used in the various video game categories, I had 10 routine video game players rate types of games based on definitions for each of the skills used in different genres. The video game players rated the extent to which each of the skills was used in each video game type and subtype on a scale of 1 (low) to 10 (high). I calculated a mean rating on each skill for each of the major video game types (see [Table 1](#)). Raters were not made aware that the research I was conducting was focused on navigation.

Table 1. Video Game Players' Ratings of Skills Needed by Video Game Type

	Navigation	Use of Symbolic Systems	Memory	Visual Processing	Pattern Recognition	Problem Solving	Reaction Time	Theory of Mind
Adventure	<b>8.1</b>	<b>8.4</b>	<b>8.6</b>	6.8	6.0	<b>8.2</b>	5.1	5.6
Shooter	<b>7.8</b>	<b>6.7</b>	<b>7.0</b>	<b>9.0</b>	<b>7.0</b>	6.1	<b>8.9</b>	<b>5.9</b>
RPG	<b>7.6</b>	6.4	6.5	6.5	6.2	<b>6.6</b>	5.8	<b>6.9</b>
Strategy	6.9	<b>6.9</b>	5.7	6.4	6.2	6.5	5.9	5.4
Simulation	6.1	6.2	5.2	6.7	5.3	5.9	5.7	4.9
Action	4.9	4.7	5.1	7.2	6.0	4.4	7.6	4.4
Other	3.7	4.6	<b>7.3</b>	5.9	6.6	<b>7.0</b>	5.3	4.2
Sports	3.4	6.2	5.3	<b>8.6</b>	<b>7.5</b>	5.1	<b>9.3</b>	5.6
Music	1.6	3.3	6.7	<b>8.5</b>	<b>7.0</b>	2.7	<b>8.4</b>	<b>5.9</b>

Ratings in bold indicate the genres with the 3 highest scores for each skill. Average ratings are based on a 1-10 scale with high scores indicating that a skill is more heavily used to play games from that genre. Video game genres were ordered by average rating on the Navigation scale. Skill categories considered more relevant to this study appear on the left.

According to the ratings, intensive, complicated navigation characterizes a very limited number of genres. These genres can be distinguished from first-person games that require movement from point A to point B (normal navigation) but do not allow free navigation deviating from one available route. For instance, many first-person shooters move the player along a fixed path in the same way that cattle are directed through a chute: the player can stop and might even be able to go back through a stage, but cannot meaningfully change paths.

Massively multiplayer online (MMO) games—games that allow many players to interact over the internet—allow free navigation to a much greater degree than standard (locally played) games. This is particularly true of the MMO subgenre of role-playing games (RPGs) such as *World of Warcraft*, with its enormous virtual landscape of cities, lakes, and forests. With an average rating of 8.2 of 10, this subgenre was second only to the tactical shooter subgenre in intensive, complicated navigation.

Environments for online shooter games often are limited to a battlefield or arena with an easily memorized general layout. For this genre, maps typically have not been especially useful. However, shooter games that incorporate more players and larger maps continue to be released. The largest player count in a console shooter currently belongs to the game *MAG*, which has 256-player matches. Larger player counts require larger environments, which in turn tax the ability of players to memorize the terrain through experience alone, encouraging map use. Also, the team-based play of these MMO shooters usually is focused on communicating information about very specific areas in the environments. Due to some of these elements, the major genre category of shooters received a mean rating of 7.8 out of 10 for navigation.

Vehicle simulation games (especially flight simulations), adventure, action-adventure, and RPGs often do feature large, freely navigable environments. It is possible to play many of these games without accurate navigation by wandering until one stumbles across a particular place, item, etc. Yet having and using a map allows one to take the shortest and safest routes. Thus, many games featuring large, freely explorable environments reward players who make good navigation decisions. Massively multiplayer/online/ persistent versions of games in these genres (those in which the game world is hosted by the company and continues to exist as players sign in and out) are truly enormous, drastically compounding the challenges of wayfinding. These games are some of the most popular games currently available.

Based on findings from the task analysis, I predicted a strong relationship between map-based wayfinding skills and the playing of games incorporating maps and large, freely navigable open environments. This kind of game includes many adventure, action-adventure, and role-playing games. Because vehicle simulations (e.g., flight simulators) tend to use navigation aids (particularly compass headings and maps), I predicted that playing simulator games also would be related to map-based wayfinding. First-person shooters often tend to require fast processing of visual-spatial information but only online versions make heavy use of maps and require long-term encoding of game areas. In single player mode, one's path usually is determined by the game. For these reasons, I did not expect first-person shooter playing to be related to map-based or memory-based navigation skills, despite the fact that these games do incorporate many of the necessary elements, particularly in online modes.

Armed with this information obtained through the task analysis, I created a number of questionnaire items used in Study 1. I also used some of these measures in the design of Study 2.

## STUDY 1: ONLINE QUESTIONNAIRE

## CHAPTER II

### METHOD

#### Overview

I designed the online questionnaire prior to Study 2 and used a small, preliminary subset of the data reported here to make decisions regarding that study. The majority of the data collection was accomplished concurrently with Study 2, although the samples do not overlap. The data allow me to approach similar questions using two distinct methodologies (i.e., a self-report questionnaire and training with real-world testing). A major advantage of an online questionnaire is the ability to recruit a more diverse sample of participants (on education level, SES, ethnicity, citizenship, age, etc.) than might be available locally. Online questionnaires allow rapid collection of a large amount of data, providing the statistical power to detect group differences that are not apparent in studies using smaller, local samples. Also, because the participants in Study 2 were to be non-game players, the questionnaire allowed me to collect information specific to the game-playing segment of the population.

It is also worth noting that a major purpose of distributing this questionnaire online was to further develop scales for future studies. Although many of the items had clear face validity considering the constructs we were attempting to measure (VG experience, map-based navigation skill, memory-based navigation skill, and early navigation experience), the questionnaire was intended to cast a wide net that would allow me to select the best performing groups of items. The range of questions included everything from how often people played video games and their attitudes towards games, to questions about past wayfinding experiences (e.g., being allowed to explore outside without a parent present) and how urban/rural participants' neighborhoods were when they were children. This strategy of using a broad range of questions came with the understanding that many of the items might not end up contributing to the final scales.

#### Participants

Participants were recruited through departmental, professional organization, and alumni association e-mail listservs, through a television news story about the research, by posts on



various internet blogs and message boards (video game boards and other hobby sites), through other websites allowing the advertisement of events to large groups of people (e.g., Myspace, Facebook, Craigslist, etc.), and by flyers distributed on campus, in the surrounding community, and to friends and colleagues. In each case, participants emailed the principle investigator for more information or followed a link to the study website where they could submit their contact information. The questionnaire also included a button at the end that allowed participants to “refer” others by emailing them the link to the study website.

In total, 882 individuals signed into the on-line questionnaire and proceeded past the informed consent document. Of those, 771 adults aged 18-75 years ( $M = 30.8$  years;  $SD = 12.0$ ) were retained in the final sample. The final sample was 57% female and 43% male. The data from 104 participants were not used due to excessive missing data (i.e., filling out less than half of the questionnaire). The data from 3 more participants were identified and removed due to repetitions in the IP addresses registered when taking the questionnaire, which were used to ensure that the same participant was not maliciously generating multiple random responses (there was no evidence of this). The 3 dropped cases resulting from IP repeats appeared to all result from participants not completing the questionnaire and returning to re-do it later (i.e., the earlier questionnaire responses were not finished and therefore dropped; the completed questionnaire from the same IP address was kept). The remaining 4 dropped participants reported birth dates outside the age range recruited for the study (18+ years). Participants were told the age requirement at the outset. To avoid fabricated birth dates, I only asked them to enter their birth date at the end of the questionnaire amongst questions about other demographic variables. During the study, the online collection site was changed from Survey Monkey to REDCap, and an error was made in the response options for one of the questions. This error affected 58 participants and their data for that question was left blank for all analyses.

Participants in the final analysis represent 30 countries. The four with the most respondents were the United States (641), Canada (26), Australia (12), and the United Kingdom (12). [Figure 1](#) shows the distribution of participant zip codes throughout the continental U.S.; 46 of the 50 states are represented. Participants were primarily Caucasian (86.0%) with other races/ethnicities reported as Asian (4.1%), African (3.8%), Hispanic (1.9%), Native American (0.3%), and Hawaiian or other Pacific Islander (0.3%).

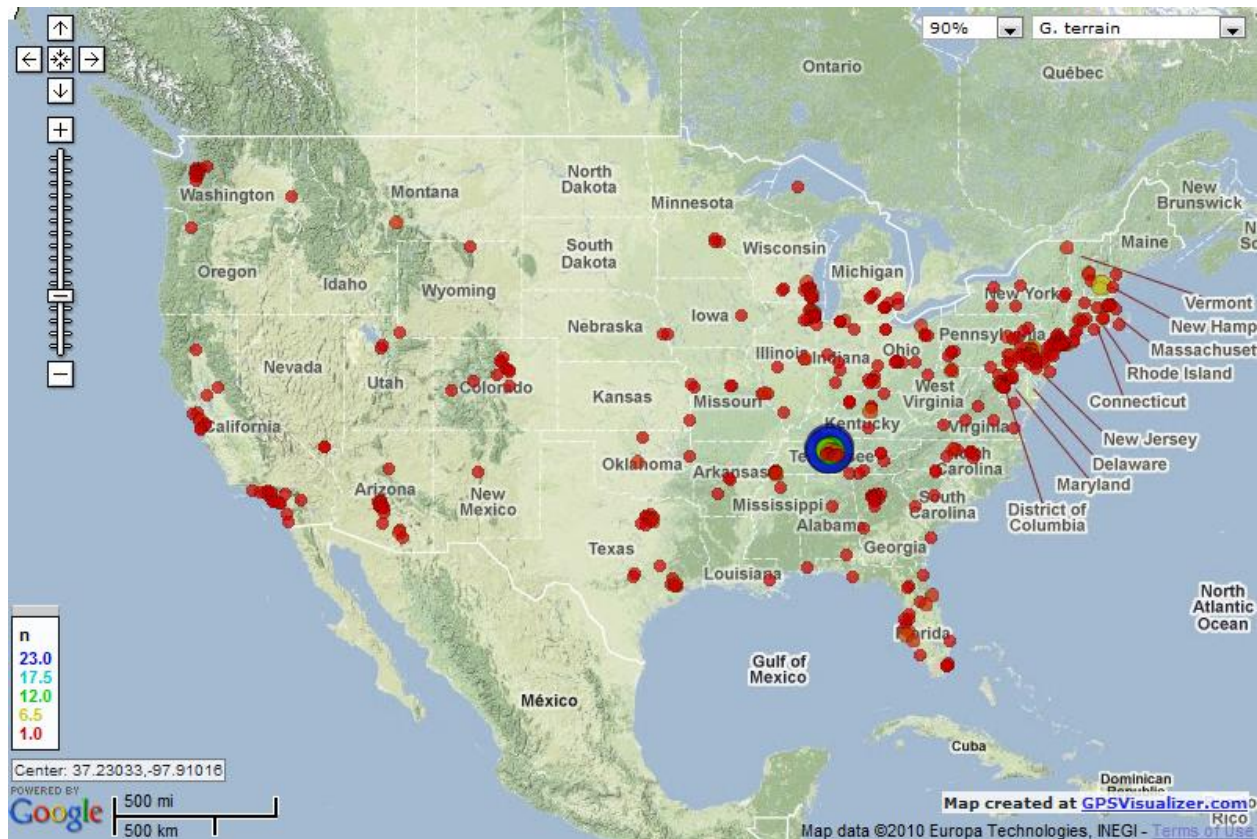

Figure 1. Distribution of Participants from Study 1 (Only participants from U.S. portrayed)

Participants provided responses involving a number of other demographic variables. Household incomes were reported on a scale from 1 – 6 (1 = less than \$20,000, 6 = \$100,000-\$150,000). With a mean of 3.79 ( $SD = 2.07$ ) and median of 4, participants' household incomes averaged around \$60,000 per year. Using data from the 2000 census, the average median income for participants' zip codes is \$51,738 ( $SD = \$22,230$ ). Considering the 2000 census is now more than 10 years old (2010 census data is not yet available), the zip code data and income estimate data agree reasonably well. According to a report by the U.S. Census Bureau sampling 100,000 households, the median income in 2009 was \$49,777 (90% C.I.  $\pm$  \$350) per household. Clearly, the average income bracket of my sample was middle or upper-middle class, but the variability in the sample is significant, including participants with a wide range of income levels. Education levels were reported on a scale of 1 through 8 (1 corresponding to some high school and 8 corresponding to a Ph.D. or other professional degree). Participants reported a mean education level of 4.89 ( $SD = 1.97$ ) and a median of 5, which is roughly equivalent to a bachelor's degree.

## Procedures

Once participants visited the link distributed through the recruiting methods, they arrived at a web page describing the questionnaire in detail and allowing them to provide informed consent to participate. At the bottom of this page, participants were asked to check a box if they wanted to proceed. Those choosing to continue were guided through approximately 80 questions. Participants who reported playing no video games could skip the video game preferences section (13 items) because it asked specific questions about games and gaming preferences that would be inappropriate for non-gamers. Once participants finished the main sections of the questionnaire, they accessed a final page containing requests to forward the link for the study on to acquaintances and to provide feedback to help improve future studies and recruitment procedures. At the onset of the questionnaire, participants were informed that it would take approximately 30 minutes to complete, although from piloting and feedback given on the questionnaire, the time to completion was actually closer to 15 minutes for most individuals.

## Measures

The questionnaire was made up of 80 questions arranged in 6 main sets: *Technology use*, *Opinions and practices*, *Video games*, *Video game preferences*, *Santa Barbara Sense of Direction Scale* (SBSODS—Hegarty, Richardson, Montello, Lovelace, & Subbiah, 2002), and *General information*. [Appendix B](#) provides a summary of the categories and format of questions.

The self-report data yielded by this on-line questionnaire from a self-selected sample introduces some concerns regarding validity. However, substantial efforts to disseminate the survey broadly helped ensure variety in the individuals completing it. A primary goal in Study 1 was to recruit a more varied sample than the individuals who participated in Study 2 (which focused on local, non-game players able to get to Centennial Park in Nashville, TN). Significant variability in the answers to the vast majority of questions, especially the demographic variables, indicates that my sample is at least heterogeneous. Data from Study 2 also allowed for a more direct investigation of the validity of some questionnaire scales.

## CHAPTER III

### RESULTS

#### Factor Analysis

The large number of participants afforded the power necessary to perform a factor analysis on the data to create related scales and get reliability information for this sample. In constructing the questionnaire, I expected 4 scales to emerge: *Video Game Experience/Skill*; *Map-Based Navigation Experience/Skill*; *Memory-Based Navigation Experience/Skill*; and *Early Navigation Experience*. Although the commonly used Santa Barbara Sense of Direction Scale (SBSODS) was designed as a single scale, some of its questions were not expected to load together when combined with my additional questions. Specifically, in Hegarty et al.'s (2002) original analysis of the SBSODS data, 5 of their 15 items did not load on the main factor. They had a reasoned approach for including the additional items, in light of the small sample size used for the factor analysis. Most of these SBSODS items specifically referenced maps, navigational planning (which usually includes maps and other navigation aids), and survey knowledge (which people often attain with the help of maps). My questionnaire included map experience/skill items and additional memory-based navigation experience/skill items that I developed. Therefore, I expected the SBSODS items to divide across two factors in my analysis: the *memory*-based navigation items that loaded heavily on Hegarty et al.'s "sense of direction" factor and "map-related" items that would be more closely related to my *map-based* navigation skill factor. I expected this separation due to differences in the skills required and experiences obtained by individuals using maps to traverse unfamiliar areas, compared with more general memory-based skills involved in having a good sense of direction: integrating and updating heading, distance, and landmark information, which imply the ability to recall (or at least maintain) prior information for navigational planning. Therefore, the SBSODS was expected to break along the distinction between memory and map-based navigation.

The factor analysis (FA) specified 4 factors and included data from a sample of 771 participants on 59 variables, exceeding most rule-of-thumb guidelines for factor analysis (e.g., a 10:1 ratio of sample size to variables). Cases with apparently random missing data were excluded pairwise resulting in a sample size of > 738 for every variable except for one. The

missing data (described earlier under Participants) was due to a copying error for a test form. Nevertheless, I still had data for 706 participants for that question. Items were reverse scored so that high numbers corresponded to an endorsement of more skill, experience, instruction, etc. Prior to factor analysis, all data were converted to z-scores in order to equate open-ended items and items on 5- and 7-level Likert scales.

I used the Principal Axis Factors method of extraction, which is preferable to Principal Components Analysis in this situation because it only analyzes shared variance and it accounts for measurement error. It is therefore less likely to overestimate the variance explained, particularly when communalities are moderate (Costello & Osborne, 2005). Extraction was followed by promax rotation, an oblique rotation method that allows the factors to be correlated. I utilized this approach because I expected a number of the factors to be moderately correlated (e.g., playing video games and engaging in other spatial activities) and because orthogonal rotation, in those instances, leads to a loss of information and results that are not as easily reproduced (Costello & Osborne, 2005). If the factors were in fact orthogonal, an oblique rotation method would closely approximate an orthogonal solution and correlations between factors would simply be close to zero (Fabrigar, Wegner, MacCallum, & Strahan, 1999).

The Kaiser-Meyer-Olkin (KMO) value for the initial FA was adequate (.92) and the Bartlett Test of Sphericity was significant ( $\chi^2 = 18505.7$ ,  $df = 1711$ ,  $p < .001$ ). The 4 specified variables all had Eigenvalues over 1 and the scree plot had a break after these first four factors, indicating that I had not missed any meaningful scales in specifying only 4 factors.

Item selection proceeded through an iterative process. From the initial factor analysis, all items with factor loadings of less than .6 or with cross loadings of more than .4 were removed from further analysis. Additionally, two items were removed from Factor 1 because they were not related to the rest of the scale in the expected direction (these involved having accounts on online gaming sites and for the game *World of Warcraft*). Specifically, there were negative relations between these items and interest/experience with other games. It seems possible that individuals endorsing these items tended to score low on other video game questions because of their focused interest in a single type of gaming experience. These were relatively low instance endorsements and the items had limited variability within the sample. Whatever the cause, the factor loadings for these items were relatively marginal given the strength of other loadings from the scale, and the face validity of the resulting scales would suffer if these items were retained.

The 27 items that did not meet the above FA criteria are reported in Table 2. One can speculate why some of the items did not cohere. For example, many of the navigation items involved owning or having regular access to maps and other navigational aids (e.g., GPS). There are multiple reasons why an individual might have or not have or use such items. Individuals who believe they are bad at navigating but travel regularly would be more likely to invest in a GPS system, whereas those who believe they are good navigators may be very interested in maps

Table 2. Questionnaire Items Removed During Factor Analysis

	Question
Video Game Questions	VG Console Score (points awarded for owning gaming consoles according to the relative age of the console)
	Do you have an account with a massively multiplayer online game (e.g., World of Warcraft, Everquest, etc.)?
	Do you have an account with Gamefly or another internet-based video game service that delivers video games to your home?
	Do you have an account with any online gaming sites (e.g., travian.com, trendio.com, shockwave.com)?
	I think that video games can teach important skills.
Navigation Questions	It's not important to me to know where I am -reversed
	When in a new place, I like to have a map so I know where I am.
	I know how to use a map very well.
	I sometimes have trouble understanding what maps in newspapers or on the TV news are showing -reversed
	Maps that show elevation using sets of contour lines (i.e., topographic maps) are really hard for me to understand -reversed
	I read maps or diagrams regularly as part of my job.
	Do you have a road atlas or other maps in your vehicle?
	Do you own a globe or have wall maps/charts in your house?
	Do you use any or all of these: Mapquest, Google maps, Google earth, or other computer based map systems?
	Do you own a hand-held GPS?
Do you have a GPS navigation system (such as a TomTom or Garmin) in your vehicle?	
I often have trouble figuring out where I am when I use a map -reversed	
Visual-Spatial and Navigation Experience	I currently participate in organized sports.
	In school, I received a lot of instruction in how to read maps.
	I played with a lot of construction toys (e.g., Legos, K'nex, etc.) as a child.
	I built a lot of jigsaw puzzles as a child.
	I spent a lot of time exploring outdoors as a child.
I was regularly allowed to play/explore outside without a parent present.	
Santa Barbara Sense of Direction Scale	SBSODS03 - I am very good at judging distances.
	SBSODS02 - I have a poor memory for where I left things.
	SBSODS05 - I tend to think of my environment in terms of cardinal directions (North, South, East, West).
	SBSODS07 - I enjoy reading maps.

and may have built navigation skills by regular exposure to navigational aids. Both might report owning and using navigational aids, yet they might have very different scores on Factor 2 (self-report of map-based navigation experience/skill).

The final factors, factor loadings, and reliability information for the scales based on the 32 variables that passed the above criteria are reported in [Table 3](#). The retained scales were: 1. *Video Game Experience*, 2. *Navigation Skill*, and 3. *Advanced Map Instruction*. Factor 4 was rejected for several reasons discussed below. The final factor structure was only slightly different from the expected structure. I expected Factor 3 to retain more of the items, specifically those referring to maps, that became a part of Factor 2, and I expected more of the questionnaire items to load on the dropped Factor 4. Factor 2 became more of a “general navigation” factor encompassing both memory-based and map-based navigation items. Although a case can be made for these two types of navigation being theoretically distinct, it seems likely that people cannot differentiate between the two in judging their own level of skill. In reality, even though these types of navigation rely on some different skills, individuals navigating to novel locations will almost always rely on strategies encompassing both sets of skills.

For Factor 4, I initially had predicted that questions related to childhood experiences, such as opportunities for self-navigation, urban vs. rural rearing environment, and other activities that might foster better navigation skill (e.g., access to spatial toys and activities), would combine to create an “Early Navigation Experience” factor. For the most part these questions did not cohere and Factor 4 became an amalgam of similarly worded items related to the rural/urban character of participants’ childhood and current living environments. My hypothesis was that children or adults who lived in more rural environments would report better navigation or more navigational experience (due to fewer parental safety concerns and larger distances to travel). Because these multiple urban/rural items did not load as expected with the few other early experience items, I rejected the 4<sup>th</sup> factor entirely. Reliability analyses of the results of Study 2 confirmed that this was a reasonable decision. However, I used some of the questions that I expected to load on the “early navigation experience” factor in exploratory analyses to determine whether future versions of the questionnaire should include an improved line of questions in that area.



Table 3. Factor Analysis Loadings, Factor Reliability, and Final Scales

Factor Name and Factor Reliability	Question	Item-Total <i>r</i>	Factor Loading
1. Video Game Experience Study 1: $\alpha = .94$ Study 2: N/A	I probably play video games more than most people my age.	.855	.894
	I often stay up later than I should playing video games.	.819	.834
	I prefer playing video games to outdoor activities.	.753	.805
	I spend more of my money on video games and video game equipment than the average person my age.	.764	.798
	I have played video games for more than 8 hours straight.	.785	.797
	I would rather read or watch TV than play a video game. - reversed	.772	.793
	I am better than my friends at most video games.	.750	.770
	I enjoy playing video games.	.734	.750
	I am or have been part of a gaming clan, guild, or club.	.688	.697
	Video games sometimes get in the way of work I have to do.	.669	.695
	On average, I spend more time watching TV than playing video games. – reversed	.653	.662
	I worry that I spend too much time playing video games.	.611	.637
	I think that video games are a waste of time. – reversed	.602	.619
	2. Navigation Skill Study 1: $\alpha = .91$ Study 2: $\alpha = .86$	SBSODS04 - My "sense of direction" is very good.	.774
SBSODS01 - I am very good at giving directions.		.703	.749
SBSODS15 - I don't have a very good mental map of my environment. - reversed		.648	.729
SBSODS06 - I very easily get lost in a new city. - reversed		.676	.726
SBSODS13 - I usually let someone else do the navigational planning for long trips. – reversed		.683	.689
SBSODS11 - I don't enjoy giving directions. - reversed		.605	.672
SBSODS09 - I am very good at reading maps.		.682	.662
SBSODS08 - I have trouble understanding directions. - reversed		.618	.646
SBSODS14 - I can usually remember a new route after I have traveled it only once.		.599	.639
SBSODS10 - I don't remember routes very well while riding as a passenger in a car. – reversed		.579	.625
3. Advanced Map Instruction Study 1: $\alpha = .75$ Study 2: $\alpha = .72$	I often have trouble figuring out where I am when I use a map. - reversed	.621	.617
	I have taken orienteering courses and/or competed in orienteering competitions.	.582	.734
	Using a compass, I am able to find my position on a map by measuring the angles between my location and distant landmarks (i.e., I know how to triangulate a position).	.588	.678
	I received instruction in how to read maps outside of school (e.g., in the Boy/Girl Scouts).	.518	.646
4. Environment Study 1: $\alpha = .75$ Study 2: $\alpha = .34$	I have had formal training in mapping and navigation (e.g. military, geology, geography, aircraft piloting, etc.)	.502	.587
	I would describe the place I grew up in as an urban area (a city) - reversed	.564	.704
	I would describe the place I grew up in as rural.	.532	.657
	I would describe where I currently live as an urban area (a city) - reversed	.545	.633
	I would describe where I currently live as rural.	.534	.614

Study 1:  $N = 759$ , Study 2:  $N = 78$



Table 4. Study 1 Factor Correlations

Factor		1	2	3
1	<i>r</i>	1.000		
	<i>p</i> (df)	-		
2	<i>r</i>	<b>.114</b>	1.000	
	<i>p</i> (df)	.00 (766)	-	
3	<i>r</i>	<b>.191</b>	<b>.291</b>	1.000
	<i>p</i> (df)	.00 (766)	.00 (767)	-

As expected, some of the final factors were significantly correlated, but all correlations were less than .3 (see Table 4). Because the factors were allowed to be (and were) correlated using an oblique rotation, it is not possible to calculate an accurate percentage of the total variance explained by the scales. (Total variance explained is calculated from sum of squares loadings, which cannot accurately be added when factors are correlated—Costello & Osborne, 2005). Considering factors 2 and 3 are made up entirely of items having to do with navigation skills (with or without maps), it is not surprising that these scales are the most highly correlated.

It should also be noted that Factor 2 of this analysis was highly correlated with the original 15 items from the SBSODS in both Study 1 ( $r(748) = .97, p < .001$ ) and Study 2 ( $r(78) = .96, p < .001$ ), which is not surprising considering the number of items from Factor 2 that were taken from that scale. The power of this FA is greater than the original FA by Hegarty, Richardson, Montello, Lovelace, and Subbiah (2002) and provides converging evidence for the validity and reliability of many of the items from that scale; the original 15 SBSODS items had good reliability and item-total correlations in Study 1 ( $\alpha = .90$ , item-total  $r = .30$  to  $.78$ ) and Study 2 ( $\alpha = .86$ , item-total  $r = .26$  to  $.69$ ) and scores were related to the real-world navigational testing scores. However, results from the current studies also suggest that the Factor 2 items create a navigation scale that is shorter than the SBSODS, has equally good reliability and validity, and is a purer measure of the construct. More results concerning the reliability and validity of the questionnaire scales are presented in Study 2.

### Game Player Characteristics

Game players among the participants tended to be male ( $r = .513, p < .001$ ), younger ( $r(740) = -.183, p = .007$ ), have lower income ( $r(707) = -.169, p < .001$ ), lower levels of education ( $r(739) = -.183, p < .001$ ), more computer ownership ( $r(766) = .167, p < .001$ ), and engage in more non-work-related internet surfing ( $r(757) = .246, p < .001$ ). After controlling for age and gender, education was no longer correlated with video game playing, but income, computer ownership, and internet surfing remained statistically significant (partial correlations respectively,  $N = 534$ , were  $r = -.152, p < .001$ ;  $r = .169, p < .001$ ;  $r = .247, p < .001$ ).

Although a benefit of factor analysis is the simplification of individual items into coherent scales, it is important to determine whether individual items within a factor may be highly correlated with other items, particularly those not used in the factor analysis. I did individual-item analyses as an exploratory attempt to ensure the factor structure did not oversimplify the results or conceal a potentially interesting pattern of correlations. However, these analyses agreed closely with the pattern of results found using the factors and did not add meaningfully to the interpretation of the data.

### Genre Analyses

I examined the extent to which preferences for specific VG genres were related to the scales from the questionnaire by having participants who indicated that they play video games rank their preference for playing 9 different genres (Shooter, Sports, Action, Strategy, Adventure, Role-Playing, Simulation, Music/Rhythm, and Other). Participants were asked to rank (1-9) each genre without re-using a rank. Genres ranked higher were more enjoyable to the participant.

As can be seen in [Table 5](#), the direction and magnitude of correlations between the genre rankings and scores on the Video Game Experience factor (Factor 1) indicate that those who play games more (i.e., score higher on Factor 1) tend to rank role-playing, shooter, adventure, and strategy games among their favorite genres. Those who play less (i.e., more “casual gamers” as they are known in the industry) were more likely to rate Sports and Other types of games (Solitaire, Pac-Man, Brain Age series, Minesweeper, Portal, Puzzle games) higher. Despite video game experience being linked with preferences for certain genres, genre preferences were

Table 5. Partial Correlations Between VG Genre Preferences and Questionnaire Factors with Gender as a Covariate

Factor	Genre Rankings									
	Shooter	Role-Playing	Strategy	Simulation	Action	Other	Sports	Adventure	Music/Rhythm	
1 – VG Exp	<i>r</i>	<b>.209</b>	<b>.462</b>	<b>.121</b>	-.105	-.105	<b>-.205</b>	<b>-.346</b>	<b>.146</b>	.006
	<i>p</i>	<b>.00</b>	<b>.00</b>	<b>.04</b>	.07	.07	<b>.00</b>	<b>.00</b>	<b>.01</b>	.92
2 – Navigation	<i>r</i>	.049	<b>-.132</b>	.098	.022	-.007	.005	-.020	-.015	-.043
	<i>p</i>	.40	<b>.02</b>	.09	.70	.91	.93	.73	.80	.46
3 – Adv Map Instruction	<i>r</i>	.017	-.042	<b>.149</b>	.039	-.036	-.026	-.039	-.039	-.057
	<i>p</i>	.77	.46	<b>.01</b>	.50	.54	.65	.50	.49	.32
Santa Barbara SODS	<i>r</i>	.067	<b>-.119</b>	<b>.113</b>	.007	-.019	.019	-.022	.004	-.068
	<i>p</i>	.25	<b>.04</b>	<b>.05</b>	.90	.74	.74	.70	.94	.24

Genre rankings are ranks of participants' favorite genre from 1-9 (favorite = higher rank)

not strongly related to reports of navigation ability (bottom 3 rows of Table 5), once I controlled for gender.

The above analyses take into account players' interest/enjoyment of the different genres, but do not take into account the amount of time spent playing each genre; someone who rates shooter games as their favorite but only plays 1 hour per week will have much less experience than someone who gives the same rating but plays 10 hours per week. To approximate the amount of time spent playing, I assigned participants a score from 1-9 corresponding to where they fell in the distribution of scores on the Video Game Experience scale (with a score of 9 given to the highest scoring 1/9<sup>th</sup> of participants). I multiplied this number by participants' rankings of genre to provide a number corresponding to the amount that participants are likely to have played a genre (based on how much they play video games in general and how much interest they have in that specific genre). These correlations had a similar pattern to those reported above, but were attenuated (see Table 6).

Table 6. Partial Correlations Between Estimated VG Genre Exposure and Questionnaire Factors with Gender as a Covariate

Factor	Estimated Genre Exposure									
	Shooter	Role-Playing	Strategy	Simulation	Action	Other	Sports	Adventure	Music/Rhythm	
2 – Navigation	<i>r</i>	.061	<b>-.127</b>	.050	.090	.003	.018	-.003	.010	.016
	<i>p</i>	.29	<b>.03</b>	.38	.12	.96	.75	.96	.87	.79
3 – Adv Map Instruction	<i>r</i>	.068	-.010	<b>.117</b>	.049	.014	.026	-.029	.002	-.006
	<i>p</i>	.24	.86	<b>.04</b>	.39	.81	.65	.62	.98	.92
Santa Barbara SODS	<i>r</i>	.090	-.102	.077	.085	.007	.024	.001	.037	-.006
	<i>p</i>	.12	.08	.18	.14	.91	.67	.98	.52	.91

Genre exposure is... x ranks of participants' favorite genre from 1-9 (favorite = higher rank)

### Sex Differences

Males reported higher scores than females on all 3 factors from the questionnaire. Effect sizes ranged from medium (navigation skill:  $M(SD) = .19(.64)$  and  $-.14(.74)$ ,  $t(721) = -6.5$ ,  $p < .001$ ,  $d = .47$ ) to large (advanced map instruction:  $M(SD) = .28(.85)$  and  $-.23(.59)$ ,  $t(532) = -9.3$ ,  $p < .001$ ,  $d = .72$ ; video game experience/skill:  $M(SD) = .46(.71)$  and  $-.35(.63)$ ,  $t(631) = -16.0$ ,  $p < .001$ ,  $d = 1.20$ ). Initially, video game playing appeared to be related to navigation skill and advanced map instruction ( $r(766) = .11$ ,  $p = .002$ ;  $r(766) = .19$ ,  $p < .001$ ), but these correlations are not significant after controlling for gender. Although males do report playing more video games and having better navigation skills, the pattern of data from Study 1 is not what one would expect if video games are helpful in teaching navigational skills or if video games are even partially responsible for the observed gender differences in navigation (at least when considered as a whole).

### Early Spatial/Navigation Experience

Although the few questions I asked related to early spatial experience did not cohere in the factor analysis as expected, I did some exploratory analyses in the interest of potentially developing the measure in future studies. Therefore, to create an index of early spatial experience, I added scores on 4 items together: 1) I built a lot of jigsaw puzzles as a child; 2) I

played with a lot of construction toys (e.g., Legos, K'nex, etc.) as a child; 3) I spent a lot of time exploring outdoors as a child; 4) I was regularly allowed to play/explore outside without a parent present.

Males were more likely to endorse the items regarding construction toys ( $M(SD) = 1.41(.90)$ ,  $M(SD) = .50(1.23)$ ,  $t(732) = 11.5$ ,  $p < .001$ ,  $d = .91$ ) and being allowed to play outside without a parent present ( $M(SD) = 1.35(.93)$ ,  $M(SD) = 1.18(1.10)$ ,  $t(723) = 2.33$ ,  $p < .05$ ,  $d = .17$ ), whereas females were more likely to endorse having spent time building jigsaw puzzles ( $M(SD) = .29(1.13)$ ,  $M(SD) = .60(1.16)$ ,  $t(685) = 3.70$ ,  $p < .001$ ,  $d = .31$ ). Due to these differences I used partial correlations controlling for gender and found that the sum of these early experience items was correlated with Factors 2 (Navigation) and 3 (Advanced Map Instruction) from the questionnaire ( $r = .26$  and  $.15$ ,  $df = 721$  and  $p$ 's  $< .001$ ), but was not correlated with Video Game Experience (Factor 1). Although exploratory, these correlations indicate that early spatial experiences and experience with self-directed navigation, regardless of sex, may be important for later navigation ability. Increasing the number and variety of items and creating a better measure may help clarify this relation in future studies.

## CHAPTER IV

### DISCUSSION

The factor analysis produced 3 questionnaire factors similar to those expected a priori based on the design of the items. The retained factors all have reasonably good reliability ( $\alpha \geq .75$ ) and were correlated in the expected ways with many of the other variables. The use of these factors in combination with data from Study 2 will allow me to further assess the validity of these scales and determine how they relate to my real-world test outcomes.

Analyses related to specific genres of games indicate that players with more video game experience are more likely to rank Role-Playing, Shooter, Adventure, and Strategy games among their favorite genres, whereas those who play less tend to have a greater interest in Sports and Other types of games (*Solitaire, Pac-Man, Brain Age series, Minesweeper, Portal*, puzzle games). However, these game preferences do not appear to be strongly related to reports of navigation ability.

There are a number of reasons my initial hypothesis was not supported. A primary motivation for this study was the observation that video game playing is replacing outdoor leisure time activities. My question was whether navigating in video games might relate to people's reports that they were good at real-world navigation. However, to the extent that playing games is replacing, as opposed to supplementing, other important spatial/navigational experiences (i.e., if there is an opportunity cost for players), one may not expect a strong correlation between playing and navigation skill. This possibility was one motivation for the training paradigm used in Study 2 and one of the primary reasons these studies were planned and executed concurrently. Additionally, there were challenges in using genre categories to assess navigation experience. In my Video Game Task Analysis, the relatively broad genre categories encompassed a range of game designs, and most players did not focus solely on one type of game.

In retrospect, the design of the video game genre questions may have placed limitations on the conclusions I can draw from the preference data. I thought it would be advantageous to make individuals strictly rank their interest in genres, but this method did not capture *how much time* people actually spend playing each of the genres. I attempted to estimate time spent with

various genres based on Factor 1 scores and genre preferences; however, future attempts to examine how genre preference influences spatial skill/navigation might have gamers estimate the percentage of time that they play specific genres. Using the requirement that the percentages add up to 100% would help ensure that participants make distinctions between genres and, in combination with questions involving the total number of hours participants play, this method would allow for better estimates of how much time individuals actually spend playing games in each category.

Although there are obvious concerns with self-report measures (many of which are addressed in Study 2), the data from the questionnaire is in general agreement with much of the literature regarding sex differences in navigation ability and interest in video games, with males reporting more skill/interest in both areas. However, although males reported more skill/interest, the data from Study 1 are not consistent with what would be expected if video games were helpful in teaching navigational skills or partially responsible for the observed sex differences. That is, gender appears to fully mediate the relationship between video game playing and reported navigation skill because males tended to report both a greater interest in video games and better navigation skills. Sex differences also mediate the relationship between genre preferences and navigation skill and, therefore, an experimental design is necessary to determine causal links between game playing and navigation skill.

Finally, the exploratory analyses regarding early spatial experience indicate that self-guided navigation and spatial experiences may be important for developing navigational skills regardless of gender. However, the need to recall events from childhood may make it very difficult to construct a measure that participants will be able to respond to reliably and that will act as a valid measure of those early experiences. Any future attempts at capturing this construct will require identifying a larger pool of items that more completely capture a wide range of early spatial experiences.

In summary, the questionnaire in Study 1 produced 3 reliable factors for self-report assessment of game playing and navigation skills. Although the data appeared to show promising trends indicating a relationship between navigation skills and video game playing (both total and for playing certain genres), sex differences in reported navigation skill and game playing affinities are primarily responsible for those relationships. Study 2 was designed to complement this research by providing a set of real-world test data for assessing the validity of

the navigation factors from Study 1, controlling for sex differences through sampling, and controlling for the amount and type of video game play by experimentally manipulating those variables.



## STUDY 2: VIDEO GAME TRAINING EXPERIMENT

## CHAPTER V

### METHOD

#### Overview

In the training study, 3 groups of 20 non-game-playing adults participated in pre- and post-tests. Between testing sessions they received varying amounts and types of at-home video game experience: 10 hours playing a game using a map, 10 hours playing a spatial puzzle game, or no game play (control group). This manipulation was used to assess the impact of video game playing on a range of real-world, computer, and pencil-and-paper tests of navigation and other more basic visual-spatial skills. The experimental manipulation was intended to help clarify results from Study 1, replicate prior research on the training of visual-spatial ability from video games, and to establish how useful video games may be for teaching skills transferable from virtual environments to unrelated real-world environments.

#### Participants

Sixty adults (mean age 24.6 years; range = 18.4 – 33.8 years;  $SD = 4.2$ ) participated in one of 3 groups (*Experimental - Elder Scrolls*; *Control 1 - Portal*; *Control 2 - Non-playing*). Potential participants were pre-screened (see Measures) to determine the extent to which they currently played video games, and were excluded if they reported having played more than an average of 3 hours per week in the past 3 months. Of the 60 participants who were retained (40 females; 20 males), 44 reported playing less than 1 hour per week and only 3 reported playing 2 or more hours. Additionally, potential participants were asked how many of these hours were spent playing two kinds of video games that were expected (based on the preliminary task analysis) to be important in the development of the skills being tested: 1) first-person shooter games in which the video screen shows the viewpoint of the character as he/she looks around or moves (examples are *Halo*, *Doom*, *Wolfenstein*, and *Call of Duty*), and 2) video games (often role-playing games) with in-game or paper maps that the player can use to navigate in a large game world (examples are *World of Warcraft*, *Zelda*, *Grand Theft Auto*, and *Burn-Out: Paradise*). Anyone who played more than one hour per week of those types of games was excluded. Only 9 people in the sample reported having played games such as these, and the most

time reported was 6 hours over the last 3 months (less than ½ hour per week). In reporting their game play, potential participants were asked not to include time spent playing cell phone games, simple puzzle and card games included with most computers, or games available from websites such as *Popcap Games*, and music rhythm games such as *Rock Band*, because these are played casually by a large portion of the population and their content is not predicted to relate to learning map and navigation skills (they lack a first-person perspective, life-like graphics, and movement in a 3-D virtual environment).

Approximately 225 individuals filled out the screening questionnaire, 27.4% of whom did not qualify because they had too much game experience. Another 20-30% were disqualified for having incompatible computer equipment that could not play the training games. The remainder of the screened-but-not-used participants never responded to my attempts to schedule them or opted not to enroll. It is likely that these screening procedures resulted in the selection of a younger (discussed below) and higher SES sample than the average. Higher-end computer equipment that could play the games likely is owned by people with more discretionary income. I decided that the advantages of an ecologically valid training period in participants' homes (as opposed to in-lab training) offset any additional restrictions created by the computer requirements. Using young adult participants who normally do not play video games disqualified a much more significant portion of the population: 60% of U.S. households own video game consoles (Deloitte, 2010) and reports of 80% of 18- to 29-year-olds being players are not uncommon (e.g., Pew Internet and American Life Project, 2008). Thus, only a minority of the population qualified for this training study.

Participants included 16 Vanderbilt undergraduates, 5 undergraduates from other nearby universities, and 8 Vanderbilt graduate students. The remaining 31 participants were adults recruited from the local community. Of the 60 participants, 45 were Caucasian, 6 were African/African-American, 4 Asian/Asian-American, 1 Native American, and 3 people identified themselves as Hispanic. Advertisements specifically asked for non-game players to reduce the number of inappropriate responses to the screening questionnaire. Ads also included the information that the research involved a video game study about map and navigation skills and that participants might be asked to play a game for up to 10 hours. At no point until they finished the study were participants made aware of specific study hypotheses or what all 3 of the conditions of the study were.

Participants were directed to the screening questionnaire hosted on the study website via advertisements in the Vanderbilt SONA system (subject pool for undergraduates and Nashville residents), from the Vanderbilt Kennedy Center's subject finder, through online advertisements on Craigslist.com, Facebook.com, and Google adwords, via broadcast e-mails to the Vanderbilt community, and through flyers posted on campuses and other locations throughout Nashville. After completing the screening questionnaire, qualifying participants were contacted via e-mail and scheduled.

As compensation, all Vanderbilt students received credit for the campus participant pool. All participants also were offered entry in a drawing for a \$400 gift certificate. The final 34 participants were offered a \$40 gift certificate (given at the end of the post-test) in addition to entry in the drawing and credit. This change did help the recruitment response, but more than doubled the dropout rate. Of the 14 participants who completed Time 1 (T1) pre-testing but did not complete the study, only 5 of the first 44 did not return versus 9 of the final 34. There were no significant differences in the final sample between those who were paid or not. Most dropouts simply did not respond to emails about their playing progress or attempts to reschedule their Time 2 post-testing; of the 3 participants that did respond, 2 cited not having time to complete the 10 hours of game play and 1 had to leave the area unexpectedly for a family emergency. Any participant unable to be contacted and post-tested within 28 days from their pre-test was dropped from the study.

Because non-players were recruited, and all 14 who failed to complete the study were assigned to game playing conditions, the time commitment and game playing task appear to be responsible for the vast majority of dropout. There were no significant differences between those who dropped out of the study and those who remained in the sample for the test battery measures at pretest or any of the demographic or SES variables. Additionally there were no significant group differences between the experimental conditions. Nonetheless, the statistical analyses used for comparing the study groups include T1 test scores as a covariate, which also controlled for minor pre-test differences.

As part of their screening, participants were asked about their computer hardware to try to ensure game compatibility. However, I was not able to install the games prior to having participants arrive at the first testing session, and 11 participants who originally were assigned to a game playing condition had computer problems that prevented them from playing (10 ES and 1

Portal). Presumably because younger people are more likely to invest in computers, there was a relationship between age and computer incompatibility: 3 of the participants with computer issues were among the oldest in the study. They were dropped to equate the groups on age and sex. The remaining 8 participants with computer problems were transferred into the No-Play control group. These non-randomly assigned participants did not significantly differ from other participants in the No-Play group on any of the demographic variables (including age) or on the T1 test battery variables.

### Measures and Materials

A number of standard and self-created measures were used in this study. A table in Appendix C provides a summary of the measures, short descriptions, testing times, and the observed reliability data from this study.

#### Visual-Spatial Measures

I administered a *Mental Rotation Task* (MRT - Shepherd & Metzler, 1971) and the *Motor-Free Visual Perception Test* (MVPT - Colarusso & Hammill, 2003) at pre- and post-test. The MRT that I designed used digitized versions of the stimuli developed by Shephard and Metzler to assess mental rotation ability, presented in pairs on the computer screen (see [Figure 2](#)). Participants had to decide if the two stimuli were the same (could be rotated to match each other) or different. Participants responded using the “S” (for Same) and “D” (for Different) keys on the keyboard. I collected accuracy and reaction time measurements on participants' responses for each of 50 stimulus pairs. Stimulus pairs were randomly presented from a stimulus pool requiring 5 different levels of rotation (10 trials each of 20, 60, 100, 140, and 180 degrees). On screen, the circle around each shape had a diameter of 51mm. Both this task and the Photo-Map Task described below were completed on a laptop computer with a 15.4” display (16:10 aspect ratio; 1280 x 800 resolution).

The MVPT is a standardized flip-book style multiple-choice test of general visual-spatial ability that includes up to 52 test items for adults. Participants typically point to or name a shape that fits some criterion (e.g., find the one item that is different from the others; find the item that could be rotated to match a sample shape; find how many of a certain shape are embedded in an array, etc.). These tasks clarified the extent to which increases in visual-spatial skills are a

Matched Pair - Same

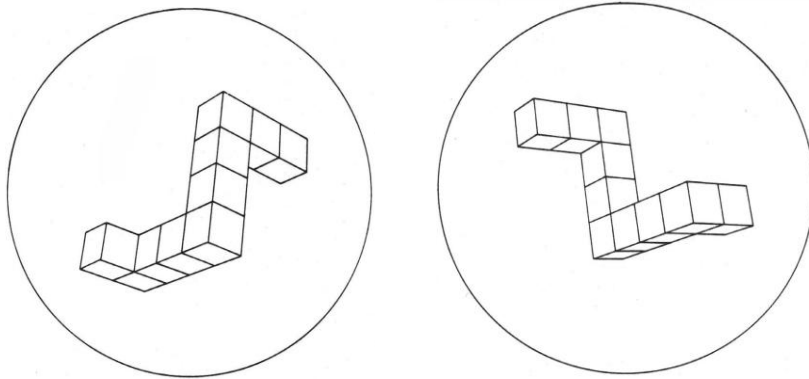

Mismatched Pair - Different

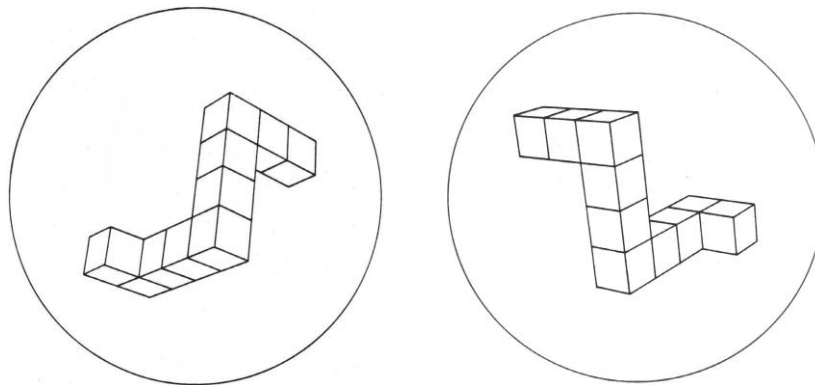

Figure 2. Mental Rotation Task Example

common effect of video game play and how visual-spatial ability relates to acquisition of map-based wayfinding and spatial memory skills from video games. Prior research has shown a connection between wayfinding skills and measures of visual-spatial ability (e.g., Nori, Grandicelli, & Giusberti). Hegarty et al. (2006) suggest that this relationship follows a partial dissociation model (i.e., visual-spatial ability and navigation skills do overlap, but are not analogous) and present some evidence that smaller scale, lower-level spatial skills may be more closely associated with environmental learning from experience with virtual environments and video than from real-world spaces. These measures were included due to the above findings and prior evidence that playing a first-person shooter game increased visual-spatial abilities (Feng et al., 2007). Both measures have been used extensively in the literature as valid measures of

visual-spatial ability and have good reliability. Average scores for the mental rotation task, which were negatively skewed, were corrected using a reversal of the scores and a natural log transformation (equation:  $\ln(1.01 - \text{accuracy})$ ; low scores = better performance). Scores for the MVPT are raw (non-standardized) scores from the test.

### Navigation Measures

The *Navigation and Map Use Questionnaire* is a shorter version of the questionnaire from Study 1 containing only questions relevant to Factors 2 (Navigation Skill) and 3 (Advance Map Instruction). This questionnaire, which also included the *Santa Barbara Sense of Direction Scale (SBSODS)*; Hegarty, Richardson, Montello, Lovelace, & Subbiah, 2002), did not include the Factor 1 questions regarding video game play because non-gamers had been selected as participants. All of the Study 2 items were based on a 7-point Likert scale (whereas Study 1 used 5- and 7-point scales), allowing me to simplify the interpretation of factors for Study 2 by using raw scores for the variables instead of z-scores.

The *Photo-Map Task*, a computer-based and adult-focused adaptation of Liben et al.'s (2002) version, focuses on the ability of participants to determine their location on a map using available visual input from the environment. This ability is essential to map-based wayfinding; incorrect identification of the starting location and current heading likely is a primary source of wayfinding failures when using paper maps (e.g., Levine, Marchon, & Hanley, 1984). I modified this paper-and-pencil, open-ended task into a computerized, 4-answer multiple choice task. I also decided on a self-guided approach to allow automated administration of the test in the future. In an effort to improve the instructions and to ensure that participants understood what they were being asked to do, they were invited to ask questions if they felt unsure after reading the instructions. Only 2 or 3 individuals did so; in all cases, it became clear that they understood but wanted to be sure. Raw data for this task was cleaned at the participant level by removing the accuracy and reaction time (RT) data for any trials in which the RT exceeded 3 *SD*'s from the mean of the participant's RT across trials. This task essentially is in its first stages of development as a multiple-choice instrument for adults (see Results).

The *Real-World Map Test (RWMT)* was intended to measure skills necessary for map-based wayfinding in an outdoor environment, requiring skills such as locating one's current position on a map and identifying the appropriate heading to follow to another location on a map

(Liben et al., 2002). This task has obvious ecological validity; however, due to the environment-specific nature of the task and a lack of standardized procedures, prior reliability data for this type of task using the Centennial Park location is not available. The reliability of similar tasks used in other locations generally has not been reported. Observed reliability statistics from this study are available in [appendix C](#).

The map for the test (see [Figure 3](#)) was a 27 cm x 27 cm laminated square with a scale of 26.5 mm per 100 m in the park. Therefore, the map covered an area roughly 1019 m<sup>2</sup>. Because an up-to-date and spatially accurate map of the park was not available, the map was created by tracing a satellite image of the park to make a geocoded layer of map elements and overlaying those elements onto a Google map of the park location. The relative positions of a number of the elements were checked using GPS, and a tour of the park provided verification that all important sidewalks/roads/landmarks had been incorporated into the map. Locations 1 and 3 in this test (the most distant stops) were separated by approximately 330 m and none of the locations could be seen from another.

The *Real-World Spatial Memory Test* (RWSM), adapted from Hegarty et al. (2006), focuses on the learning of spatial layout information while participants walk through Centennial Park. In prior research, scores on this type of test have been related to the SBSODS (Hegarty et al., 2002) so I expected participants' scores to be closely related to the navigation factor from Study 1, but not to the advanced map training factor. In theory, the RWSM test provides a real-world contrast to the map-based navigation skills tested in the Real-World Map Test.

Unlike most of the versions of this test encountered in the literature, which have been done within buildings, my RWSM test was done outdoors and used a much longer travel route. As a result, participants undoubtedly had to keep track of a more complex visual environment, but also had the benefit of longer sight lines. The ability to see farther distances theoretically could have enabled participants to track many of the tests landmarks over a much longer distance as they traversed the route even though participants could not see any other landmark as they made their judgments. Some of the landmarks came into or went out of view shortly before/after participants arrived at the testing locations. In contrast, when this test is done inside a building, walls would tend to quickly and permanently obscure sightlines as the route is traversed. Although I only rarely noticed participants overtly keeping track of landmarks as we were





Figure 3. Real-World Map Test Park Map

walking, I made no attempt to control their behavior when travelling between landmarks; participants were allowed to use their own navigation strategies as long as they continued to walk alongside me.

### Language Ability

The *Spelling Test*, comprising the spelling subscale of the Woodcock-Johnson III (Woodcock, Mather, & McGrew, 2001), was used as a measure of verbal ability to establish discriminant validity for the spatial measures. Participants were administered 32 items (items 28-59) and were asked to spell the word I gave verbally and used in a sentence. On the assumption that video game training is useful for visual-spatial ability and wayfinding, but not for verbal knowledge, I expected a different pattern of results related to this subscale, compared to the other variables. At Time 1, mean scores on this measure were not correlated with mean scores from any of the other measures except for the Advanced Map Instruction Factor ( $r = -.223, p(78) = .049$ ), an indication that scoring well on the spatial task is not due simply to better verbal ability or general intelligence.

### Procedures

Qualified participants met me in Centennial Park in Nashville, TN for their pre-test session, which lasted approximately 2 hours. Upon arrival at the park, I guided participants to a park pavilion (top left of the light green park area on the map in [Figure 3](#)) and they completed the sit-down portion of the study at a picnic table.

### Computer-Based and Pencil-and-Paper Testing

This portion involved filling out two pencil-and-paper questionnaires: an *Information Questionnaire* designed to collect demographic information about the participants and the *Navigation and Map Use Questionnaire*. Next, I guided participants through the *Motor-Free Visual Perception Test* and the *Spelling Test*. Finally, participants finished two self-guided computer tests. The first was the *Mental Rotation Task (MRT)* and the second was the computer-based measure of map skill called the *Photo-Map Task (PMT)*. For both tests, participants sat at a picnic table using a laptop computer. Participants were verbally instructed, shown how to use

1.

### Instructions

In this task you will see a photograph at the top of the screen and a map on the bottom half of the screen.



3.

### Instructions

- Your job is to select the arrow that indicates where the photographer was standing when they took the picture.

– The photographer's position is indicated by the point of the arrow and the way the arrow is pointing indicates which direction the photographer was facing.



2.

### Instructions

On the map there will be 4 green arrows labeled with the numbers 1-4.

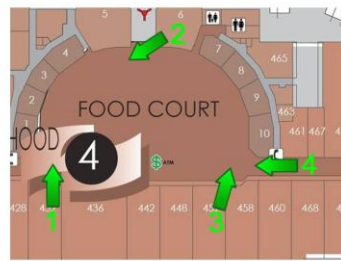

4.

### Instructions

Select the arrow that you think portrays the position of the photographer and press that number on the keyboard.

Once you have entered a number you will automatically proceed to the next trial.

This task is timed, so try not to waste time during the procedure, but remember accuracy is still very important.

5.

### Instructions

There are sections for this task and at the beginning of each section you will have time to view an overview map of the building/area that will be portrayed in the photos for that section.

You will have 30 seconds to study the map and acquaint yourself with what the map is showing and how it uses colors, shapes, etc. to provide information.

The trials in each section will use "zoomed in" versions from the overview maps and therefore the smaller maps use all of the same conventions as the overview map that they came from.

Figure 4. Photo-Map Task Instruction Slides

the written instructions and to start the testing programs, and were given the opportunity to ask questions.

For each trial of the Photo-Map task, participants had to look at a photo and determine where the photographer was standing while taking the photo (see Figure 4 for the instruction slides and an example of a trial). They had to select the one arrow on the map among 4 choices

that indicated where the photographer was standing and what direction he/she was facing. Participants then responded by pressing the corresponding number key (1-4) on the laptop keyboard. Photographs were taken at 3 separate locations in Nashville, TN (Opry Mills Mall, Belmont University, and the Opryland Hotel) with each location providing blocks of trials. The presentation order of the locations was randomized and the trials within each location block were presented randomly.

At the beginning of each block of trials, I showed participants an overview map of the entire location that included a map key. This allowed participants to familiarize themselves with the conventions of that particular map, which enabled them to better interpret the zoomed-in views used for individual trials. Zooming in was necessary for participants to see enough detail to distinguish the correct answer. Each map and each photograph on the computer screen was approximately 133mm across by 101mm high.

#### Real-World Navigation Testing

After completing the above sit-down portion of the testing, participants proceeded to the in-park testing, which included two measures of map use and navigation skill in Centennial Park. Both the *Real-World Map Task (RWMT)* and *Real-World Spatial Memory Tests (RWSM)* – adapted from Hegarty, Montello, Richardson, Ishikawa, & Lovelace, 2006) required participants to use a map to make distance estimates from their current location to distant landmarks that could not be seen from where they were standing. I told participants that they would be making distance estimates and took them to 1 of the 2 ends of a measured 100 yd. stretch of road within the park. Because the RWSM requires participants to make distance estimates from their memory of locations throughout the park, I showed them the distance from a stop sign to a curb and told them that the distance was equivalent to 100 yds, 300 feet, or roughly 91 meters. This was done specifically to help "calibrate" people to make estimates on the RWSM task more consistent and accurate. Participants were allowed to make their distance estimates using whatever scale they were most comfortable with but were advised not to use miles or kilometers (which were too big for most estimates). They were asked to make their distance estimates using the shortest and straightest line possible between their current location and the target landmark, regardless of obstacles. They also were told that they would need to point directly at the same target landmarks along the same, shortest straight line. I demonstrated this by showing the participant

the map (Figure 3) and using the park lake as an example of an obstacle that should be ignored. In the RWMT, participants had the map scale for making accurate distance estimates; however, *I did not point out the map scale, since one question was whether people would spontaneously use this map convention.*

So as not to make the tasks too simple, I did not show participants the map again until we arrived at the first trial location for the RWMT. Participants were not given specific information about their orientation in the environment at the start of the testing. However, I regularly referred to the sit-down testing location as a pavilion; the train and plane (near Location 1—see the satellite image of the park, Figure 5) were clearly visible from the pavilion and from the distance orientation area (where participants were shown the map prior to testing). Some participants, who began the real-world tasks at a different initial testing point (Location 3), could have used the Centennial Art Center (visible from that location) to orient themselves; to get to the starting point, they also walked along the lake with the Parthenon clearly visible across the lake. Thus, in each case, participants had visible landmarks that were labeled on the map as points of orientation.

After the orientation, we proceeded to the start point of the *Real-World Map Task (RWMT)*, which was always completed first for theoretical and practical reasons. I expected experience making distance estimates with the map while navigating to help participants better understand the scale of the park; it gave participants practice with the units of measurement they would use in the *Real-World Spatial Memory Test (RWSM)*, without diminishing the memory and spatial processing demands of the task. This order also limited the amount of walking necessary, a real concern since participants walked about 4 kilometers (2.5 miles) per testing session.

The starting location for the RWMT was either Location 1 or Location 3 (see Figure 5), from which participants completed the 3 trials in ascending/descending numerical order. Participants were randomly assigned to an order for Time 1 testing and received the opposite order for Time 2. At either location, I handed participants the park map in a random orientation and asked them to locate their position on the map. Participants could re-orient the map and were asked to use a dry erase marker to draw an “X” on the map where they thought they were standing. While the participant still had access to the map, I pointed out the position of a distant, unseen target landmark and he or she was asked to point to the landmark and estimate the distance to it from their current location (Heading and Distance Estimates). To make heading



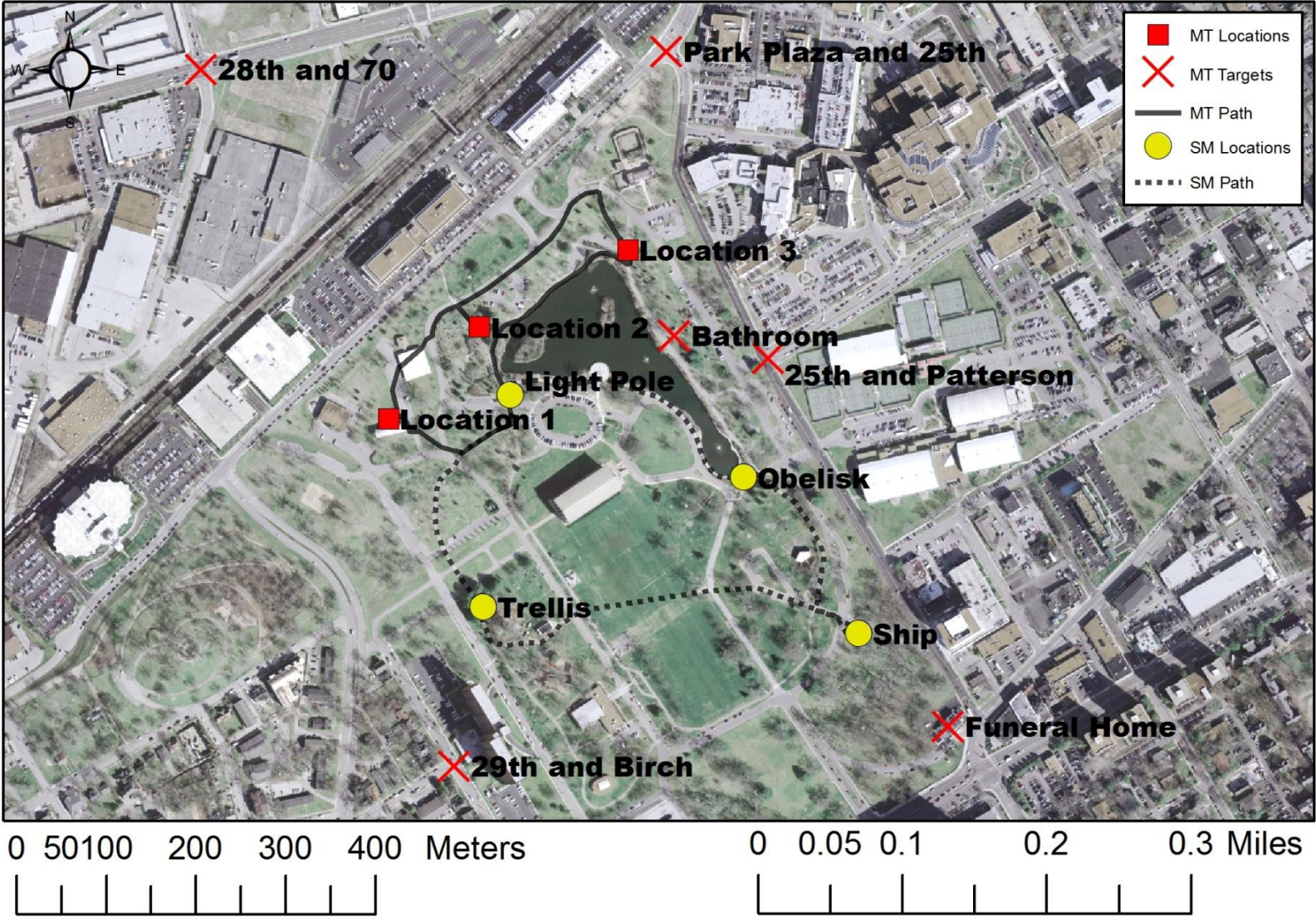

Figure 5. Real-World Map Task (MT) and Spatial Memory (SM) Paths and Landmarks on Satellite Image of Centennial Park

estimates, participants were handed a standard protractor/orienteering compass (described under Scoring and Calculations) with a large stationary arrow (the direction-of-travel arrow) printed on the front, and instructed to use this arrow as the pointer. After they had pointed with the compass, I took a reading from the North (red) compass needle in 5 degree increments to use later to determine their heading estimate. I then indicated a second target landmark and again asked participants to make heading and distance estimates. The set of target landmarks, indicated with an “X” in [Figure 5](#), were selected for each participant based on 4 possible sets of location/target pairings. Then I retrieved the map from participants and we proceeded to the next location and repeated the process. Participants were not given feedback on any answers; I did not have the answers to reduce the possibility of providing feedback or accidentally influencing participant answers. I gave participants a new, unmarked map at each of the test locations so that they were less likely to base their current placement estimate on where they thought they were at the previous location. In completing this task, participants made a total of 3 location estimates and 6 pairs of heading and distance estimates for 6 different target landmarks.

After completing the Real-World Map Task, participants were taken to the start point for the Real-World Spatial Memory Test. The start location was again determined randomly and participants started at either the Light Pole and went to the Obelisk, then the Ship, and ended at the Trellis, or started at the Trellis and ended at the Light Pole (see [Figure 5](#)). Participants again received the opposite orders at Time 1 and Time 2. On the way to the first location I told participants that they would follow me to 4 different locations that they would be asked to remember. We would stop at each location and they would have time to familiarize themselves with it before moving on to the next location. After visiting all 4 locations, we would arrive back at the first one and walk the route a second time. Participants were told that from each location they would have to point to and estimate the distance to the other 3 locations without using the map. They were reminded to make these estimates in the shortest/straightest line possible. I stressed that they would not be able to view the map again, that the task was done entirely based on what they could remember about the position of and distances between the landmarks, and that they would need to try to figure out the positions of the landmarks as we were making the first pass through them.

As we arrived at each location, I told participants the name of the landmark so that I could refer back to it. Participants were given as much time as they wanted to think about the

location and to think about the estimates. Although I did not specifically measure how long participants stopped, I estimate that in almost all cases, participants spent less than 15-20 seconds familiarizing themselves with each location before moving on to the next. As we were leaving each landmark, I repeated its name and went over the order in which we visited the landmarks (e.g., “We started at the Light Pole, then we went to the Obelisk, and now we’re leaving the Ship.”). After completing the first circuit through the locations, I took the participant back to the first location and asked him or her to point and make distance estimates to each of the other 3 locations (order was randomized). Again, participants were not given feedback about their answers and I did not have the correct answers.

Participants were not given a specific time limit to make their estimates for any parts of the RWMT or RWSM tasks. Only if participants were taking a long time (greater than about 2 minutes) did I ask them to make an estimate. Although I did not collect data regarding latencies, it was my impression that most of the people who took longer than 30 seconds tended to be confused about where they were and/or which way they were facing. Therefore, I would expect that trials with latencies beyond 30 seconds or less than about 10 seconds (i.e., "off-the-cuff" answers) would have relatively poor accuracies.

### Group Assignment and Training

After completing the in-park testing, participants were randomly assigned to the experimental or one of the two control conditions for video game training, with the constraint that groups were matched on number of males and females. As the study neared completion, I also adjusted assignments based on the age of participants. This became necessary due to differences in dropout among the groups. Participants were given all pertinent information about their assigned condition only. For the game playing conditions this included verbal and written instructions on installing/uninstalling and playing the assigned game, tips for getting the game to run smoothly if there were problems, instructions for retaining "save game" files, tips on playing, and instructions for filling out gaming logs used to track how much they played. I followed up with participants a couple of days later to ensure that they did not have trouble installing the game and were able to play it. If they had been unable to install the game I tried to talk them through steps to improve the game performance (which were also included with the installation instructions). Installing the games is similar to installing standard computer software programs,



so when installation problems did occur, it was typically due to an incompatible video card or another hardware compatibility issue and not the participant's computer skills.

Participants assigned to a game playing condition were told to complete 10 hours of game training over the course of a 2-4 week period prior to returning to the park for a post-test. Participants in the No-Play control condition were simply asked to return for a post-test session after the same delay. Participants not able to return within 28 days were dropped from the study (see Participants). A similar length of training was used by Feng et al. (2007), who found improvements in scores on basic level visual processing measures such as mental rotation. Because this study was intended to replicate part of that experiment while including additional measures focused on map- and memory-based wayfinding, a similar training window seemed appropriate.

Participants in the three training conditions were: 1) the experimental group, who played the game *Elder Scrolls IV – Oblivion* (ES); 2) a control group who played the game *Portal*; and 3) a *No Play* control group. Participants in the No-Play control condition did not engage in any study related activities during the training period. They simply were asked to return for the post-test at Time 2.

*Elder Scrolls IV: Oblivion*, the experimental training game, is a first-person role-playing game set in a very large VE. The main environment promotes map use by allowing the player to save significant amounts of time by identifying the best routes to specific destinations. At the outset of the game, players create a character that they will use for the remainder of the game. The main plot of the game revolves around one's character trying to thwart the efforts of a cult to open the gates to a hell-like realm called Oblivion. The plot is driven by the player completing quests assigned to him/her by non-player characters in the game. In pursuit of these quests and when not completing quests, a primary objective of the game is to develop character skills by collecting items to make the player more powerful and more skilled at particular aspects of combat and defense (e.g., magic or stealth). Other than characters' ability to perform magic and the existence of non-human characters, the main environment within the game generally is realistic looking with medieval-style buildings (i.e., large stone structures and small wooden houses) and technology (e.g., walking and horseback are the primary forms of transportation). [Figure 6](#) depicts two screenshots from the game's main environment. Truly unrealistic-looking environments are primarily found inside of "Oblivion," which the player visits in pursuit of



Images © 2006 Bethesda Softworks LLC

Figure 6. Screen Shots from *Elder Scrolls IV: Oblivion*

certain quests. All environments are highly detailed and are traversed by the character in the same realistic ways.

*Elder Scrolls* is known as an open-ended (or “sand box”) style game in which players generally can go where they want, when they want to, without advancing the plot of the game. Game play promotes map use because maps indicate the presence of enemies and dangerous areas and allow players to know where they have been, find the easiest routes to their destinations, and more quickly meet the game’s goals. The character view used throughout the game incorporates an auto-updating compass that depicts the current heading of the character (see [Figure 6](#)). An in-game map is accessible from the game menu (see [Figure 7](#)), which is where players manage the items they possess and view the progress of their characters. The in-game map keeps a static North-upward orientation with an auto-updating arrow indicating the position and heading of the character (lower left of [Figure 7](#)). This map also uses icons to indicate the position of specific locations within the game once the character has been instructed to find them and/or once they have been found. Participants also received and could use a 53cm x 45cm paper map of the main game world. The paper map gives a better overall view of the world, but does not include auto-updating features or icons marking locations that had been found (although the player could mark such locations manually).

Most quests or attempts to increase character skills involve instructions for finding one’s way to a specific location to retrieve an item. It would be possible to wander aimlessly; however, almost all activities include instructions to find and explore specific areas within the game world. Only by actively ignoring all objectives of the game could one play for a significant amount of time without needing to find specific areas within the VE. Therefore, I expected the navigation aspect of *Elder Scrolls* to provide repeated exposure to maps and the use of map conventions in the context of wayfinding, possibly allowing those skills to be transferred to similar tasks in the real world. For each session, participants were asked to record in their game logs the number of times they accessed the paper map and/or the in-game maps. These map counts indicated wide variation in map use—from 2 to 235 looks over the course of the study. Participants averaged approximately 8.3 ( $SD = 6.2$ ) looks at the map per hour of game play with a median of 7.6 looks per hour, a level of use in line with my own experience playing for 10 hours during the process of selecting the training games. Over 75% of the sample reported looking at the map at least 30 times during the training period.





Image © 2006 Bethesda Softworks LLC

Figure 7. Elder Scrolls IV: Oblivion In-Game Map

Besides the experimental training group who played Elder Scrolls, there were two control groups. The game used in the first control condition, *Portal*, is a first-person puzzle game that requires players to traverse a series of obstacle-laden rooms. The main game mechanic is the use of a “portal gun” that fires two types of linked portals onto walls, ceilings, and floors. Traveling through one portal allows the player to come out of the second portal, often in a different orientation. In this way, players move themselves and objects in the environment through the VE and overcome various obstacles. One important aspect of the portals is that they conserve the velocity of the character travelling through them. This game mechanic allows the character to be launched across gaps that cannot be jumped (see [Figure 8](#) for a diagram—Dammit, 2011).

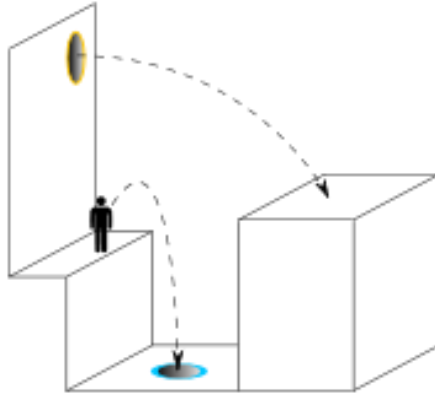

Figure 8. Diagram Illustrating the Use of Portals and Character Velocity to Traverse a Gap Too Wide to Be Jumped in the Game *Portal*.

The main plot of *Portal* starts with the protagonist, Chell, in her room at the fictional Aperture Science Computer-Aided Enrichment Center, an austere, high tech facility controlled by a female-voiced artificial intelligence computer known as GLaDOS. At first, GLaDOS appears helpful as she instructs Chell (controlled by the player) on how to proceed, but the computer becomes less stable and more evil as the plot progresses. The game culminates in a battle with GLaDOS.

The screenshot in [Figure 9](#) shows orange and blue Portals that the player has placed on the walls of a room. The player needs to move past or knock over a “turret” robot (the white oval objects with legs). Turrets are immobile, so the player can sneak up to the side or behind them; however, when the player approaches the red beams they emit, turrets target and shoot at the character. In this instance, the player is trying to use the portals to cross the room and come from behind the turret. Inside the orange portal, one sees the view coming out of the blue portal (e.g., the doorway visible on the right inside of the orange portal is actually the doorway that the character is facing at the center of the picture). The “two” turrets visible in this screen capture are actually opposite sides of the same turret.

In contrast to the "sandbox" nature of *Elder Scrolls*, all of the stages of *Portal* are isolated environments; once the player gets through, the plot does not return him or her to the same area. The game includes no maps and no way to revisit past levels, so there is little reason to believe the game would improve map-based or memory-based navigation skills. However, it does



Image © 2007 Valve Corporation.

Figure 9. Portal Screenshot

include a strong emphasis on using the visible spatial layout as a tool for achieving objectives. There is a real advantage to quickly and accurately understanding how the visual input of the environment will be affected as the character moves through the portals. For example, characters are rotated rapidly when portals are not spatially aligned (i.e., when one portal is placed *on a wall* in one room and the other linked portal ejects the player out *of the ceiling or floor* in an adjoining room). This can be very disorienting. As one progresses through the game, movements through Portals become more complicated (e.g., having to shoot new Portals in mid-air to chain together movements). Therefore, adjustments to the new orientation of the character must be made more quickly and accurately. I expected these aspects of the game play to have a positive effect on basic visual-spatial skills, particularly mental rotation ability. The actual game play experienced while playing either of the games used in this study can be viewed on internet video sites such as YouTube.

There were several reasons to include both game-play and no-game-play control groups. *Portal* contains very similar visual input (i.e., a first-person perspective) compared to *Elder Scrolls IV*. The game also contains a number of elements that might train lower-level spatial abilities (specifically, mental rotation), such as travelling through portals and needing to quickly re-orient to the environment. For this reason, playing both games potentially could have a positive impact on navigation at post-test. Including a control condition that so closely resembled the experimental condition enabled me to isolate the effect of the experimental manipulation (e.g., the use of maps) from the effect of general spatial experience in a VE, but also increased the possibility that both game-playing conditions would improve participants' skills. In the event that playing the two games did not have differential effects, the No-Play condition was intended to enable me to observe changes resulting from playing spatial video games in general versus merely experiencing the testing situation twice.

#### Post-Test Procedures

After the training period, all three groups returned for their post-test (T2) sessions at the park, which was identical to the pre-test (T1) except for counterbalancing of items across time points (described earlier) and the replacement of the Information Questionnaire with a set of Exit surveys. The exit surveys were administered to determine the fidelity of the training (e.g., did participants use websites or YouTube “walkthroughs” to help learn how to accomplish goals in the game); to assess participants' attitudes toward their assigned game; and to learn whether individuals used distinct strategies while playing the games (e.g., did they frequently use the maps). Training fidelity was also assessed by collecting the gaming logs participants were given at pre-test and by transferring “game save files” from participants' computers. Participants were asked to accumulate these over the course of the study by saving a new file to their computer after each playing session as an electronic record of their progress. Save files allowed some verification of the game journals and provided proof that participants were playing the assigned game. (An in-game clock associated with *Elder Scrolls* tracks the number of hours played, but it pauses each time a participant looks at the game menu—the location of the map and spell/item lists. More important, if a participant’s character dies, the clock reverts back to the last save file, so it is not a very accurate reflection of the amount of time played.)

Of the 40 participants in the two game-play conditions, 35 returned game save files, all consistent with having played the assigned game. Most instances of people failing to return save files were due to quickly uninstalling the game when they were finished playing (making the files unrecoverable). Of the 40 participants, 36 returned with completed game logs. The 4 who did not claimed that the logs were lost or accidentally left at home (these were never returned). Only one retained participant did not return either a log or save files. I decided to retain all of these participants because their answers to the Exit Surveys were consistent with having played the game. I also engaged all participants in discussions about the game during the testing sessions and was convinced they had played a significant amount; the incentives for completing the study were minor compared to the time commitment, so retained participants had little motivation to be dishonest (most who were non-compliant with the game play requirement had dropped out of the study by this point). Fidelity of training contributes to the real-world effectiveness of any intervention, but it is typical to find a range of strictness of compliance. Removing participants who may have been non-compliant would overestimate the effectiveness of a home-based, video game training approach in a non-playing population.

### Scoring and Calculations

There were a number of options for scoring the real-world navigation tests and extracting useful data from the raw data collected during testing. Geocoding the data added to the complexity of scoring, but the resulting data can be used very flexibly. The following section documents these steps. Trials in which participants were estimating their current location (i.e., *Placement Estimate* trials present in the RWMT only) were scored by making a copy of the marked map after the testing session and geocoding the location using a grid overlay with known latitude/longitude and distance properties. The Placement Estimate scores were then created by calculating the distance of that geocoded location from the actual correct location. Because the resulting scores are error scores, smaller scores indicate better performance and they were heavily skewed. The data was transformed by adding a constant of 1 and doing a  $\log_{10}$  transformation; equation:  $\log_{10}(\text{estimate error}+1)$ . By geocoding this data and data from the distance/heading estimates, it was possible to plot data from this study using GIS technology. All satellite image plots for this study were created using ArcGIS ver. 9 (ESRI Inc., 2009) and image data furnished by Vanderbilt University's GIS Services.



Both the Real-World Map and Spatial Memory tests required participants to make distance estimates from their current location to a target landmark. Instead of using error as the main outcome variable for these distance estimates, I used Hegarty et al.'s (2002) method, computing correlations between each participant's estimates and the actual distances for the trials. This method ignores the systematic error involved in participants' representation of the length of a unit of measure; the correlations essentially represent participants' skill based on how well they are able to scale their judgment on one trial relative to the others. I normalized these negatively-skewed data by reverse scoring them and applying a natural log transformation; equation:  $\ln(1.01 - \text{distance } r)$ . Consequently, smaller scores reflect better performance.

On each trial on which participants made distance estimates, they were also asked to indicate the heading they would take to the landmarks using a standard protractor (or orienteering) compass (*Heading Estimates*). The position of the rotating housing that surrounds the compass needle and has the scale on it (i.e., the bezel) was fixed for use in this study so that  $0^\circ$  was always aligned with the direction-of-travel arrow on the front of the compass. This ensured that the compass readings would correspond systematically to 0 degrees (i.e., North). I read participant estimates of the heading of distant landmarks from the compass bezel (in 5 degree increments), based on the position of the North (red) compass needle. As an example, a participant pointing due North would have the red needle and the direction-of-travel arrow in line with  $0^\circ$  on the bezel. If that participant then turned  $20^\circ$  in a clockwise direction (i.e., turned to a heading of  $20^\circ$  in relation to North), the red compass needle would remain pointed North (since it is floating within the compass housing) and the bezel and direction-of-travel arrow would rotate in relation to it. The red needle would then be pointed at  $340^\circ$  on the bezel (which is what I would record). This raw number must be subtracted from  $360^\circ$  in order to yield the heading of the direction-of-travel arrow in relation to North ( $360 - 340 = 20^\circ$ ). See [Figure 10](#) for an illustration of this example. According to the National Oceanic and Atmospheric Administration (2011), the declination (i.e., difference between magnetic and “true” North) in the area of Centennial Park (zip code = 37201) varied from  $3.03^\circ$  West to  $3.15^\circ$  West across the study dates. Due to the small size of the difference between magnetic and “true” north at this location, declination was ignored for all heading calculations.

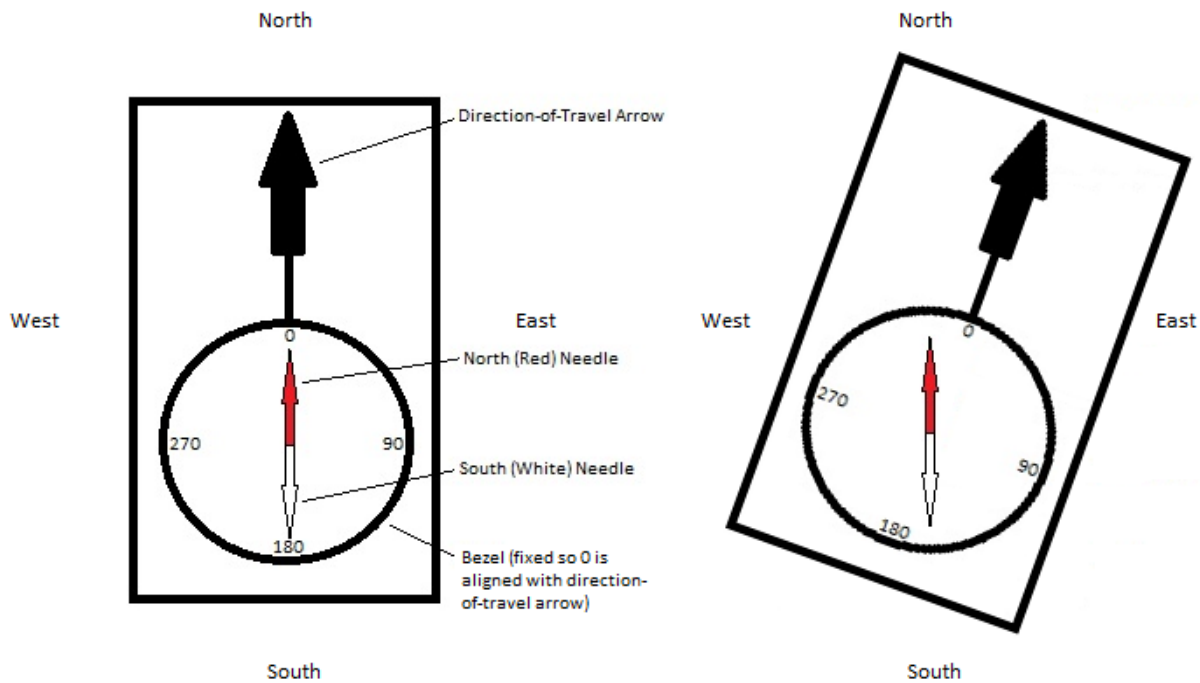

Figure 10. Compass Diagram and Heading Estimate Scoring Example

All heading estimates were scored as error from the correct answer; these error scores clustered around 0 and were extremely skewed. To normalize the data, a constant was added to all data points and a  $\text{Log}_{10}$  transformation was used; equation:  $\log_{10}(\text{estimate}+1)$ . Consequently, the units for the averages of these measures are undefined and smaller numbers indicate better performance.

Average scores for the RWMT and RWSM were calculated by taking the z-score of the average from each of the 3 trial types (location, distance, and heading) and computing an average z-score for each participant on each of the two tests. Finally, the scores from the RWMT and RWSM were combined to create an overall Real-World Navigation score (RW Nav). All of these overall scores are similar to the rest of the data from the spatial memory and map tests in that higher performing participants have lower scores.

## CHAPTER VI

### RESULTS

Unless otherwise noted, all analyses involving only data from Time 1 used the full sample of data ( $N = 78$ ). All analyses involving T2 were based on the final sample ( $N = 60$ ; 3 groups of 20—see Participants). I used the full sample for T1 because it likely is more representative of the overall population and provides additional statistical power. Because participants were not assigned to group until after T1, group distinctions were ignored for T1 analyses unless noted. All statistical tests used an alpha level of .05 and actual  $p$ -values are reported where the values were greater than .001.

#### Sample Comparisons

I compared the participant samples from Study 1 and Study 2 under the assumption that the former group may be a broader and more representative sample of the population. In both studies, participants were required to own a computer and in Study 2, the computer had to be relatively modern, so I expected both groups to have higher than average socio-economic status. Some of the demographic questions (e.g., about family income) were reworded for Study 2, given the number of student participants expected (e.g., a college student's "personal income" often will underestimate his or her relative SES), and many could not accurately estimate their parents' yearly income. Therefore, the samples are not directly comparable using participant-reported SES. I used zip codes (of permanent residence) and publicly available data from the 2000 census to gather some information related to SES and other demographic variables. The samples were marginally different on per capita average income (Study 1  $M = \$27,973$ ,  $SD = \$13,552$ ; Study 2  $M = \$24,856$ ,  $SD = \$11,078$ ;  $t(666) = 1.85$ ;  $p = .064$ ;  $d = .23$ ) and median income per household ( $M = \$51,738$ ,  $SD = \$22,230$ ;  $M = \$46,498$ ,  $SD = \$19,495$ ;  $t(666) = 1.89$ ;  $p = .059$ ;  $d = .24$ ). There were no marginal differences in participants across studies in other potentially relevant variables, including percent of the population living in rural areas and average travel time to work (possible indicators of navigation experience).

## Measure Development

The Navigation and Map Use Questionnaire and the Photo-Map Task were included in this study primarily as a means of better establishing valid and efficient tests of navigation that could be administered consistently. This section of the paper details the reliability and validity of the measures, some of the steps I took in developing them, and possible future steps for improvement. I report specific real-world data in an effort to make the results of my testing more easily comparable to the results of other research projects using similar methods in different testing locations.

### Navigation and Map Use Questionnaire Reliability

Chronbach's alpha coefficients for Factors 2 and 3 in Study 1 (see [Table 3](#)) and in Study 2 at T1 were similar. The reliability for Factor 4 was significantly lower in Study 2 (T1  $\alpha = .34$ ), supporting my initial concerns regarding that scale in Study 1 and providing further justification for my decision not to retain it.

Additional assessments of questionnaire reliability across studies were complicated by the use of 5- and 7-item Likert scales in Study 1, and the exclusion of game players from Study 2. Nonetheless, there are indications that the questionnaire factors behave similarly across the two independent samples. For example, there is a similar pattern of effect sizes for the sex differences found on Factors 2 and 3 in Study 1 ( $d = .47$  and  $.72$ , respectively) and Study 2 ( $d = .37$  and  $.61$ ).

### Navigation and Map Use Questionnaire Validity

Validity results are presented in [Table 7](#). For Study 2, correlations between Factor 2 from the questionnaire (Navigation Skill) and average performance scores on the real-world navigation tests are significant. The correlations are negative because the real-world navigation scores are error scores (i.e., lower scores correspond to better performance). The magnitude of the correlations are similar to those found in Hegarty et al. (2002) between the SBSODS and scores on an indoor spatial memory test ( $-.43$  for heading estimates and  $.36$  for distance estimates; I chose to transform my distance estimates, which reversed the sign of my correlation in relation to theirs).

Table 7. Study 2 Questionnaire Correlations

Questionnaire Variables		Photo-Map	RWMT Average	RWMT - Distance Est. <i>r</i>	RWMT - Heading Est.	RWMT - Location Est.	RWSM Average	RWSM Distance Est. <i>r</i>	RWSM - Heading Est.	RW Nav. - RWMT & RWSM	Mental Rotation	MVPT	Spelling
No Control ( <i>df</i> =78)	Factor 2 (Navigation)	<i>r</i> <b>.274</b> <i>p</i> <b>.02</b>	<b>-.370</b>	-.222 .05	<b>-.342</b> .00	<b>-.312</b> .01	<b>-.297</b> .01	-.203 .07	<b>-.415</b> .00	<b>-.410</b> .00	<b>-.300</b> .01	.207 .07	.093 .42
	Factor 3 (Adv Map Instruction)	<i>r</i> .194 <i>p</i> .09	<b>-.372</b> .00	<b>-.469</b> .00	-.105 .36	-.156 .17	-.064 .58	.030 .79	.018 .88	<b>-.256</b> .02	-.136 .24	.183 .11	<b>-.223</b> .05
	Factors 2 and 3 (Avg. of all items)	<i>r</i> <b>.313</b> <i>p</i> <b>.01</b>	<b>-.463</b> .00	<b>-.370</b> .00	<b>-.338</b> .00	<b>-.332</b> .00	<b>-.283</b> .01	-.166 .15	<b>-.356</b> .00	<b>-.455</b> .00	<b>-.313</b> .01	<b>.250</b> .03	-.002 .98
	Mean of SBSODS Items	<i>r</i> <b>.296</b> <i>p</i> <b>.00</b>	<b>-.381</b> .00	<b>-.233</b> .04	<b>-.341</b> .00	<b>-.326</b> .00	<b>-.293</b> .01	<b>-.200</b> .08	<b>-.377</b> .00	<b>-.414</b> .00	<b>-.338</b> .00	<b>.263</b> .02	.035 .76
Partial Corr. - Spelling, MRT, & MVPT ( <i>df</i> =73)	Factor 2 (Navigation)	<i>r</i> .164 <i>p</i> .22	<b>-.314</b> .01	-.178 .13	<b>-.268</b> .02	<b>-.280</b> .02	<b>-.255</b> .03	-.148 .21	<b>-.363</b> .00	<b>-.355</b> .00			
	Factor 3 (Adv Map Instruction)	<i>r</i> .050 <i>p</i> .71	<b>-.354</b> .00	<b>-.449</b> .00	-.097 .41	-.141 .23	-.019 .87	.077 .51	.074 .53	-.218 .06			
	Factors 2 and 3 (Avg. of all items)	<i>r</i> .166 <i>p</i> .22	<b>-.410</b> .00	<b>-.328</b> .00	<b>-.271</b> .02	<b>-.299</b> .01	<b>-.231</b> .05	-.100 .39	<b>-.289</b> .01	<b>-.394</b> .00			
	Mean of SBSODS Items	<i>r</i> .162 <i>p</i> .23	<b>-.315</b> .01	-.176 .13	<b>-.264</b> .02	<b>-.292</b> .01	<b>-.240</b> .04	-.134 .25	<b>-.306</b> .01	<b>-.346</b> .00			

Real-World Navigation Tests and Mental Rotation: lower score = better performance

The correlation between Factor 3 (Advanced Map Instruction) and real-world map task average score is driven primarily by the relationship between advanced instruction and distance estimates (those on which participants did most poorly). Thus, advanced map instruction (e.g., participation in scouts or orienteering activities) appears to be particularly important for making distance estimates using a map, but may not be needed to identify one's location on a map or determine the proper heading to a distant landmark. This suggests that the primary benefit of exposure to maps may be learning their conventions; for example, using the map scale to determine distances and interpreting symbols on the map key. However, in Study 2, the relatively simple map, structured park setting, and basic test of ability simply may not have required enough advanced map skills (e.g., interpretation of topography, using transit lines and triangulation for identifying location, etc.) for these prior training experiences to play a more robust role in location and heading estimates.

Overall, the navigation factors from the Navigation and Map Use Questionnaire (Factors 2 and 3) have good reliability in both Study 1 and Study 2. Validity data from Study 2 shows correlations that are similar in magnitude to that observed in the development of the SBSODS (a very similar self-report measure) and the two factors show differentiation based on what they were expected to measure (e.g., the advanced map training factor is related to average scores on the RWMT, but not the RWSM test which did not require the use of a map). Likewise, using the two factors in combination with one another appears to yield a good general measure of overall skill in navigating large-scale environments.

### Photo-Map Task Reliability

The original Photo-Map Task was developed for children (Liben et al., 2002). One of the challenges of modifying this measure for use with adults was finding items of an appropriate range of difficulty. Although participants' scores ( $M = 58\%$  (chance = 25%),  $SD = 13\%$ , range = 28% to 87%) indicated a reasonable range of difficulty across items, the final sample of participants struggled with this test more than my pilot sample of mostly Vanderbilt graduate students. I attempted to refine the test by removing 10 items with poor item-total correlations ( $r < .10$ ). Mean group performance on each of these items was near chance; removing them increased the average performance of the group and reduced a slight floor effect. The removal of an additional 5 items with relatively poor item-total correlations resulted in a 15-item scale with

a near-normal distribution of scores with appropriate variability, item-total correlations ranging from .18 to .39, and a coefficient alpha of .67.

From participant feedback and my own experience completing the test, it seems likely that these problems with internal consistency stem from differences in task demands for individual items, which rely more or less heavily on certain basic skills that make for efficient map use. For example, compared to the other locations, the mall provided many more uniquely identifying pieces of information to use in figuring out the relative location of elements in the depicted environment (the photo) and on the map; for instance, store names were clearly labeled on the map. This combination may favor individuals who have more experience with landmark-based strategies, whereas the environments/maps from other locations may be solved more optimally using other sources of information, such as the geometry of the depicted space.

Skill in using maps can hardly be a unitary construct. There are individual differences in component skills such as mental rotation or the ability to create mental representations of large scale spaces (Hegarty & Waller, 2006). In the future, more trials and participants will be necessary to determine whether the items in the Photo-Map test would separate into meaningful sub-groups based on picture content and the various underlying skills elicited. Some items may require close attention to heading information (e.g., determining the angle at which the photographer stood in relation to a pictured building) to differentiate the correct answer from distractors. For other items, the presence or absence of certain landmarks or features of the terrain may be more informative. Still others may require a high degree of mental rotation in order to compare possible answers. In the study reported here, increasing the internal consistency of this task when it was not measuring a basic construct would sacrifice the validity of the test as a *general* measure of map-based navigation ability.

#### Photo-Map Task Validity

Scores on the 15-item PMT are significantly correlated with scores on the Real-World Map Task, overall navigation scores from the real-world testing, and both the Mental Rotation and Motor-Free Visual Perception Tests (see [Table 8](#)). They were not significantly correlated with tests from the Real-World Spatial-Memory Task or Factor 2 from the questionnaire, but there was a trend for both. After controlling for the effect of the spatial tests (the Motor Free Visual Perception Test and Mental Rotation Test) and spelling, the correlation between the

Photo-Map and Real-World Map Tasks remained significant. This pattern of correlations indicates that lower-level spatial skills such as mental rotation, spatial perception, and spatial visualization do not mediate the relationship.

As seen in Table 8, the full 30-item Photo-Map Test shows a similar pattern of correlations and a trend toward *higher* correlations with all of the real-world tests and questionnaire scales. In fact, the only correlation that is lower for the 30-item test is with the spelling test, which would not be expected to relate to the PMT. This pattern provides a clear indication of the tradeoff between a desire to increase internal consistency and an interest in retaining a valid measure of a complex skill.

The above analyses prompted me to compare the test-retest reliability of the 15- and 30-item versions of the PMT to determine the most useful form, even though Study 2 is not a true test-retest situation. Any effects of video game play and of simply participating in other parts of the study would result in underestimating actual test-retest reliability, but these experiences should have a similar effect on both shortened and full versions. Despite the 15-item scale

Table 8. Photo-Map Task Correlations

		Questionnaire Factor Data				Navigation Variables			Control Variables		
		F2 – Nav	F3 - Adv. Map Inst.	F2 & F3 Comb	SBSO DS	RW MT Avg	RW SM Avg	RW Nav	Spelling	MRT	MVPT
15-Item PMT – (N = 78)	<i>r</i> <i>p</i>	.218 .06	.121 .29	<b>.236</b> <b>.04</b>	<b>.245</b> <b>.03</b>	<b>-.343</b> <b>.00</b>	-.214 .06	<b>-.340</b> <b>.00</b>	.159 .17	<b>-.300</b> <b>.01</b>	<b>.371</b> <b>.00</b>
15-Item PMT - Partial Corr. Spelling/MRT/MVPT (N = 73)	<i>r</i> <i>p</i>	.098 .40	.103 .38	.125 .28	.118 .31	<b>-.269</b> <b>.02</b>	-.178 .13	<b>-.277</b> <b>.02</b>			
30-Item PMT – (N = 74)	<i>r</i> <i>p</i>	<b>.274</b> <b>.02</b>	.194 .09	<b>.313</b> <b>.01</b>	<b>.296</b> <b>.01</b>	<b>-.402</b> <b>.00</b>	<b>-.226</b> <b>.05</b>	<b>-.381</b> <b>.00</b>	.082 .48	<b>-.385</b> <b>.00</b>	<b>.373</b> <b>.00</b>
30-Item PMT – Partial Corr. Spelling/MRT/MVPT (N = 73)	<i>r</i> <i>p</i>	.151 .20	.166 .16	.132 .26	.196 .09	<b>-.325</b> <b>.00</b>	-.164 .16	<b>-.300</b> <b>.009</b>			

Real-World Navigation Tests and Mental Rotation Task: lower score = better performance



having better internal consistency, the 30-item scale had better test-retest reliability ( $r = .561, p < .001$  vs.  $r = .707, p < .001$ , respectively). In consideration of the full range of validity and reliability information, I decided to retain the full 30-item measure. All statistics about the PMT reported in other sections of this paper are based on that scale.

I initially was concerned that mental rotation would mediate the relationship between the computerized Photo-Map Task and the Real-World Map Task. The PMT on a fixed computer monitor requires participants to mentally compare 4 possible arrows pointing in different directions on a map, without being able to physically rotate the map. Research shows that when people are unable to create an alignment between a map and the space they are navigating, their performance on map tests decreases dramatically (Levine, Marchon, & Hanley, 1984). Thus, the Photo-Map Task repeatedly violates most people's instinct to *physically* create this alignment and required participants to make the alignment mentally (i.e., use mental rotation) or use other strategies. Although mental rotation scores did not mediate the relationship between scores on the Photo-Map and Real-World Map Tasks, these misalignments remain a possible reason for the difficulty of the test. Since future attempts to develop this measure will also focus on generating a larger pool of easier/intermediate items, I could manipulate the level of misalignment in an attempt to produce trials that are easier to solve. In developing future versions of the PMT, I will also focus on creating a broader range of item types from more locations. More variety in trial type, location, and difficulty should help the reliability and validity of the overall test.

Thus, the PMT needs further development to be a useful measure of map-based navigation skills, although it does appear to be a good measure of general spatial ability. Development efforts will be directed at identifying a broader range of item difficulties. To increase its utility as a measure of map-use skills specifically, larger data sets will be required to identify groups of items which are more highly related to real-world test scores.

### Real-World Spatial Memory and Map Tests

Table 9 contains descriptive statistics on the raw data from the real-world navigational testing. Because the data reported in the remainder of this study was transformed, making it more difficult to interpret, I report raw data here to help clarify the actual performance of the participants and the difficulty of the tasks. For example, in the spatial memory task, the mean of the distances that participants estimated was 323m and the longest distance they estimated was

470m. Considering the actual length of the estimates participants were asked to make, the median error of 120m for those trials was quite large. In the map task, the two most distant positions that participants visited were about 330m apart, The entire map depicted an area 1019m x 1019m, and the mean of the distances they estimated was 431m (longest distance = 680m). For these trials, participants were equipped with a map that included a scale that was expected to make the distance estimates easier. Despite having the map, the median error for distance estimates was a whopping 147m.

Table 9. Study 2 - Time 1: Raw Data from Real-World Navigation Testing

	Spatial Memory		Map Task		
	Heading - error in degrees	Distance - error in meters	Placement- error in meters	Heading - error in degrees	Distance - error in meters
Mean	17.38	146.42	14.03	30.77	211.58
Std. Deviation	7.94	94.48	17.16	20.76	170.73
25	11.10	71.70	3.68	14.75	101.98
Percentile 50	15.17	120.36	7.18	22.08	147.02
75	22.85	202.53	18.02	39.77	276.28
<hr/> <i>N</i> = 78 <hr/>					

Figure 11, shows the Placement estimates (i.e., estimates of their location) of all 78 participants at pre-test for each of the 3 Placement trials. As illustrated by Table 9 and in Figure 11, as a group, participants appeared to do reasonably well at finding their current location on the map. Participants had the most difficulty on Map Task trials originating from Location 3 and the least difficulty with Location 1 trials (for Placement, Heading, and Distance estimates).

Figure 12 shows 2 trials geocoded from the Heading and Distance estimates that participants made from Location 2 of the Map Task; they were pointing to the Bathroom and Funeral Home target locations. (Latitude and longitude were calculated for each data point from the combination of a participant's heading and distance estimates in relation to the known location where the participant was standing.) The target landmarks for the Map Task, on

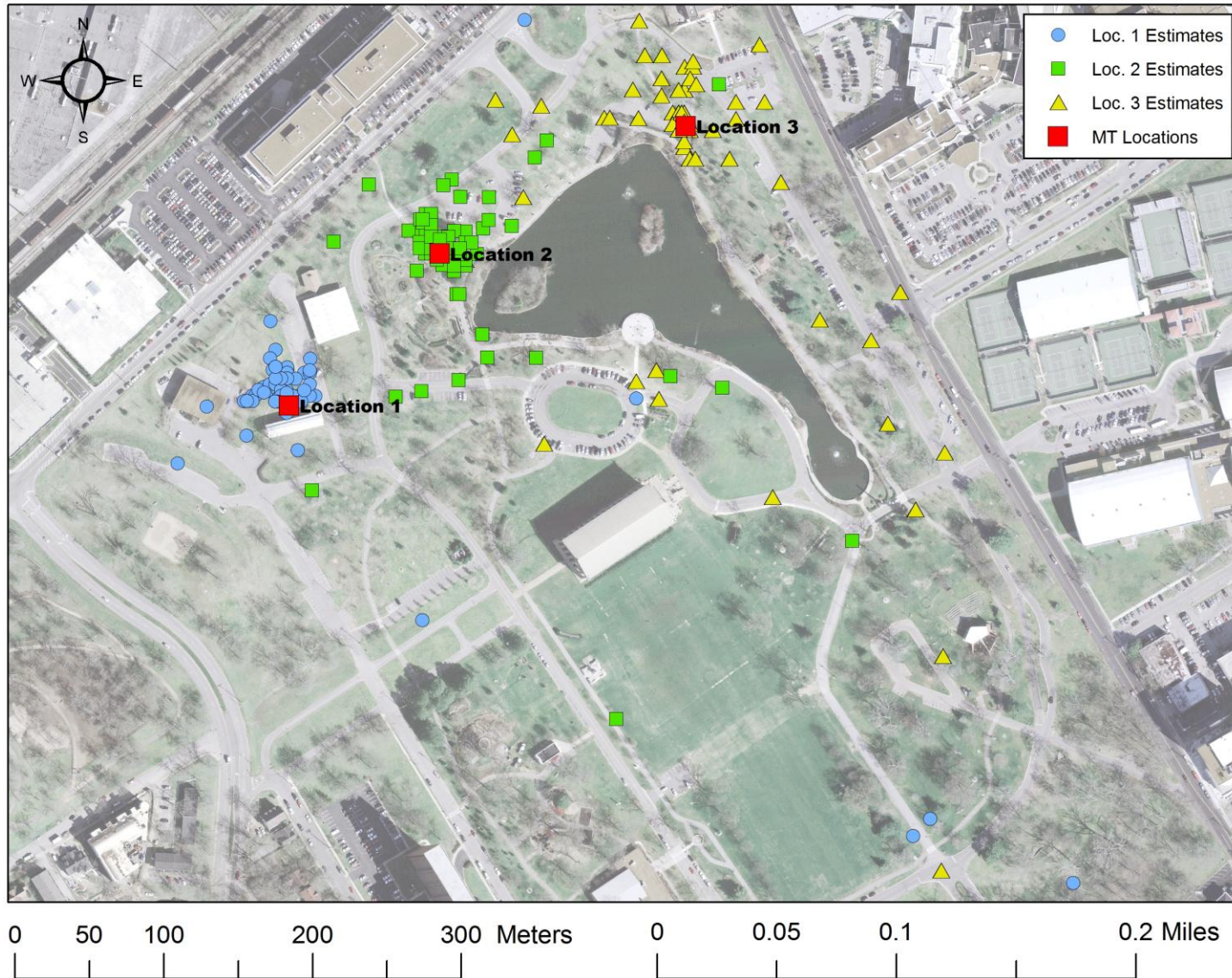

Figure 11. Real-World Map Test—Placement Estimates from All 3 Pre-Test Trials



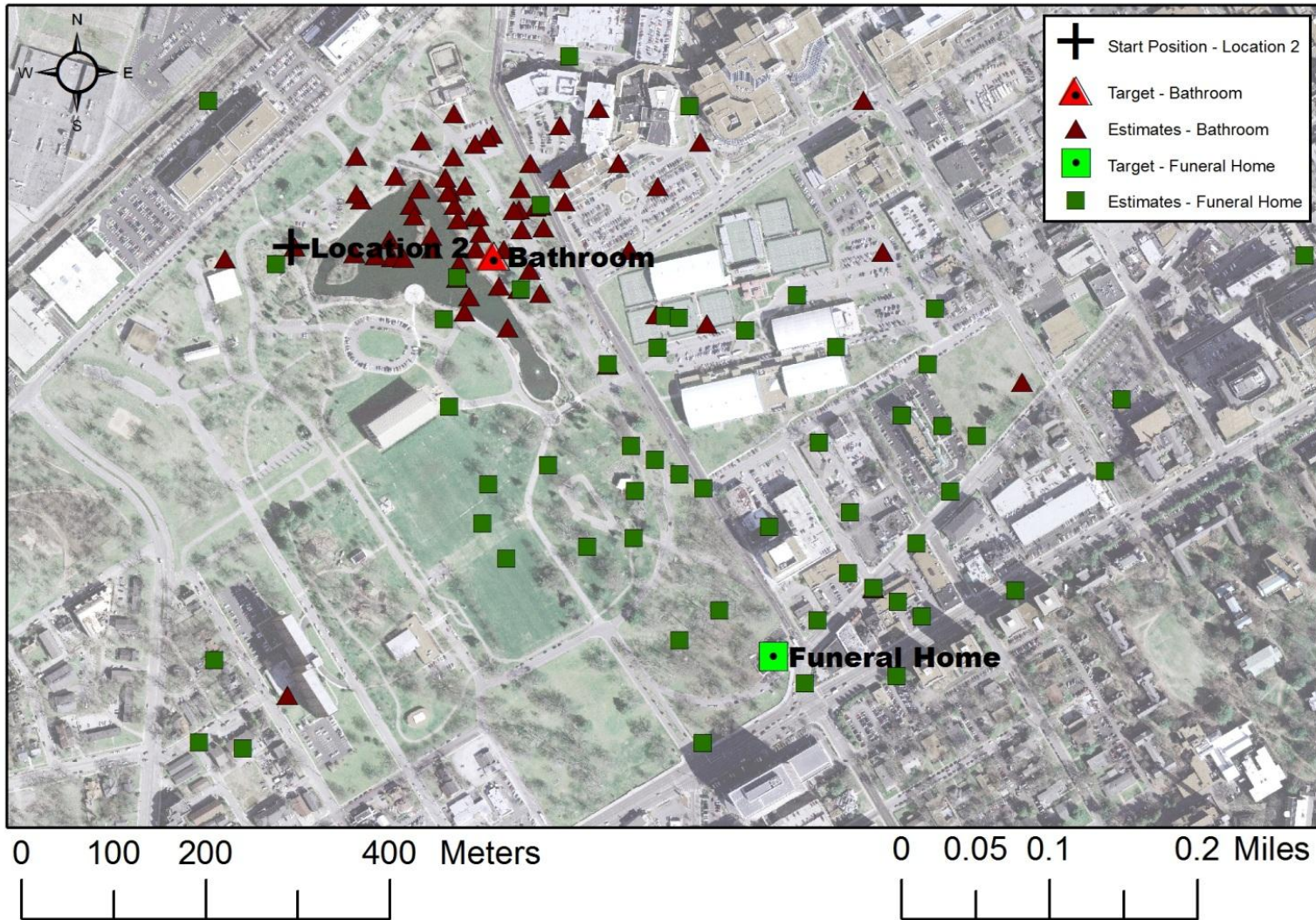

Figure 12. Real-World Map Test—Heading/Distance Estimate Plots from 2 Pre-Test Trials  
 (Standing at Location 2 and Pointing to the Bathroom and Funeral Home)

average, were farther from each other than the distances between landmarks estimated in the Spatial Memory task. This difference may explain why the mean error tended to be higher for the Map Task, since more error would be expected to accumulate when estimating longer distances. For instance, in [Figure 12](#), the distance between the start point and the Bathroom target location on the MT is more similar to the typical between-landmark distance during SM trials; perhaps for this reason, points to the Bathroom were more accurate than those to the Funeral Home. However, the amount of error for Distance estimates on the Map Task is quite surprising considering that participants were relatively good at estimating their own location (over 75% were within 20m of the actual location) and that a distance scale was given on the map. If participants were able to accurately identify their current position and the target landmark that was indicated on the map, a simple measurement and comparison to the map scale printed at the bottom of the map should have allowed people to accurately calculate the distance to those landmarks, even without being able to make an accurate Heading estimate. That said, quite a few participants did not appear to look for or use the scale key at all, and it seems likely that even many of those who did were unable to use it properly.

Since a scale key is one of the elements appearing on almost every map created, the number of participants who overlooked it was unexpected and probably explains some of the trouble participants had with the Map Task Distance estimates. Possibly, showing the measured distance (from curb to stop sign) at the beginning of the real-world testing may have interfered with the strategies of participants who otherwise may have looked for the scale on the map. Although this is a legitimate concern, their failure still demonstrates a lack of knowledge about maps. The scale was clearly available when I pointed out the target locations on the map and asked them to make their estimates. Likewise, if participants thought they were supposed to make the judgments based on the measured distance at the start of testing, they could have found that location on the map and used the measured distance like a scale to create a fairly accurate distance estimate.

[Figure 13](#) shows the data from a Real-World Spatial Memory pre-test trial. Participants were standing at the Light Pole and pointing to the Obelisk. This figure demonstrates the spread of data typical of a Spatial Memory trial and some of the analytical features of Geographic Information Systems (GIS) for this type of data. The plot includes a spider diagram connecting each point to the location of origin, which clearly depicts the spread of the Heading data. A plot



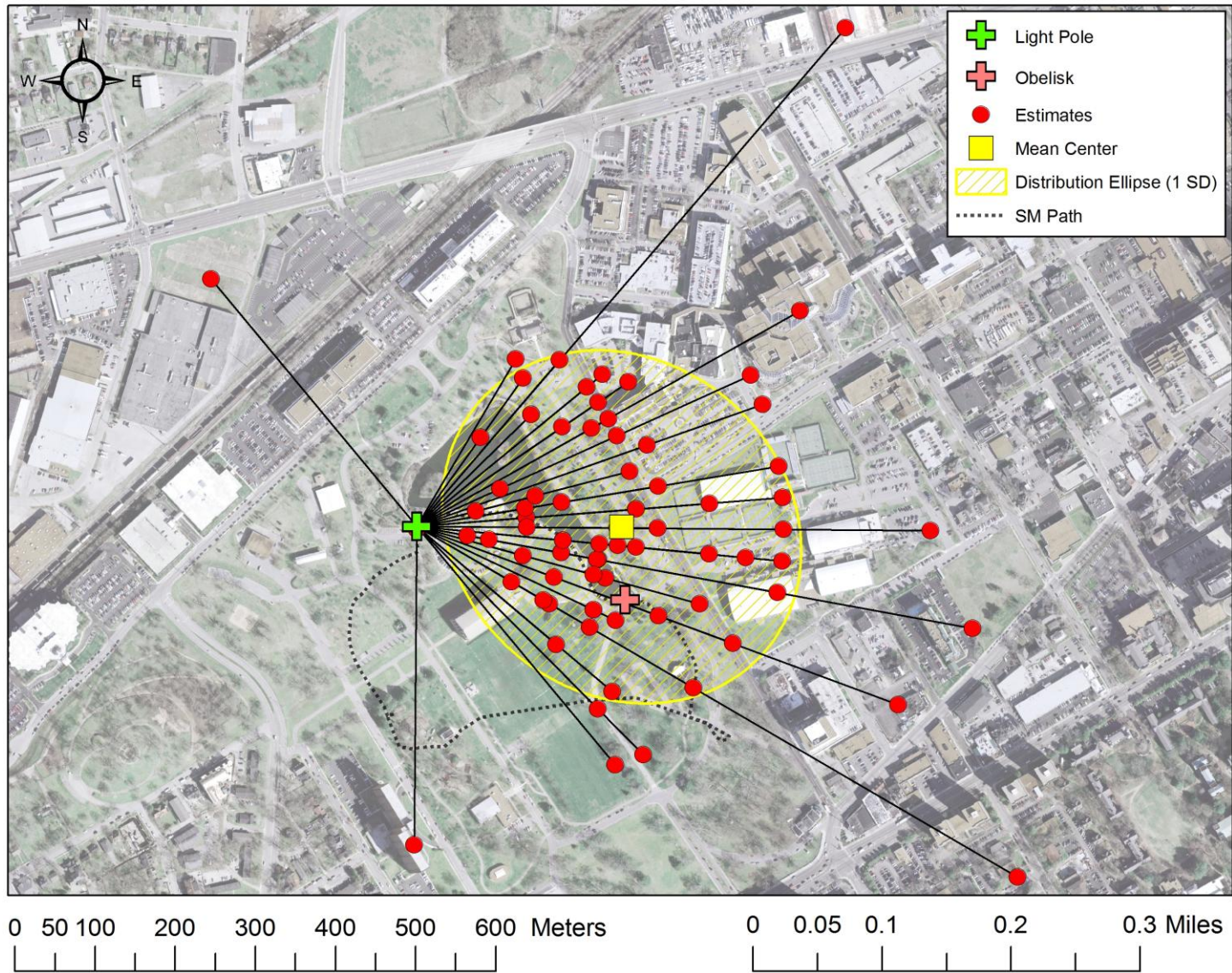

Figure 13. Real-World Spatial Memory Test—Heading/Distance Estimates from the Light Pole to the Obelisk

of the mean center of all of the data points illuminates systematic shifts in estimates at the group level. For example, the estimated mean distances appear to be fairly comparable to the actual distance, but estimates were systematically shifted to the left of the actual location of the target landmark (by approximately 15 degrees even after accounting for declination). GIS also allows one to chart other properties of the distribution of the data; for example, in Figure 13, I have drawn an ellipse encompassing all points that make up the first standard deviation from the mean of the data. These plots and the information in Table 9 demonstrate the difficulty that many participants had in completing these navigation tests and illustrate that navigation, even with maps, is not a trivial problem for many people.

Table 10 shows correlations of scores from the *Real-World Navigation Test* with other study variables. Scores on the *Real-World Map Test* were correlated with the majority of the other navigation and spatial variables. In contrast, scores on the *Real-World Spatial Memory Test* were not correlated with Factor 3 (Advanced Map Instruction) or scores on the Motor-Free Visual Perception Test and were only marginally correlated with the Photo-Map Task. Fisher r-z transformation was used to compute 95% confidence intervals for these correlations. The correlations between Factor 3 and scores on the real-world *map* test,  $r(95\% \text{ CI}) = -.372$  (-.549 to -.163), and *spatial memory* test,  $r(95\% \text{ CI}) = -.064$  (-.283 to .161), were significantly different from one another. These results provide support for my hypothesis that the skills required to complete the real-world map and spatial memory tasks are different, and are an

Table 10. Real-World Navigation Test Correlations

		Photo-Map	RW MT Avg	RW SM Avg	F2 - Nav	F3 - Adv. Map Inst.	F2 & F3 Comb.	SB SODS	MRT	MVPT	Spelling
RWMT	<i>r</i>	<b>-.402</b>			<b>-.370</b>	<b>-.372</b>	<b>-.463</b>	<b>-.381</b>	<b>.246</b>	<b>-.231</b>	.008
	<i>p</i>	<b>.00</b>			<b>.00</b>	<b>.00</b>	<b>.00</b>	<b>.00</b>	<b>.03</b>	<b>.04</b>	.94
RWSM	<i>r</i>	-.226	<b>.298</b>		<b>-.297</b>	-.064	<b>-.283</b>	<b>-.293</b>	<b>.234</b>	-.125	.081
	<i>p</i>	.05	<b>.01</b>		<b>.01</b>	.58	<b>.01</b>	<b>.01</b>	<b>.04</b>	.27	.48
RW Nav	<i>r</i>	<b>-.381</b>	<b>.772</b>	<b>.837</b>	<b>-.410</b>	<b>-.256</b>	<b>-.455</b>	<b>-.414</b>	<b>.297</b>	-.216	.058
	<i>p</i>	<b>.00</b>	<b>.00</b>	<b>.00</b>	<b>.00</b>	<b>.02</b>	<b>.00</b>	<b>.00</b>	<b>.01</b>	.06	.61

*N* = 78; Real-World Navigation Tests and Mental Rotation: lower score = better performance

indication that Factor 3 is measuring skills specific to map-based navigation but not to memory-based navigation.

Variants of both of the real-world navigation tests from the current study have been used previously in navigation research. Both of these tasks have good face validity and, judging by study data from the sit-down testing portions, the data behaves as expected. The reliability and validity of my procedures (using a different location from previous studies and an outdoor environment for the spatial memory test) is in line with previous research where these data have been reported. Because location trial estimates were generally very good, I will strive for a wider range of difficulty for location trials when designing future map-based navigation tests.

### Heading and Distance Estimate Adjustments

Scores for the heading and distance estimates were calculated for all of the above analyses using the correct distance and heading from the actual location that the participants were standing to the target landmark location. However, participants were not given feedback during the task and made their placement estimates before making heading and distance estimates. Participants therefore made their heading and distance estimates based on where they (correctly or incorrectly) *thought* they were standing (as opposed to where they were actually standing). I was concerned that the heading and distance estimates would not be independent of the placement estimates (i.e., people who do not do well at the placement task are more likely not do well on the other). In order to investigate this issue and whether there was an effect on the outcomes of the data, I calculated the heading/distance errors for each individual trial based on where participants thought they were standing when they made the estimates (that is, the correct location) and re-ran the analyses.

This re-calculation had only minor effects on the data and did not change any of the resulting conclusions. The main reason that these analyses would not have much of an effect is because most participants did reasonably well on figuring out their current location, so the distance adjustments were very minor in most instances (75% of participants had average placements that were within 18 meters of the correct locations). Considering that the mean error for distance estimates was 211.58 meters, the majority of the adjustments were too small to have major effects on study outcomes.



Heading adjustments also were barely affected because most people who wildly misidentified their location (were "lost") were not paying attention to the cardinal directions and/or relative position of landmarks within the park; they often made incorrect correspondences between something they saw in the environment and something on the map, which affected their perception of their location *and* heading. Not having a good understanding of their actual heading typically caused participants to orient their map incorrectly relative to target landmarks. Adjusting data that is essentially random results in the adjustments having both positive and negative effects on error (on average), with no net effect on the data. The fact that these adjustments had little effect on the heading error data further demonstrates the importance of correctly identifying your current location *and* heading when wayfinding in unfamiliar spaces.

### Video Game Learning

To explore whether participants in the Elder Scrolls or Portal training conditions improved from T1 to T2 as a result of their 10 hours of game play, I ran a series of 2(sex) X 3(video game condition) ANCOVA's for each of the performance variables using T1 test scores as a covariate. There was a main effect of condition on the mental rotation task ( $F(2,48) = 7.12$ ,  $p = .002$ ,  $\eta_p^2 = .23$ ) and post-hoc comparisons using Bonferroni correction shows that the Portal and Control groups had similar improvements from T1 to T2 with the Elder Scrolls group not improving as much (the MRT scores were transformed; lower scores = better performance). There was also a main effect of condition on a number of the self-report questionnaire variables (Factor 2 -  $F(2,48) = 3.35$ ,  $p = .044$ ,  $\eta_p^2 = .12$ ; Factors 2 and 3 combined -  $F(2,48) = 3.98$ ,  $p = .025$ ,  $\eta_p^2 = .14$ ; SBSODS -  $F(2,48) = 6.06$ ,  $p = .004$ ,  $\eta_p^2 = .20$ ). Contrary to predictions, follow-up post-hoc comparisons (Bonferroni) showed that participants in the No-Play control condition had significantly higher T2 scores after accounting for T1 than the Portal group did on *Factor 2* scores ( $p = .038$ ; see [Table 12](#)), on *Factor 2 and 3 combined* ( $p = .023$ ), and on the SBSODS ( $p = .001$ ), with the ES group falling in between the other groups but not being significantly different from either. These analyses indicate that 10 hours of game playing did not have a positive impact on participants' self-perceptions of navigation or spatial ability for either of the games used in this study. Because actual navigation scores did not change, it seems likely that playing the video games may have negatively influenced participants' *perception of their abilities*.

Table 11. Training Group Pre- and Posttest Means and Standard Deviations

	Elder Scrolls				Portal				Control			
	Pretest		Posttest		Pretest		Posttest		Pretest		Posttest	
	<i>M</i>	<i>SD</i>	<i>M</i>	<i>SD</i>	<i>M</i>	<i>SD</i>	<i>M</i>	<i>SD</i>	<i>M</i>	<i>SD</i>	<i>M</i>	<i>SD</i>
MRT	-2.03	0.77	-2.01	0.65	-2.44	0.99	-2.80	1.19	-2.30	0.75	-2.62	0.59
MVPT	57.80	3.58	59.35	2.32	59.00	4.01	59.95	3.02	59.80	2.33	60.40	3.03
PMT	0.63	0.15	0.69	0.14	0.62	0.23	0.71	0.16	0.61	0.19	0.71	0.14
RW Map Task	0.11	0.57	0.14	0.74	-0.05	0.60	-0.02	0.67	-0.16	0.54	-0.13	0.58
RW Spatial Memory	0.09	0.65	-0.08	0.74	-0.07	0.61	0.10	0.48	0.06	0.45	0.00	0.64
RW Nav	0.10	0.53	0.03	0.64	-0.06	0.45	0.04	0.46	-0.05	0.38	-0.07	0.51
Factor 2 – Navigation Skill	0.41	1.28	0.19	0.98	0.50	1.10	0.05	1.39	0.45	1.10	0.55	1.05
Factor 3 – Adv. Map Inst.	-1.41	1.22	-1.04	1.06	-0.70	1.67	-0.98	1.44	-1.55	1.09	-1.29	0.76
Nav Factor (2 & 3)	-0.07	1.10	-0.14	0.89	0.18	0.83	-0.22	1.24	-0.09	0.90	0.06	0.82
SBSODS	0.27	1.22	0.08	1.04	0.52	1.01	0.03	1.26	0.29	0.88	0.45	0.96
Spelling Test	52.95	2.78	53.65	2.52	52.80	3.02	52.80	3.52	53.85	2.81	54.20	3.44

The 2 X 3 ANCOVA's also revealed a main effect of gender: males improved at post-test more than females on the Mental Rotation Task, the Real-World Map Test, RWMT Pointing Error, and combined Real-World Navigation scores (see [Table 13](#)). There were no significant interactions involving T2 test scores and condition or sex. A lack of interactions in this data indicates that the different types of training did not have different effects on men and women.

Table 12. Training Group Post-Hoc Comparisons in Study 2

	<i>F</i> (2,48)	<i>p</i>	$\eta_p^2$	Elder Scrolls		Portal		Control	
				<i>M</i>	95% CI	<i>M</i>	95% CI	<i>M</i>	95% CI
MRT	7.12	<b>.002</b>	.23	-2.20	-2.44 to -1.96	-2.81	-3.09 to -2.53	-2.82	-3.16 to -2.48
MVPT	.36	.701	.02	60.10	59.04 to 61.15	59.60	58.54 to 60.66	60.29	58.75 to 61.83
PMT	.51	.601	.02	.646	.60 to .70	.646	.60 to .70	.678	.63 to .73
RW Map Task	.44	.647	.02	-.016	-.31 to .28	-.121	-.40 to .15	-.232	-.59 to .13
RW Spatial Memory	.90	.412	.04	-.169	-.41 to .08	.063	-.19 to .31	-.073	-.35 to .20
RW Nav	.31	.732	.013	-.110	-.30 to .08	-.020	-.21 to .17	-.119	-.34 to .10
Factor 2 – Navigation	4.04	<b>.024</b>	.14	.201	-.12 to -.52	.025	-.39 to .44	.720	.38 to 1.06
Factor 3 – Adv. Map Instruction	.23	.796	.01	-.95	-1.42 to -.48	-1.17	-1.67 to -.67	-1.11	-1.62 to -.60
Factor 2 & 3 – Nav Factor	3.95	<b>.026</b>	.14	-.086	-.36 to .19	-.376	-.72 to -.03	.245	-.05 to .54
SBSODS	7.44	<b>.002</b>	.24	.192	-.06 to .44	-.276	-.68 to .13	.654	.37 to .94
Spelling Test	.74	.484	.03	53.89	53.15 to 54.63	53.29	52.56 to 54.02	53.42	52.66 to 54.19

Table 13. Gender Difference Post-Hoc Comparisons in Study 2

	<i>F</i> (1,48)	<i>p</i>	$\eta_p^2$	Males		Females	
				<i>M</i>	95% CI	<i>M</i>	95% CI
MRT	9.72	<b>.003</b>	.17	-2.87	-3.17 to -2.58	-2.35	-2.51 to -2.19
MVPT	.60	.444	.01	60.27	59.01 to 61.53	59.72	59.04 to 60.40
PMT	1.49	.228	.03	.675	.63 to .72	.639	.606 to .671
RW Map Task	8.58	<b>.005</b>	.15	-.386	-.69 to -.08	.139	-.05 to .33
Pointing Error (RWMT)	4.72	<b>.035</b>	.09	1.07	.93 to 1.22	1.25	1.17 to 1.33
RW Spatial Memory	1.10	.299	.02	-.137	-.39 to .11	.017	-.14 to .18
RW Nav	7.56	<b>.008</b>	.14	-.241	-.43 to -.05	.075	-.05 to .20
Factor 2 – Navigation	2.01	.163	.04	.462	.11 to .82	.168	-.05 to .38
Factor 3 – Adv. Map Instruction	.757	.389	.02	-.95	-1.41 to -.49	-1.20	-1.54 to -.86
Factor 2 & 3 – Nav Factor	1.85	.181	.04	.046	-.25 to .34	-.191	-.38 to -.01
SBSODS	1.39	.244	.03	.298	-.03 to .63	.081	-.09 to .25
Spelling Test	.12	.735	.00	53.46	52.96 to 53.96	53.61	52.90 to 54.31

### Journal and Exit Survey Results

The journal and exit surveys allowed me to examine fidelity of training and whether there were differences in the participants' enjoyment of their assigned game. Participants were asked to complete 10 hours of training before coming back for their posttest, and to stop playing when

they had been playing that long; however, some participants played more or less than expected. Participants in the ES group reported in their game logs playing a mean of 10.5 hours and participants in the Portal group reported 9.8 hours (see Table 14 for other game play descriptives). In the Portal group, more participants played almost exactly 10 hours, whereas in the ES group, 9 of 20 participants went more than 15 minutes over. Considering the similar enjoyment ratings across games (reported below), I believe this is a side effect of the type of games (specifically, how easy it was to check the clock during play and the need to re-start failed levels in Portal) rather than an indication of greater enjoyment. There are fewer pauses in Elder Scrolls game play to pull the player out of their immersion in the game world (i.e., it is pretty easy to lose track of time for players who are enjoying the experience to some degree).

Table 14. Game Play Descriptive Statistics from Participant Logs

	Elder Scrolls				Portal			
	<i>M</i>	<i>SD</i>	<i>Range</i>		<i>M</i>	<i>SD</i>	<i>Range</i>	
Time Played (minutes)	630.9	70.0	540	836	587.5	98.7	393	900
Number of play sessions	8.6	3.5	4	17	8.4	3.6	4	17
Number of days playing	12.7	4.3	7	17	9.6	3.4	3	16

Participants in the ES group reported a mean of 8.29 ( $SD = 6.2$ ) looks per hour at the game map. Use of the map varied significantly; the 25th and 75th percentile were 3.08 and 10.71 looks per hour, with a minimum and maximum of .18 and 21.36. This data shows that most participants referred to the map a considerable number of times and 75% of participants looked at the map at least 30 times during their 10 hours of play. Participants also generally rated the game map as being relatively useful for playing the game ( $M = 1.13$  on a scale of -3 to 3( $SD = .63$ ); usefulness was measured by taking the average score of 9 questions related to how much they used the map and how much the map helped them achieve goals in the game).

Participants in both the ES and Portal groups reported mildly positive mean enjoyment ratings of their respective games with similar variability in the groups (ES:  $M = .47(SD = .75)$ ; Portal:  $M = .37(SD = .79)$ ); enjoyment was measured by taking the average score of 7 questions related to enjoyment on the General Exit Survey measured on a Likert scale from -3 to 3.

In the ES group, partial correlations controlling for gender were calculated for the number of looks at the map per hour (from the game-playing journal), participant reports of how useful the map was for playing the game (from the ES Exit Questionnaire), participant enjoyment of playing the game (from the General Exit Questionnaire), and difference scores from T1 and T2 on the main outcome variables of the study. Within the ES group, reports of map usefulness were significantly correlated with how often participants reported using the map in the game ( $r(15) = .518, p = .033$ ), but this correlation was somewhat lower than expected.

One possibility is that people repeatedly looked at the map precisely because they did not find it completely useful the previous time (i.e., they were having trouble interpreting it). Some evidence supports this conclusion: specifically, a marginally significant partial correlation controlling for gender between the reported number of looks per hour at the map and Factor 3 (Advanced Map Training) scores, with those reporting more map training at T1 looking at the map less while playing ( $r(15) = -.458, p = .065$ ), possibly because they could read it more easily. Another significant partial correlation was between the number of looks per hour (controlling for gender) and the difference scores from T1 to T2 for the mental rotation task (MRT). People who used the map more often than others and those who rated the maps as more useful for playing the game, showed *less improvement* from T1 to T2 on the MRT compared with those who found the map less useful and looked at it less often ( $r(15) = .553, p = .021$  and  $r(17) = .608, p = .006$ , respectively; lower score = better performance for the MRT). Pre-test MRT scores were not significantly correlated with ratings of usefulness ( $r(15) = .20, p = .41$ ) or looks at the map ( $r(20) = .33, p = .19$ ), so participants who rated the map as being useful and who looked at the map more were not simply better at mental rotation to start with. These correlations are somewhat difficult to interpret in the absence of more information about how participants played the games, but it is possible that people who did not find the map useful and did not look at it were using other sorts of non-map, in-game navigation techniques that may have required closer attention to character rotations (i.e., heading changes) or they may have spent less of their game time navigating and more time in “spatially intense” parts of the game (e.g., in combat). There were

no significant correlations between enjoyment of the games and the difference scores for any parts of the test battery (for both ES and Portal;  $N = 37$ ). This is a good indication that motivation to perform at T2 was not heavily influenced by having a good or bad experience with the game. Ratings of map usefulness were not correlated with any of the other difference scores.

In the ES group, total looks at the game map were correlated with improvement (from T1 to T2) on Real-World Map Task Placement Trials ( $r(18) = .503, p = .033$ ), marginally with improvement in RWMT Heading Trials ( $r(18) = .442, p = .066$ ), and with improvement on the overall RWMT ( $r(18) = .534, p = .022$ ). After controlling for gender, none of these correlations remained significant due to a reduction in degrees of freedom, but they do retain much of their magnitude ( $r(15) = .365, p = .150, r(15) = .435, p = .081, r(15) = .427, p = .087$ , respectively). Despite the lack of a main effect of condition, this set of within-group correlations provides some evidence that participants who used the map in the ES group performed better on parts of the RWMT at post-test. These correlations indicate that some learning may take place from using maps in video game environments, but also highlight the need for players to gain more (or better) exposure to game maps in order to realize significant improvements at the group level.

Because the *Elder Scrolls* is a non-linear game, progress is hard to measure objectively due to the different goals on which participants can choose to spend time. However, I was able to collect information about progress in Portal by calculating rate of progress as minutes of play time per distinct level. Rate of progress was not significantly correlated with any of the T1 test scores, especially after controlling for gender. However, a faster rate of progress and final level achieved in Portal were correlated with difference scores between T1 and T2 for the Motor-Free Visual Perception Test ( $r(14) = .568, p = .022$  and  $r(14) = .729, p = .001$ , respectively). These correlations seem to indicate that the speed of play has an influence on the ability to learn visual-spatial skills from video games. They may also indicate that some participants needed more playing time and/or that some participants needed to get farther into the game in order to observe improvements in their visual-spatial abilities.

## Gender Differences

### Pre-Test (T1) Differences

At T1, males outscored females on a number of tests including Mental Rotation, the Photo-Map Task, and Pointing Error on the Real-World Map Test (see [Table 15](#); data from all 78

participants who completed the pre-test). Males also reported more navigation skill on several questionnaire factors: Factor 3 (Advanced Map Training), the Navigation Factor (2 and 3 combined), and the SBSODS.

Table 15. Gender Differences at Time 1

	<i>t</i>	<i>p</i>	<i>d</i>	Males		Females	
				<i>M</i>	<i>SD</i>	<i>M</i>	<i>SD</i>
MRT	2.68	<b>.009</b>	.67	-2.68	.81	-2.06	.95
MVPT	-1.23	.222	.31	59.13	3.12	58.02	3.78
PMT	-3.24	<b>.002</b>	.74	.64	.12	.55	.12
RW Map Task	1.68	.098	.42	-.17	.69	.07	.52
Pointing Error (RWMT)	2.52	<b>.014</b>	.60	1.15	.27	1.30	.24
RW Spatial Memory	1.25	.216	.31	-.15	.57	.06	.70
RW Nav	1.80	.075	-0.44	-.16	.48	.06	.50
Factor 2 – Navigation	-1.91	.060	.48	.78	.86	.22	1.25
Factor 3 – Adv. Map Instruction	-2.46	<b>.016</b>	.61	-.72	1.97	-1.55	1.01
Factor 2 & 3 – Nav Factor	-2.6	<b>.010</b>	.65	.38	.99	-.25	.94
SBSODS	-2.39	<b>.019</b>	.59	.72	.89	.11	1.06
Spelling Test	1.23	<b>.222</b>	-0.31	52.82	3.03	53.71	2.83

#### Journal and Exit Survey Sex Differences

A number of sex differences emerged from the journal and exit surveys that indicate, even within a non-game playing sample, that the males performed better at and enjoyed playing



the two video games somewhat more than the females (See Table 16 for data from this section). In the game playing journals that participants filled out, the females reported more total time played (629 vs. 572 minutes), yet they also reported more frustration with Portal, were less likely to report being interested in buying other video games after being in the study, and were marginally less likely to report enjoying the games. Enjoyment ratings were calculated from the average response to 7 related questions (e.g., I enjoyed playing the game I was given, I felt like it was a chore to play the game the required amount of time, I easily lost track of time while

Table 16. Journal and Exit Survey Gender Differences

	<i>t</i>	<i>p</i>	<i>d</i>	Males		Females	
				<i>M</i>	<i>SD</i>	<i>M</i>	<i>SD</i>
Total Time Played (minutes)	2.06	<b>.046</b>	0.67	571.86	79.3	629.27	86.0
Longest Session	1.67	.103	0.57	183.38	107.7	133.83	69.9
Number of Sessions	2.46	<b>.019</b>	0.74	6.92	2.3	9.45	3.8
Mean Enjoyment Rating (avg. of 7 items on 5-point scale)	1.90	.065	0.87	0.72	0.7	0.26	0.8
Considering Buying Games	2.61	<b>.013</b>	1.15	0.21	1.1	-0.77	1.1
Minutes to Complete Portal Level	2.39	<b>.030</b>	0.60	22.66	9.54	34.38	9.68
Portal Frustration (low score = more frustrating)	2.31	<b>.033</b>	0.85	0.43	1.3	-0.62	0.8
Usefulness of Map in Elder Scrolls	1.99	.065	0.67	1.45	0.47	0.96	0.9
Frustration With Finding Things in Elder Scrolls	3.11	<b>.006</b>	0.57	1.29	0.76	-0.23	1.42
Map Use for Elder Scrolls	1.81	.089	0.74	116.9	66.6	64.6	55.1

playing the game, etc.). Males also tended to take less time per level on Portal (22.7 vs. 34.4 minutes), to report less frustration with the experience of using the game map in ES to find goals in the game world, and they tended to report using the maps more.

## CHAPTER VII

### DISCUSSION

Using real-world testing data at T1, I demonstrated the difficulty that many participants had in real-world navigation testing, especially in making Heading and Distance estimates. These failures are particularly striking for the real-world map task, since a very simple park map, using conventions similar to widely available Google maps, provided all information that was necessary to respond accurately. Given these difficulties and room for improvement, I expected that individuals playing the *Elder Scrolls IV* would learn and transfer navigational skills to the real-world testing situation. This hypothesis was not supported. There is some evidence within the ES group that participants who used the map more often were more likely to learn navigational skills. Considering that over 75% of the sample referred to the game map at least 30 times over the course of the study, most participants appear to have received a considerable amount of additional map experience compared with participants in the two control conditions (*No-Play* and *Portal*). In sum, these data suggest that either significantly more game time is required to provide more experience for those who did not use the map as regularly or that there was something about the learning situation that was not very effective.

One possibility for the lack of learning of navigation skills is the absence of body-based cues during navigation in a desktop virtual environment. Some prior research has shown that body-based cues are important for the construction of accurate mental representations of a space (Ruddle & Lessels, 2006; Bakker, Werkhoven, and Passenier, 1999). A lack of such cues could have prevented participants in this study from creating coherent enough representations of the video game environment to be able to learn navigational skills. The possibility also remains that certain navigational skills are unlikely to improve following experience in desktop VE's (specifically, highly practiced skills and those that desktop setups are poor at replicating). However, research has indicated that body-based cues may not be important for transferring spatial *information* (such as configural knowledge of a building) from a VE to a real-world location (Wilson, Foreman, & Tlauka, 1997; Péruch, Belingard, & Thinus-Blanc, 2000; Waller, Hunt, and Knapp, 1998). Also, learning many basic map skills would seem to require little, if

any, movement in space (e.g., learning to use the scale depicting distance from a map key). Even without body-based movement cues, participants' ratings of the usefulness of the map were largely positive or neutral and they regularly used it; they seemed to be able to draw the connection between what they were seeing in the game world and on the map. Therefore, it is possible that the lack of learning was not from lack of body-based cues but due to some other factor like the auto-updating features of video game maps (see General Discussion).

Males outscored females at pre-test on the Mental Rotation Task and Photo-Map Task. They showed a significant advantage in the real-world navigation testing only on pointing error from the Real-World Map Test. They also were more likely to report having had Advanced Map Training and better navigation skills (on the Navigation Factor and the SBSODS). These effect sizes ranged from medium (Advanced Map Training = .48) to large (Photo-Map Task = .74) and are generally consistent with prior research showing a strong mental rotation advantage for males and smaller (or less consistent) advantages on navigation measures.

I expected to find a positive impact of game playing on basic visual-spatial abilities, especially on scores from the Mental Rotation Task and particularly for female players (Feng, et al., 2007). I did not find a specific effect of game playing on visual-spatial abilities for either of the video game playing groups, regardless of sex. This was surprising, because females performed worse at T1 on a number of the spatial and navigation measures and, presumably, those who start with lower scores would find it easier to improve. Prior research has shown that mental rotation training is particularly effective for females and I expected females performing more poorly at pre-test to "catch up" at post-test.

Considering other recent failures to replicate aspects of the Feng et al. study (Murphy & Spencer, 2009), it seems worthwhile to explore the differences between that research and the study reported here. Although Study 2 could have benefitted from more power, my sample size was twice that used by Feng et al., so a lack of power in detecting the effect is unlikely to be the explanation. Different from the lab-based game play in Feng et al., participants played at home to make Study 2 as naturalistic as possible. Although I have verified that participants played and progressed through the games (using "save game" files and playing logs), I have little information regarding the degree to which participants concentrated during the playing sessions. Because participants were not required to schedule their playing time with lab personnel, many tended to mass their game play toward the end of the training period and in larger blocks of time.

Conversely, some participants played in very small chunks throughout the period, which may not have allowed them to get as immersed as others were in the experience; they may have spent proportionally more of their reported game playing time moving through menus and loading the games. Finally, there are a number of differences between the games used in Feng et al. and the current research, which are discussed in the General Discussion.

## CHAPTER VIII

### GENERAL DISCUSSION

Navigation is not an easy task for many individuals. The difficulty I had in getting some participants to the testing location illustrates this point. A very detailed Google map that I supplied to help participants find me in Centennial Park, including a route drawn from the main road passing the park (West End Avenue) to the meeting location was not sufficient. Specific written directions from all of the major highways had to be added to the map to cut down on the number of people getting lost while trying to find the most recognizable park in the city. The trouble that even adults have in navigation tasks using a map is a clear indication of the need for more formal navigation instruction and experience.

Once they found the meeting location, a number of the individuals who got lost said, "I knew I was going to get lost" or "I have a terrible sense of direction." Indeed, this set of studies has shown that people are reasonably capable of reporting their own navigational abilities. However, the factor structure of the questionnaire data in Study 1 suggests that people do not readily make a strong distinction between memory-based navigational skills and map-based navigational skills, unless those questions specifically relate to the training of *advanced* map skills. This is the case even though evidence from real-world testing in Study 2 suggests that map-based and memory-based navigation skills are distinct. Nonetheless, both skill sets are important for accurate navigation in novel environments and there is considerable overlap in how they are used in everyday experiences.

With the above in mind, I will provide some observations regarding the four main goals of this set of studies: 1) determining if navigational skills can be learned in VE's and transferred to solve novel navigation problems in real-world environments; 2) clarifying the relationship between video game playing and visual-spatial and navigation ability with a mind to how differences in game design might account for differences in outcomes; 3) exploring sex differences in navigation, spatial ability, and video game play; 4) developing reliable, valid, easy-to-administer measures of navigation ability.

## 1. Transfer of Navigation Skills from Video Games to the Real World

Since the participants in Study 2 clearly had room to improve their navigational skills and many of the participants readily used the game maps, I expected that individuals playing the *Elder Scrolls IV* would show evidence of learning and transfer of navigational skills from that virtual environment to the real world testing situation. Despite the focus on exploring the terrain in order to locate valuable items within the Elder Scrolls game world, this hypothesis was not supported. There is also no evidence, looking within the ES group, that individuals using the map more often were more likely to learn navigational skills. Considering the amount and range of map use it seems rather unlikely that the lack of learning was simply due to participants not receiving enough additional map exposure.

The most important prerequisite for being able use a map to navigate through a novel environment and to a desired destination is the ability to figure out one's current location and heading (the direction one is facing). Research on "you-are-here" maps has demonstrated that people reading a static map that is unaligned with the space being portrayed produce more errors in choosing an appropriate heading to a target location, compared to those who experience the map aligned to the space (Levine, Marchon, & Hanley, 1984). These additional errors are attributed to the misalignment creating difficulty in accurately estimating one's current heading in relation to the goal. You-are-here maps, by their very nature, always provide one piece of the necessary information (one's current location). In fact, they also often indicate heading, either by using an arrow to show the direction one is facing or by aligning the map so that the top indicates the direction in front of the user. This research highlights the importance (and difficulty) of correctly judging one's current position and heading prior to making decisions about the correct heading to and distance from a destination.

Many GPS systems and most video game maps have a marker that indicates and *automatically updates* both of these critical pieces of information (position and heading). This extra assistance undoubtedly makes navigation much easier, which undoubtedly is why the designers of these systems incorporate those elements. Research has already demonstrated that offering turn-by-turn directions limits the amount of spatial information users are able to accumulate and recall (Parush & Berman, 2004; Burnett & Lee, 2005). Having auto-updating information readily available also reduces the need for a navigator to make important navigation decisions. Thus, turn-by-turn directions and auto-updating location/heading information likely

reduce the amount of actual navigation experience users of these systems are accumulating.

In recent years, vehicle-based and handheld GPS systems have proliferated. With growing popularity have come more stories of individuals, to their peril, blindly following the verbal instructions and virtually plotted routes that these systems produce. Although GPS systems obviously have great utility, the technology has its limitations, and failures are common. First, these systems limit the ability of participants to encode and recall *specific spatial information* about environments they have experienced. Second, compared with more traditional navigation methods such as using maps and compasses, these systems also may limit the ability of individuals to learn new navigational *strategies* and *skills* from those experiences. If that is the case, the end result of the proliferation of these sorts of auto-updating navigational tools may not only be a diminished spatial representation of previously experienced environments, but also more difficulty navigating in novel spatial environments when experiencing them *without* GPS. These systems also may encourage people to use more route-based strategies as they create spatial representations of their environment. Route knowledge relies on direct experience of the environment. Navigation strategies relying solely on that type of experience do not promote the learning of survey knowledge of spaces as well as the combination of direct experience *and* maps do.

The good news is that careful design of GPS systems (and presumably video game maps) should be able to overcome some of these limitations (Oliver & Burnett, 2008) without sacrificing the ultimate goals of the companies that design them. Road-based GPS systems are primarily concerned with getting people quickly, efficiently, and safely from point A to point B. There is little financial incentive for these companies to invest in the development of interfaces that increase spatial awareness if such come at the cost of increasing cognitive load and making short-term navigation goals more difficult to accomplish. However, if these systems can continue to help people accomplish short-term navigation goals *and* increase overall spatial awareness and navigational competence, customer satisfaction with the product should allow companies to reap the benefit of those investments. GPS systems designed to be more map-like are used for activities such as hiking, navigating boats, plotting the location of specific objects in the environment (e.g., species of trees), etc. These systems are less constrained by many of the safety and efficiency concerns that consumer-grade road-based GPS systems must address, so there may be more freedom in their design. However, because many GPS and other computer-



based systems exist primarily to fulfill short-term navigation goals or very specific functions, interfaces and equipment specifically intended to teach map/navigation skills may need to be developed as separate products.

In future research, disabling access to the in-game map and having participants use a printed map could address concerns about the auto-updating features of the game, or development tools could be used to limit what information is displayed on in-game maps. For example, the code for many games could be edited so that the map portrays the player's current position but not heading information. Alternatively, static maps more closely resembling paper maps could be provided on the screen in place of auto-updating versions.

A guiding principle of this study was to make the training as naturalistic as possible so that the findings could be applied to the everyday lives of video gamers, a significant portion of the population. Manipulating the game displays would certainly deviate from that principle since the practice of having games display and update position and heading information is fairly ubiquitous. However, such a manipulation would also provide a strong test concerning the role of auto-updating features versus determining this information oneself in the learning of navigational skills.

Another possible explanation for the ineffectiveness of the training is the relatively small amount of time participants played. Prior to this study, I hypothesized that video game experience would affect some, but not all, spatial abilities. For instance, I predicted that such experience would not affect performance on the real-world spatial memory test because memory-based navigation (e.g., finding one's way to a familiar location) may be "over-practiced"; 10 hours of game play provides relatively little experience in relation to that encountered in everyday life. However, map use for navigation is not a daily occurrence for most people, nor is it explicitly taught, so improvement was expected. Nonetheless, the amount of experience offered could be an important limitation of Study 2 for improving map-based navigation. A 10-hour training period was selected because Feng et al. (2007) found an effect of this amount of game playing on several basic-level visual-spatial measures. For children or other less experienced navigators, 10 hours of simplified, GPS-like navigation experience may have been helpful. However, almost all of the participants in this study were old enough to have accumulated a reasonable number of opportunities for self-guided navigation to improve their skills, even if they had not had formal training and do not wayfind on a regular basis. A longer

training period may be required for adult participants to experience a benefit from playing, especially with the kind of navigation assistance many games provide. A less experienced sample (e.g., teens who do not yet drive or regularly self-navigate while venturing far from home) may show greater benefits with less exposure.

Finally, although this research did not directly test for the effects of body-based cues on knowledge gained from VE's, it was based on the premise that people could create coherent mental representations of VE's with good enough fidelity to allow *general wayfinding skills* to be learned in desktop VE's. Past real-world research has shown that paper maps facilitate acquisition of survey knowledge (Thorndyke & Hayes-Roth, 1982), suggesting that they should help support the learning of skills and spatial knowledge from VE's and on-screen maps. However, past research has also shown the importance of body-based cues in the acquisition of spatial knowledge (Ruddle & Lessels, 2006; Bakker et al., 1999) and one of the main differences between real-world and desktop virtual environments is a lack of body-based cues. Since participants did not show evidence of learning in this study, it is possible that the presence of body-based movement cues along with visual input plays a role in the learning of maps skills.

There are a number of interesting areas of future study related to body-based cues. To better understand the role of expertise in mitigating the effects of such missing cues, future studies could use expert players of first-person video games who have automatized standard video game control schemes (e.g., a keyboard and mouse). Alternatively, one could examine spatial knowledge or skills in a sample of people accustomed to navigating in electric wheelchairs (that is, people who are experienced at moving through visual space without the typical body-based cues). To my knowledge, no research examines how expertise may influence individuals' ability to compensate for a lack of body-based cues in their navigation of space, or how that expertise may alter distance estimation or the fidelity of mental representations of space.

## 2. Video Game Playing, Spatial Ability, and Game Design

In Study 1, I found few and relatively weak relationships between people's preference rankings for the playing of specific game types and their responses to the navigation factors. This is likely due, in part, to the variety of game designs included in a single genre category as well as a reasonable amount of overlap in the type of skills used across categories. Future

attempts to assess genre preference should use more fine-grained distinctions than the ones used in Study 1.

It is also possible that self-selection limits the ability to find these relationships; in my sample heavier game players were more likely to play role-playing and shooter games, which appear to be the more spatially-demanding genres. Time spent playing video games may replace other spatial activities. For example, one of the motivations for this study is the observation that children today are less likely to be getting real-world navigation experience (Subrahmanyam, Kraut, Greenfield, & Gross, 2000) and that experience is more likely to come in the form of navigating virtual environments in video games. If people choose to fill their time with video game playing, they probably have less time or put less of a focus on participating in other activities (such as sports, travelling, hiking, etc.), some of which may have an effect on spatial skills. In such a case, any effect of video game playing would simply be washed out in the correlational design used in Study 1.

Considering that previous research has shown an effect of games on visual-spatial ability (Subrahmanyam & Greenfield, 1994; Green & Bavelier, 2003; Castel, Pratt, & Drummond, 2005), I expected to find a differential impact of playing the 2 types of video games (*Elder Scrolls* and *Portal*) on basic-level spatial abilities in Study 2 (specifically mental rotation—Feng et al, 2007). However, I did not find training effects for either group on basic-level spatial abilities, which makes the exploration of differences between the two game types difficult. Nonetheless, an examination of the games used in this study in comparison to the game used in Feng et al. (2007) may be informative.

In both studies, participants got 10 hours of experience playing video games that had a first-person perspective and realistic/detailed looking (albeit fantastic) environments. Both of the games also incorporated some elements associated with traditional first person shooter (FPS) games, including the first-person perspective and the typical FPS control interface for computers (using the mouse to control the heading of the character, the “W” and “S” keys for backward and forward motion, and “A” and “D” for strafing--moving left and right). Despite the similarities, the games used in the two studies are different in some important ways. *Elder Scrolls* does contain combat elements similar to FPS, including aiming (e.g., deploying spells and shooting bows). However, these high action parts of the game are intermingled with longer spans of activity that are less visually or spatially demanding (story building, talking with people in the

game world, exploring, etc.) and even the most visually intense parts of this game are not on par with many shooters.

Portal uses a FPS game engine, but the gun in the game is only used for deploying portals and there are very few enemies (all of whom are stationary). Some parts of the game do require players to accurately chain together precise movements to get past obstacles, and portals regularly change the orientation of the player in relation to the game world. These orientation changes require participants to predict how movement through the portals will affect the character's view and to quickly re-orient to the game world. Because these skills are very similar to the requirements of a mental rotation task, I expected to see improvement on that task. Nonetheless, this is a puzzle game. The primary challenge is in figuring out how to traverse the environment, not quickly identifying and responding to targets on the screen in order to survive in the game world. The action elements associated with target detection and three-dimensional tracking in FPS, all of which were present in the game used by Feng et al. (2007) are simply not present in large portions of this game.

Because the selection of these games was primarily based on their appropriateness for the teaching/learning of navigation skills and as a control condition, these differences in the games were somewhat unavoidable. However, they do suggest that the action elements of FPS games (requiring more constant vigilance and faster identification of and response to multiple potential targets and threats), and not solely the first-person perspective or realistic environments, are the key for building visual-spatial processing skills using video games. Since both of these games contain some action elements, it is possible that these skills would have accumulated over longer training periods. Alternatively it could be the case that the massed experience created through the constant action and vigilance required in FPS games is paramount. Future research is needed to clarify the mechanisms behind visual-spatial training from video games and for determining what elements of the game design are important. Nonetheless, the outcomes of this research are consistent with the literature that has demonstrated that elements of the game design are important in determining what can be learned and how readily that learning occurs. It also adds to that body of knowledge through the incorporation of two video games that, except for a few key elements, have designs closely resembling other games that have been found effective in training spatial ability.

### 3. Sex Differences in Navigation, Spatial Ability, and Video Game Play

There were a number of significant sex-related differences throughout both of the studies reported here. Males were more likely to play video games, a pattern seen in Study 1 and reflected in my difficulty recruiting non-playing males for Study 2. Males also were more likely to self-report greater navigation ability and to demonstrate greater ability in certain aspects of the testing situation. These observed differences are in agreement with the majority of the past literature on video games and spatial and navigation abilities, specifically that males have a particularly strong advantage in mental rotation ability (Linn & Petersen, 1985) with less pronounced or consistent advantages for other aspects of navigation (Montello, Lovelace, Golledge, & Self, 1999). Because we did find pre-test sex differences for a number of the variables in Study 2, and because we controlled for video game playing in that study, we know that the presence and maintenance of those sex differences were not, in a direct way, caused by differences in video game experience. This conclusion is further bolstered by the fact that playing the games from this study did not have a positive impact on male or female task performance.

Males in Study 2, regardless of condition, did experience an increase in scores on a number of measures from T1 to T2 in comparison to females. This increase is difficult to explain, particularly because it happened even in the control condition. I found no systematic evidence of pre-test expertise having an influence on post-test performance (positively or negatively) in either males or females, so prior expertise fails to explain the male performance increase. The most likely explanation involves motivation differences resulting from gender expectations. During the testing sessions, a number of males and females in this study asked me about gender differences on the tests being used. In doing so, many specifically mentioned that they expected males to be better. When this topic came up, I never discussed gender differences with participants and simply mentioned that I would be looking to see if there were any in the study. However, it did seem to be general "folk knowledge" in my sample that males are "naturally" better navigators. A desire to live up to those expectations could have helped to create a self-fulfilling prophecy, with males paying more attention to the details of the testing situation or simply being more motivated to perform well at T2. It is also possible that males were simply more attracted to the games. The majority of current game design and marketing is directed at males, so they may have had an overall more positive outlook on the study. However,

this explanation does not account for a lack of sex differences in the overall enjoyment of the games according to posttest exit questionnaires, it does not account for the control group improving unless we again make the assumption that males simply paid more attention to the details of the testing situation, and it would be surprising if the males were that much more motivated due to an affinity for games since all of the participants in the training study were non-players.

#### 4. Navigation Measure Development

Another main focus of this study was to try to develop a number of new measures to allow for easier and better assessment of video game experience and navigational skills. These include a *Video Game Experience* scale and two questionnaire scales for measuring aspects of navigation (*Navigation Skill* and *Advanced Map Instruction*). A multiple-choice *Photo-Map Task* for in-lab testing of map use skills, based on an open-ended version used with children (Liben et al., 2002), will be the subject of ongoing development. I will focus on creating easier items and bringing in items from a variety of new locations to increase its validity and reliability. Nonetheless, the Photo-Map task has been a useful measure in the context of this study and shows promise as an easy to administer in-lab assessment of skill in using maps.

According to the reliability and validity information from this set of studies, all three questionnaire scales (Video Game Experience, Navigation Skill, and Advanced Map Instruction) are reasonable measures of their associated constructs. The Video Game Experience scale is the first of its kind developed with such a large sample. In regards to navigation and map experience, the power of the factor analysis from this study was greater than that using the original development sample for the Santa Barbara Sense of Direction Scale (Hegarty et al., 2002) and indicates reasonable validity and reliability for the SBSODS. However, the current results suggest that the shorter Navigation Skill scale has equally good reliability and validity, and is a purer measure of the construct. In combination with the Advanced Map Training scale, it may be a better measure of self-reported perceptions of overall navigation ability (including memory-based *and* map-based skills) than the SBSODS. In response to some promising results from Study 1 involving a relationship between early spatial/navigational experience and current reports of navigation ability, I will attempt to create a more coherent scale of the early experience construct in future research.

## Conclusion

Video game playing is a common leisure time pursuit of a significant portion of the population. This set of studies used multiple methods to assess the possible use of video game playing as a replacement or supplement for navigation experience in the real world. Although games and simulations should still be considered a promising medium for teaching and for learning visual-spatial and navigational skills, this research has underlined the need for the conscious design of educational elements and the careful tailoring of virtual experience to stated educational goals. Specifically, this study helped clarify that providing location and heading information (in video game maps and GPS systems) may limit the amount of spatial learning that occurs while using such devices. Navigation in video games likely is of secondary concern for game development teams; it is not something that most game players would consider an interesting, enjoyable part of the gameplay. However, the need to navigate is very noticeable to players when getting around in the game world becomes annoying or frustrating. As a result, game companies are motivated to oversimplify navigation. There is no benefit to frustrating their player base by forcing them to use more advanced or difficult navigational techniques. The apparent need for more conscious design of educational elements undercuts the possibility that video games, as they are currently constructed for the mass market, could be used to fill an overlooked educational niche.

This study is the first attempting to find far transfer of skills (as opposed to place knowledge) from a virtual environment to a real world situation. Therefore, a significant portion of this research was exploratory. Despite its exploratory nature, the research identified a number of future directions for study, provided a foundation on which to base that research, further described sex-related differences in the areas of visual-spatial ability and navigation, and led to the development of a number of easy-to-administer measures that will be useful for future navigation research.

## APPENDIX A

### MAJOR VIDEO GAME GENRES

Category	Subcategory
Shooter	First-Person Shooter ( <i>Doom, Medal of Honor</i> ) Third-Person Shooter ( <i>Tomb Raider, Gears of War</i> ) Tactical Shooter ( <i>Operation Flashpoint, Ghost Recon</i> ) MMO First-Person Shooter ( <i>Battlefield 1942, PlanetSide</i> )
Sports	Sports ( <i>Madden Football, FIFA Soccer</i> )
Action	Light Gun Game ( <i>Duck Hunt, Time Crisis</i> ) Scrolling Shooter ( <i>Star Fox, 1942</i> ) Arcade Racing ( <i>Out Run, Mario Kart</i> ) Racing Simulation ( <i>Gran Turismo, Forza Motorsport</i> ) Vehicle Combat ( <i>Twisted Metal, Road Rash</i> ) Action Adventure ( <i>Legend of Zelda, Metroid</i> ) Beat 'em Ups / Hack 'n' Slash ( <i>Double Dragon, TMNT</i> ) Fighting ( <i>Super Smash Bros., Mortal Kombat</i> ) Wrestling ( <i>WWE Smack Down vs. Raw, Total Extreme Wrestling</i> ) Party ( <i>Mario Party, Warioware</i> ) Arcade ( <i>Donkey Kong, Frogger</i> ) Platformer ( <i>Mario, Sonic the Hedgehog</i> ) Pinball ( <i>Visual Pinball, Full Tilt! Pinball</i> )
Adventure	Adventure ( <i>Myst, Trace Memory</i> )
Role-Playing Games	Action RPG ( <i>Diablo, Titan Quest</i> ) Tactical RPG ( <i>Final Fantasy Tactics, Shining Force</i> ) MMORPG ( <i>World of Warcraft, Everquest</i> )
Simulation	Flight ( <i>Microsoft Flight Simulator, X-Plane</i> ) Space ( <i>Orbiter, Microsoft Space Simulator</i> ) Military ( <i>Abrams, Silent Hunter</i> ) Train Sim ( <i>Trainz, Railroad Tycoon</i> ) God Games ( <i>The Sims, Spore</i> ) Economic Sim ( <i>SimCity, Tycoon series</i> )
Strategy	Tactical Strategy ( <i>Total War, Silent Storm</i> ) 4X - eXplore, eXpand, eXploit, eXterminate ( <i>Sid Meier's Civilization, Warcraft</i> )
Music	Singing ( <i>Singstar, Karaoke Revolution</i> ) Rhythm ( <i>Dance Dance Revolution, Rock Band</i> )
Other	Traditional - card games, board games, etc. ( <i>Solitaire, Othello</i> ) Artillery ( <i>Gunbound, Scorched Earth</i> ) Maze ( <i>Pac-Man, Mummy Maze</i> ) Brain Training ( <i>Brain Age, Lumosity</i> ) Puzzle ( <i>Minesweeper, Portal</i> )

Genre information summarized from data downloaded from Wikipedia  
([http://en.wikipedia.org/wiki/Video\\_game\\_genres](http://en.wikipedia.org/wiki/Video_game_genres)) on 12/03/2007



## APPENDIX B

### STUDY 1 QUESTION TYPES

Main Categories	Sub-Categories	Description	Question Type
1. Technology Use	A. Gaming Consoles	Participants indicate, from a list of possibilities, which video game consoles they own (e.g., PlayStation 3, Xbox 360, etc.)	Points assigned based on age of console (more systems and more recent system = higher score)
	B. Computers	Questions about computer ownership	Varied
	C. Map Access	Questions about use and ownership of navigation aids including maps, GPS, Google earth, a globe, etc.	Likert Scale (Used Daily, 5, to Never heard of it, 1)
	D. Online Gaming	Questions about whether or not participants have accounts with major online and/or browser games (World of Warcraft, Second Life, Travian, etc.)	Likert Scale (Used Daily, 5, to Never Heard of It, 1)
2. Opinions and Practices	A. Self-Navigation	Questions about opportunities for self-navigation as a child	Likert Scale (Agree, +2, to Disagree, -2)
	B. Visual-Spatial Activities	Questions about participation in visual-spatial activities	Likert Scale (Agree, +2, to Disagree, -2)
	C. Urban / Rural Living	Questions about past/present living environment	Likert Scale (Agree, +2, to Disagree, -2)
	D. Map Skill	Questions about participant's perceived skill at using a map and wayfinding in different situations	Likert Scale (Agree, +2, to Disagree, -2)
	E. Map Experience	Questions about prior experience with using maps including explicit training (e.g., military/job training)	Likert Scale (Agree, +2, to Disagree, -2)
	F. Video Game Experience	Questions about number of video games owned and number of hours playing different games	Open Ended
3. Video Games	A. Maps in Video Games	Questions about the participant's past experiences using maps in video games.	Likert Scale (Agree, +2, to Disagree, -2)
	B. Interest in Video Games	Questions about preference for gaming compared to other daily activities	Likert Scale (Agree, +2, to Disagree, -2)
	C. Video Game Skill	Questions about the participant's perception of their skill at playing video games compared to others	Likert Scale (Agree, +2, to Disagree, -2)
4. Video Game Preferences	A. Favorite / Least Favorite Games	Participants list their 3 favorite and 3 least favorite games that they have played	Open Ended
	B. Game Type Rankings	Rank video game types according to interest in playing them	Rank 9 video game types from 1-9 (1 = most interest in playing)
5. Santa Barbara Sense of Direction Scale	A.	15 questions about navigation and sense of direction skills and interests (see Hegarty et al., 2002)	Likert Scale (Agree, 1, to Disagree, 7)
6. General Information	A.	Questions about country of residence, zip code, income, birthday, occupation, education, sex, and race/ethnicity	Varied

APPENDIX C

MEASURES USED IN STUDY 2

Assesses	Procedure	Time (mins)	Reliability*
Video Game Playing	<i>Video Game Screening Questionnaire</i> – Questionnaire administered by e-mail prior to enrollment in the study to assess participants’ exposure to video games and their playing habits. Only individuals with little or no game play were invited to participate.	5	N/A
Self-Reported Navigation Skills	<i>Navigation and Map Use Questionnaire</i> – Collected self-reports of participants’ experience with navigation, map use, and their sense of direction. 24 questions plus 15 questions from the SBSODS (below).	10	Observed: $\alpha = .86$ and $.72$ for factors 2 and 3 (see Table 2)
	<i>Santa Barbara Sense of Direction Scale (SBSODS)</i> – A 15-item scale with questions relating to spatial awareness and navigation by Hegarty, Richardson, Montello, Lovelace, & Subbiah, 2002.	N/A	Reported – $\alpha = .88$ Observed – $\alpha = .86$
Navigation	<i>Photo-Map Task (PMT)</i> – Using photos of public places (a mall, a college campus, and a large hotel) displayed on the computer screen, participants identified on a map the location from which the photograph was taken (adapted from Liben et al., 2002). 30 trials, displayed in random location-specific blocks of 10. Before each location block, participants had 30 seconds to view an overview map, which included the map key and all locations used in the trials.	15	Observed (all locations) – Study 1: $\alpha = .52$ Study 2 test-retest: $r = .707$
	<i>Real -World Map Test (RWMT)</i> –While being taken along a route through the park, participants were stopped at 3 specified locations. At each, they were asked to locate their position on a park map (placement trials), and indicate the position of 2 other distant, unseen landmarks (distance and heading estimates). This task is designed to mimic map-based wayfinding techniques.	20	Observed – Location Error Ranks – $\alpha = .59$ ; Distance** – $\alpha = .74$ ; Heading – $\alpha = .53$

Continued on p. 99 and 100

APPENDIX C CONTINUED

Assesses	Procedure	Time (mins)	Reliability
Navigation Cont.	<i>Real-World Spatial Memory Test (RWSM)</i> – adapted from Hegarty, Montello, Richardson, Ishikawa, & Lovelace (2006) – A measure of spatial learning that required participants to learn the layout of the location of 4 landmarks while being led on a set route through the park. After the first circuit, participants were taken back to the beginning of the route and followed the same route again, stopping at each landmark and making straight-line distance and direction estimates to each of the other 3 non-visible landmarks.	35	Reported – Heading – $\alpha$ = vary from .85 to .66 Distance – N/A  Observed: Distance** – $\alpha$ = .85; Heading – $\alpha$ = .64
Visual-Spatial Ability	<i>Mental Rotation Task (MRT)</i> – A computer-based adaptation of Shepherd and Metzler’s (1971) stimuli requiring individuals to determine if two shapes match or not by mentally rotating and comparing them. Computer tracked the accuracy of the judgments and reaction times. 50 randomly selected trials (10 each of 20°, 60°, 100°, 140°, and 180° rotations).	10	Reliability: Reported – $\alpha$ = .88, test-retest reliabilities vary between .70-.88  Observed – $\alpha$ = .87
	<i>Motor-Free Visual Perception Test (MVPT - Colarusso &amp; Hammill, 2003)</i> – A flip book style multiple-choice standardized measure of general spatial ability that includes mental rotation items, embedded figures items, items that require the detection of small differences in stimuli, etc. 65 item maximum raw score.	15	Reported – $\alpha$ > .80 for all ages over 7; test-retest for ages 11-84 = .92  Observed – $\alpha$ = .68***
Verbal Ability	<i>Vocabulary Test (Spelling)</i> – The vocabulary subscale of the Woodcock-Johnson III (Woodcock, Mather, & McGrew, 2001) was used as a measure of verbal ability (for discriminant validity, in comparison to spatial measures). Participants spelled a word given to them verbally with an accompanying sentence using the word. 59 item maximum raw score.	10	Reported – split-half reliability from .89-.95 for ages 18-39  Observed – $\alpha$ = .71***
Demo-graphic Information	<i>Information Questionnaire</i> – Collected demographic information for sample description and to control for socio-economic variables that may be related to outcomes. 14 items.	5	N/A

APPENDIX C CONTINUED

Post-Test	<i>Post-Test Battery</i> - All pre-test measures (except the information questionnaire) were re-administered to allow assessment of learning across the training period.	120	N/A
Exit Surveys	<i>General Exit Survey</i> - 9 questions that pertained to the general game playing experience for people in both the Portal and ES conditions. The mean of 7 of these questions were combined into a scale to measure the participants' enjoyment of the game.	5	Observed – $\alpha = .74$ ( $N = 40$ )
	<i>Elder Scrolls Exit Survey</i> - A 19-item Likert-scale and open-ended questionnaire about experiences with the game. 8 of these items were combined into a scale to measure participant judgments about how useful the map was for playing the game.	5	Observed – $\alpha = .89$ ( $N = 20$ )
	<i>Portal Exit Survey</i> - A 16-item Likert-scale and open-ended questionnaire about experiences with the game that were specific to Portal. No scale was created from these questions.	5	N/A
Training Fidelity	<i>Journal</i> - Participants were asked to keep a study journal documenting the date, time, and length of their play sessions as well as game specific information related to their progress and/or use of the map. <i>Save Game Files</i> - Participants were asked to continuously save new versions of their save files to keep a chronological record of their play time and to prove progress through the game. <i>Exit Surveys</i> - Also used to help ensure fidelity in the event either a journal or save file was not returned.	N/A	N/A

$\alpha$  = Chronbach's alpha; calculated using T1 data (N=78 unless noted otherwise)

\* Observed reliability refers to the reliability values calculated from the current data set. Reported reliabilities are reliabilities that have been reported in the literature (where available).

\*\*Alpha calculated from Log10 transformation of error scores because alpha cannot be calculated from the correlations used for distance estimates (calculating the correlations collapses across trials).

\*\*\*9 items from both the MVPT and Spelling Tests had 0 variance and had to be dropped; the alpha statistic is probably deflated as a result; this sample likely does not contain a full range of ability when compared to the standardization samples used for these tests.

## APPENDIX D

### CONFLICT OF INTEREST STATEMENT

The game disks for this study were purchased at retail without the knowledge of Bethesda Softworks LLC or Valve Corporation. Due to the use of the software distribution platform *Steam* to validate and update copies of the game *Portal*, I did contact Valve Corporation about the study so that I could be allowed to open multiple accounts (one for each copy) using a single name and e-mail address. Their system normally blocks individuals from having multiple accounts and they were helpful in relaxing this restriction at my request. However, at no point did any company fund any part of this project, nor have I received any personal income associated with the actual or expected outcomes of this research.

## REFERENCES

- Bakker, N.H., Werkhoven, P.J., & Passenier, P.O. (1999). The effects of proprioceptive and visual feedback on geographical orientation in virtual environments. *Presence*, 8(1), 36-53.
- Barnett, S.M., & Ceci, S.J. (2002). When and where do we apply what we learn? A taxonomy for far transfer. *Psychological Bulletin*, 128(4), 612-637.
- Brady Games. (2005). *World of Warcraft Atlas*. Indianapolis, IN: Author.
- Borkowf, C.B. (2002). Computing the non-null asymptotic variance and the asymptotic relative efficiency of Spearman's rank correlation. *Computational Statistics and Data Analysis*, 39, 271-286.
- Brooks, F.P. (1999). What's real about virtual reality? *IEEE Computer Graphics and Applications*, 19(6), 16-27.
- Burnett, G. E., & Lee, K. (2005). The effect of vehicle navigation systems on the formation of cognitive maps. In G. Underwood (Ed.), *Traffic and transportation psychology: Theory and application* (pp. 407-418). Amsterdam: Elsevier.
- Carnagey, N.L. & Anderson, C.A. (2005). The effects of reward and punishment in violent video games on aggressive affect, cognition, and behavior. *Psychological Science*, 16(11), 882-889.
- Castel, A.D., Pratt, J., & Drummond, E. (2005). The effects of action video game experience on the time course of inhibition of return and efficiency of visual search. *Acta Psychologica*, 119, 217-230.
- Colarusso, R.P., & Hammill, D.D. (2003) *Motor-free visual perception test third edition*. Novato, California: Academic Therapy Publications.
- Costello, A.B. & Osborne, J.W. (2005). Best practices in exploratory factor analysis: Four recommendations for getting the most from your analysis. *Practical Assessment, Research, and Evaluation*, 10, 1-9.
- Dammit (Artist). (2008). Diagram showing retention of speed but change of direction in the video game *Portal*. Retrieved from [http://en.wikipedia.org/wiki/File:Portal\\_physics-2.svg](http://en.wikipedia.org/wiki/File:Portal_physics-2.svg)
- Deloitte (2010). State of the media democracy [online]. Retrieved from [http://www.deloitte.com/view/en\\_US/us/press/Press-Releases/dce196d6a8295210VgnVCM100000ba42f00aRCRD.htm](http://www.deloitte.com/view/en_US/us/press/Press-Releases/dce196d6a8295210VgnVCM100000ba42f00aRCRD.htm) (October 10, 2010)

- Downs, R.J., & Stea, D., (1973). Cognitive maps and spatial behavior. In R.J. Downs & D. Stea (Eds.), *Image and environment: Cognitive mapping and spatial behavior* (pp. 8-26). Chicago, IL: Aldine Publishing Company.
- ESRI Inc. (2009). ArcGIS version 9 [computer software]. Available from <http://www.esri.com/>
- Fabrigar, L.R., Wegner, D.T., MacCallum, R.C., & Strahan, E.J. (1999). Evaluating the use of exploratory factor analysis in psychological research. *Psychological Methods*, 4(3), 272-299.
- Feng, J., Spence, S., & Pratt, J. (2007). Playing an action video game reduces gender differences in spatial cognition. *Psychological Science*, 18(10), 850-855.
- Green, C.S. & Bavelier, D. (2003). Action video game modifies visual selective attention. *Nature*, 423, 534-537.
- Hegarty, M., Richardson, A.E., Montello, D.R., Lovelace, K., & Subbiah, I. (2002). Development of a self-report measure of environmental spatial ability. *Intelligence*, 30, 425-447.
- Hegarty, M. & Waller, D.A. (2006). Individual differences in spatial ability. In P. Shah & A. Miyake (Eds.), *The Cambridge handbook of visuospatial thinking* (pp. 121-169). Cambridge, UK: Cambridge University Press.
- Hegarty, M., Montello, D.R., Richardson, A.E., Ishikawa, T., and Lovelace, K. (2006). Spatial abilities at different scales: Individual differences in aptitude-test performance and spatial-layout learning, *Intelligence*, 34, 151-176.
- Levine, M., Marchon, I., and Hanley, G. (1984). The Placement and Misplacement of You-Are-Here Maps, *Environment and Behavior*, 16, 139-157.
- Liben, L.S., Kastens, K.A., & Stevenson, L.M. (2002). Real-world knowledge through real-world maps: A developmental guide for navigating the educational terrain. *Developmental Review*, 22, 267-322.
- Linn, M.C. & Petersen, A.C. (1985). Emergence and characterization of sex differences in spatial ability: A meta-analysis. *Child Development*, 56 (6), 1479-1498.
- Loomis, J.M., Da Silva, J.A., Fujita, N., & Fukusima, S.S. (1992). Visual space perception and visually directed action. *Journal of Experimental Psychology: Human Perception and Performance*, 18(4), 906-921.
- Loomis, J.M., Klatzky, R.L., Golledge, R.G., & Philbeck, J.W. (1999). Human navigation by path integration. In R.G. Golledge (Ed.), *Wayfinding behavior: Cognitive mapping and other spatial processes* (pp. 125-151). Baltimore, MD: Johns Hopkins University Press.

- Montello, D.R., Lovelace, K.L., Golledge, R.G., & Self, C.M. (1999). Sex-related differences and similarities in geographic and environmental spatial abilities. *Annals of the Association of American Geographers*, 89(3), 515-534.
- Munroe, R.L. & Monroe, R.H. (1971). Effect of environmental experience on spatial ability in an East African society. *Journal of Social Psychology*, 83, 15-22.
- Murphy, K. & Spencer, A. (2009). Playing video games does not make for better visual attention skills. *Journal of Articles in Support of the Null Hypothesis*, 6(1), 1-20.
- National Oceanic and Atmospheric Administration (2011). Estimated Value of Magnetic Declination. Retrieved from <http://www.ngdc.noaa.gov/geomagmodels/struts/calcDeclination>.
- Nerlove, S.B., Munroe, R.H., & Munroe, R.L. (1971). Effect of environmental experience on spatial ability: A replication. *Journal of Social Psychology*, 84, 3-10.
- Nori, R., Grandicelli, S., & Giusberti, F. (2009). Individual differences in spatial working memory and real-world wayfinding. *Swiss Journal of Psychology*, 68(1), 7-16.
- Oliver, K.J., & Burnett, G.E. (2008). Learning-oriented vehicle navigation systems: A preliminary investigation in a driving simulator. *Proceedings of the 10<sup>th</sup> International Conference on Human-Computer Interaction with Mobile Devices and Services*, 119-126.
- Parush, A. & Berman, D. (2004). Navigation and orientation in 3D user interfaces: the impact of navigation aids and landmarks. *International Journal of Human-Computer Studies*, 61, 375-395.
- Péruch, P., Belingard, L., Thinus-Blanc, C. (2000). Transfer of spatial knowledge from virtual to real environments. In C. Freksa, W. Brauer, C. Habel, & K. Wender (Eds.), *Lecture notes in computer science* (pp. 253-264). Heidelberg: Springer Berlin.
- Peponis, J., Zimring, C. & Choi, Y. K. (1990). Finding the building in wayfinding. *Environment and Behaviour*, 22(5), 555-590.
- Pew Internet (2008). Pew internet and American life project: Adults and video games. Available: <http://www.pewinternet.org/Reports/2008/Adults-and-Video-Games.aspx>. (October 10, 2010).
- Presson, C.C., and Hazelrigg, M.D., (1984). Building spatial representations through primary and secondary learning. *Journal of Experimental Psychology: Learning, Memory and Cognition*, 10, 716-222.
- Rieser, J.J. (1989). Access to knowledge of spatial structure at novel points of observation. *Journal of Experimental Psychology: Learning, Memory, and Cognition*, 15(6), 1157-1165.



- Rieser, J.J., Pick, H.L., Ashmead, D.H., & Garing, A.E. (1995). Calibration of human locomotion and models of perceptual-motor organization. *Journal of Experimental Psychology: Human Perception and Performance*, 21(3), 480-497.
- Ruddle, R.A., & Lessels, S. (2006). For efficient navigational search, humans require full physical movement, but not a rich visual scene. *Psychological Science*, 17(6), 460-465.
- Shantz, C.U. & Watson, J.S. (1971). Spatial abilities and spatial egocentrism in the young child. *Child Development*, 42, 171-181.
- Shepard, R.N., & Metzler, J. (1971). Mental rotation of three dimensional objects. *Science*, 171(972), 701-703.
- Subrahmanyam, K. & Greenfield, P.M. (1994). Effect of video game practice on spatial skills in girls and boys. *Journal of Applied Developmental Psychology*, 15(1), 13-32.
- Subrahmanyam, K., Kraut, R.E., Greenfield, P.M., & Gross, E.F. (2000). The impact of home computer use on children's activities and development. *The Future of Children*, 10(2), 144.
- Thorndyke, P.W. & Hayes-Roth, B. (1982). Differences in spatial knowledge acquired from maps and navigation. *Cognitive Psychology*, 14, 560-589.
- Vandewater, E.A., Shim, M., & Caplovitz, A.G. (2004). Linking obesity and activity level with children's television and video game use. *Journal of Adolescence*, 27, 71-85.
- Waller, D. Hunt, E., & Knapp, D. (1998). The transfer of spatial knowledge in virtual environment training. *Presence*, 7(2), 129-143.
- Wikipedia.com. (2007). *Video game genres*. Retrieved December 3, 2007. Web site: [http://en.wikipedia.org/wiki/Video\\_game\\_genres](http://en.wikipedia.org/wiki/Video_game_genres).
- Wilson, P.N., Foreman, N., & Tlauka, M. (1997). Transfer of spatial information from a virtual to real environment. *Human Factors*, 39(4), 526-532.
- Witmer, B.G., Bailey, J.H., & Knerr, B.W. (1996). Virtual spaces and real world places: Transfer of route knowledge. *International Journal of Human and Computer Studies*, 45, 413-428.
- Woodcock, R.W., Mather, N., McGrew, K.S. (2001). *Woodcock-Johnson III Tests of Cognitive Abilities Examiner's Manual*. Itasca: Riverside.